

SPECIAL REPORT

Relativity in Combinatorial Gravitational Fields

Linfan Mao

Chinese Academy of Mathematics and System Science,
Beijing 100080, P. R. China
E-mail: maolinfan@163.com

A combinatorial spacetime $(\mathcal{C}_G|\vec{t})$ is a smoothly combinatorial manifold \mathcal{C} underlying a graph G evolving on a time vector \vec{t} . As we know, Einstein's general relativity is suitable for use only in one spacetime. *What is its disguise in a combinatorial spacetime?* Applying combinatorial Riemannian geometry enables us to present a combinatorial spacetime model for the Universe and suggest a generalized Einstein gravitational equation in such model. For finding its solutions, a generalized relativity principle, called *projective principle* is proposed, i.e., *a physics law in a combinatorial spacetime is invariant under a projection on its a subspace* and then a spherically symmetric multi-solutions of generalized Einstein gravitational equations in vacuum or charged body are found. We also consider the geometrical structure in such solutions with physical formations, and conclude that an ultimate theory for the Universe maybe established if all such spacetimes in \mathbf{R}^3 . Otherwise, our theory is only an approximate theory and endless forever.

1 Combinatorial spacetimes

The multi-laterality of our Universe implies the best spacetime model should be a combinatorial one. However, classical spacetimes are all in solitude. For example, the Newton spacetime $(\mathbf{R}^3|t)$ is a geometrical space $(x_1, x_2, x_3) \in \mathbf{R}^3$ with an absolute time $t \in \mathbf{R}^+$. With his deep insight in physical laws, Einstein was aware of that all reference frames were established by human beings, which made him realized that *a physics law is invariant in any reference frame*. Whence, the Einstein spacetime is $(\mathbf{R}^3|t) \cong \mathbf{R}^4$ with $t \in \mathbf{R}^+$, i.e., a warped spacetime generating gravitation. In this kind of spacetime, its line element is

$$ds^2 = \sum_{0 \leq \mu, \nu \leq 3} g_{\mu\nu}(\bar{x}) dx_\mu dx_\nu,$$

where $g_{\mu\nu}$, $0 \leq \mu, \nu \leq 3$ are Riemannian metrics with local flat, i.e., the Minkowskian spacetime

$$ds^2 = -c^2 dt^2 + dx_1^2 + dx_2^2 + dx_3^2,$$

where c is the light speed. *Wether the spacetime of Universe is isolated?* In fact, there are no justifications for Newton's or Einstein's choice but only dependent on mankind's perception with the geometry of visible, i.e., the spherical geometry(see [1–4] for details).

Certainly, different standpoints had unilaterally brought about particular behaviors of the Universe such as those of electricity, magnetism, thermal, optics... in physics and their combinations, for example, the thermodynamics, electromagnetism, ..., etc. But the true colours of the Universe should be hybrid, not homogeneous or unilateral. They should be a union or a combination of all these features underlying a combinatorial structure. That is the origin of combinatorial

spacetime established on smoothly combinatorial manifolds following ([5–9]), a particular case of Smarandache multi-space ([10–11]) underlying a connected graph.

Definition 1.1 *Let $n_i, 1 \leq i \leq m$ be positive integers. A combinatorial Euclidean space is a combinatorial system \mathcal{C}_G of Euclidean spaces $\mathbf{R}^{n_1}, \mathbf{R}^{n_2}, \dots, \mathbf{R}^{n_m}$ underlying a connected graph G defined by*

$$V(G) = \{\mathbf{R}^{n_1}, \mathbf{R}^{n_2}, \dots, \mathbf{R}^{n_m}\},$$

$$E(G) = \{(\mathbf{R}^{n_i}, \mathbf{R}^{n_j}) \mid \mathbf{R}^{n_i} \cap \mathbf{R}^{n_j} \neq \emptyset, 1 \leq i, j \leq m\},$$

denoted by $\mathcal{E}_G(n_1, \dots, n_m)$ and abbreviated to $\mathcal{E}_G(r)$ if $n_1 = \dots = n_m = r$.

A combinatorial fan-space $\widetilde{\mathbf{R}}(n_1, \dots, n_m)$ is a combinatorial Euclidean space $\mathcal{E}_{K_m}(n_1, \dots, n_m)$ of $\mathbf{R}^{n_1}, \mathbf{R}^{n_2}, \dots, \mathbf{R}^{n_m}$ such that for any integers $i, j, 1 \leq i \neq j \leq m, \mathbf{R}^{n_i} \cap \mathbf{R}^{n_j} = \bigcap_{k=1}^m \mathbf{R}^{n_k}$,

which is in fact a p -brane with $p = \dim \bigcap_{k=1}^m \mathbf{R}^{n_k}$ in string theory ([12]), seeing Fig. 1.1 for details.

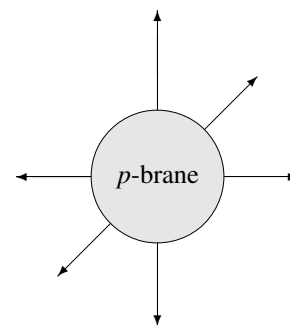

Fig. 1.1

For $\forall p \in \widetilde{\mathbf{R}}(n_1, \dots, n_m)$ we can present it by an $m \times m$ coordinate matrix $[\bar{x}]$ following with $x_{il} = \frac{x_l}{m}$ for $1 \leq i \leq m, 1 \leq l \leq \widehat{m}$,

$$[\bar{x}] = \begin{bmatrix} x_{11} & \cdots & x_{1\widehat{m}} & \cdots & x_{1n_1} & \cdots & 0 \\ x_{21} & \cdots & x_{2\widehat{m}} & \cdots & x_{2n_2} & \cdots & 0 \\ \cdots & \cdots & \cdots & \cdots & \cdots & \cdots & \cdots \\ x_{m1} & \cdots & x_{m\widehat{m}} & \cdots & \cdots & \cdots & x_{mn_m} \end{bmatrix}.$$

A topological combinatorial manifold \widetilde{M} is defined in the next.

Definition 1.2 For a given integer sequence $0 < n_1 < n_2 < \dots < n_m, m \geq 1$, a topological combinatorial manifold \widetilde{M} is a Hausdorff space such that for any point $p \in \widetilde{M}$, there is a local chart (U_p, φ_p) of p , i.e., an open neighborhood U_p of p in \widetilde{M} and a homeomorphism $\varphi_p : U_p \rightarrow \widetilde{\mathbf{R}}(n_1(p), \dots, n_{s(p)}(p))$ with

$$\begin{aligned} \{n_1(p), \dots, n_{s(p)}(p)\} &\subseteq \{n_1, \dots, n_m\}, \\ \bigcup_{p \in \widetilde{M}} \{n_1(p), \dots, n_{s(p)}(p)\} &= \{n_1, \dots, n_m\}, \end{aligned}$$

denoted by $\widetilde{M}(n_1, n_2, \dots, n_m)$ or \widetilde{M} on the context and

$$\widetilde{\mathcal{A}} = \{(U_p, \varphi_p) | p \in \widetilde{M}(n_1, n_2, \dots, n_m)\}$$

an atlas on $\widetilde{M}(n_1, n_2, \dots, n_m)$.

A topological combinatorial manifold \widetilde{M} is finite if it is just combined by finite manifolds without one manifold contained in the union of others.

For a finite combinatorial manifold \widetilde{M} consisting of manifolds $M_i, 1 \leq i \leq m$, we can construct a vertex-edge labeled graph $G^L[\widetilde{M}]$ defined by

$$\begin{aligned} V(G^L[\widetilde{M}]) &= \{M_1, M_2, \dots, M_m\}, \\ E(G^L[\widetilde{M}]) &= \{(M_i, M_j) | M_i \cap M_j \neq \emptyset, 1 \leq i, j \leq m\} \end{aligned}$$

with a labeling mapping

$$\Theta : V(G^L[\widetilde{M}]) \cup E(G^L[\widetilde{M}]) \rightarrow \mathbf{Z}^+$$

determined by

$$\Theta(M_i) = \dim M_i, \quad \Theta(M_i, M_j) = \dim M_i \cap M_j$$

for integers $1 \leq i, j \leq m$, which is inherent structure of combinatorial manifolds. A differentiable combinatorial manifold is defined by endowing differential structure on a topological combinatorial manifold following.

Definition 1.3 For a given integer sequence $1 \leq n_1 < n_2 < \dots < n_m$, a combinatorial C^h -differential manifold $(\widetilde{M}(n_1, n_2, \dots, n_m); \widetilde{\mathcal{A}})$ is a finite combinatorial manifold $\widetilde{M}(n_1, \dots, n_m)$,

$\widetilde{M}(n_1, \dots, n_m) = \bigcup_{i \in I} U_i$, endowed with an atlas $\widetilde{\mathcal{A}} = \{(U_\alpha; \varphi_\alpha) | \alpha \in I\}$ on $\widetilde{M}(n_1, \dots, n_m)$ for an integer $h, h \geq 1$ with conditions following hold.

- (1) $\{U_\alpha; \alpha \in I\}$ is an open covering of $\widetilde{M}(n_1, n_2, \dots, n_m)$.
- (2) For $\forall \alpha, \beta \in I$, local charts $(U_\alpha; \varphi_\alpha)$ and $(U_\beta; \varphi_\beta)$ are equivalent, i.e., $U_\alpha \cap U_\beta = \emptyset$ or $U_\alpha \cap U_\beta \neq \emptyset$ but the overlap maps

$$\begin{aligned} \varphi_\alpha \varphi_\beta^{-1} &: \varphi_\beta(U_\alpha \cap U_\beta) \rightarrow \varphi_\alpha(U_\alpha), \\ \varphi_\beta \varphi_\alpha^{-1} &: \varphi_\alpha(U_\alpha \cap U_\beta) \rightarrow \varphi_\beta(U_\beta) \end{aligned}$$

both are C^h -mappings, such as those shown in Fig. 1.2 following.

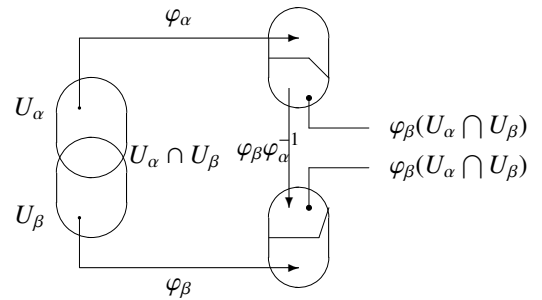

Fig. 1.2

- (3) $\widetilde{\mathcal{A}}$ is maximal, i.e., if $(U; \varphi)$ is a local chart of $\widetilde{M}(n_1, \dots, n_m)$ equivalent with one of local charts in $\widetilde{\mathcal{A}}$, then $(U; \varphi) \in \widetilde{\mathcal{A}}$.

A finite combinatorial manifold $\widetilde{M}(n_1, \dots, n_m)$ is smooth if it is endowed with a C^∞ -differential structure. Now we are in the place introducing combinatorial spacetime.

Definition 1.4 A combinatorial spacetime $(\mathcal{C}_G | \bar{t})$ is a smooth combinatorial manifold \mathcal{C} underlying a graph G evolving on a time vector \bar{t} , i.e., a geometrical space \mathcal{C} with a time system \bar{t} such that $(\bar{x} | \bar{t})$ is a particle's position at a time \bar{t} for $\bar{x} \in \mathcal{C}$.

The existence of combinatorial spacetime in the Universe is a wide-ranging, even if in the society science. By the explaining in the reference [13], there are four-level hierarchy of parallel universes analyzed by knowledge of mankind already known, such as those of *Hubble volumes*, *chaotic inflation*, *wavefunction* and *mathematical equations*, etc. Each level is allowed progressively greater diversity.

Question 1.5 How to deal behaviors of these different combinatorial spacetimes definitely with mathematics, not only qualitatively?

Recently, many researchers work for brane-world cosmology, particular for the case of dimensional ≤ 6 , such as those researches in references [14–18] and [3] etc. This brane-world model was also applied in [19] for explaining a black hole model for the Universe by combination. Notice that the

underlying combinatorial structure of brane-world cosmological model is essentially a tree for simplicity.

Now we have established a differential geometry on combinatorial manifolds in references [5–9], which provides us with a mathematical tool for determining the behavior of combinatorial spacetimes. The main purpose of this paper is to apply it to combinatorial gravitational fields combining with spacetime’s characters, present a generalized relativity in combinatorial fields and use this principle to solve the gravitational field equations. We also discuss the consistency of this combinatorial model for the Universe with some observing data such as the cosmic microwave background (CMB) radiation by WMAP in 2003.

2 Curvature tensor on combinatorial manifolds

Applying combinatorial spacetimes to that of gravitational field needs us to introduce curvature tensor for measuring the warping of combinatorial manifolds. In this section, we explain conceptions with results appeared in references [5–8], which are applied in this paper.

First, the structure of tangent and cotangent spaces $T_p\tilde{M}$, $T_p^*\tilde{M}$ at any point $p \in \tilde{M}$ in a smoothly combinatorial manifold \tilde{M} is similar to that of differentiable manifold. It has been shown in [5] that $\dim T_p\tilde{M}(n_1, \dots, n_m) = \widehat{s}(p) + \sum_{i=1}^{s(p)} (n_i - \widehat{s}(p))$ and $\dim T_p^*\tilde{M}(n_1, n_2, \dots, n_m) = \widehat{s}(p) + \sum_{i=1}^{s(p)} (n_i - \widehat{s}(p))$ with a basis

$$\left\{ \frac{\partial}{\partial x^{i_0 j}} \Big|_p \mid 1 \leq j \leq \widehat{s}(p) \right\} \cup \left(\bigcup_{i=1}^{s(p)} \left\{ \frac{\partial}{\partial x^{i j}} \Big|_p \mid \widehat{s}(p) + 1 \leq j \leq n_i \right\} \right),$$

$$\left\{ dx^{i_0 j} \Big|_p \mid 1 \leq j \leq \widehat{s}(p) \right\} \cup \left(\bigcup_{i=1}^{s(p)} \left\{ dx^{i j} \Big|_p \mid \widehat{s}(p) + 1 \leq j \leq n_i \right\} \right)$$

for any integer $i_0, 1 \leq i_0 \leq s(p)$, respectively. These mathematical structures enable us to construct tensors, connections on tensors and curvature tensors on smoothly combinatorial manifolds.

Definition 2.1 Let \tilde{M} be a smoothly combinatorial manifold, $p \in \tilde{M}$. A tensor of type (r, s) at the point p on \tilde{M} is an $(r + s)$ -multilinear function τ ,

$$\tau : \underbrace{T_p^*\tilde{M} \times \dots \times T_p^*\tilde{M}}_r \times \underbrace{T_p\tilde{M} \times \dots \times T_p\tilde{M}}_s \rightarrow \mathbf{R}.$$

Let $\tilde{M}(n_1, \dots, n_m)$ be a smoothly combinatorial manifold. Denoted by $T_s^r(p, \tilde{M})$ all tensors of type (r, s) at a point p of $\tilde{M}(n_1, \dots, n_m)$. Then for $\forall p \in \tilde{M}(n_1, \dots, n_m)$, we have known that

$$T_s^r(p, \tilde{M}) = \underbrace{T_p\tilde{M} \otimes \dots \otimes T_p\tilde{M}}_r \otimes \underbrace{T_p^*\tilde{M} \otimes \dots \otimes T_p^*\tilde{M}}_s,$$

where

$$T_p\tilde{M} = T_p\tilde{M}(n_1, \dots, n_m),$$

$$T_p^*\tilde{M} = T_p^*\tilde{M}(n_1, \dots, n_m),$$

particularly,

$$\dim T_s^r(p, \tilde{M}) = \left(\widehat{s}(p) + \sum_{i=1}^{s(p)} (n_i - \widehat{s}(p)) \right)^{r+s}$$

by argumentation in [5–7].

A connection on tensors of a smooth combinatorial manifold is defined by

Definition 2.2 Let \tilde{M} be a smooth combinatorial manifold. A connection on tensors of \tilde{M} is a mapping $\tilde{D} : \mathcal{X}(\tilde{M}) \times T_s^r\tilde{M} \rightarrow T_s^r\tilde{M}$ with $\tilde{D}_X\tau = \tilde{D}(X, \tau)$ such that for $\forall X, Y \in \mathcal{X}\tilde{M}$, $\tau, \pi \in T_s^r(\tilde{M})$, $\lambda \in \mathbf{R}$ and $f \in C^\infty(\tilde{M})$,

- (1) $\tilde{D}_{X+fY}\tau = \tilde{D}_X\tau + f\tilde{D}_Y\tau$ and $\tilde{D}_X(\tau + \lambda\pi) = \tilde{D}_X\tau + \lambda\tilde{D}_X\pi$;
- (2) $\tilde{D}_X(\tau \otimes \pi) = \tilde{D}_X\tau \otimes \pi + \tau \otimes \tilde{D}_X\pi$;
- (3) for any contraction C on $T_s^r(\tilde{M})$,

$$\tilde{D}_X(C(\tau)) = C(\tilde{D}_X\tau).$$

For a smooth combinatorial manifold \tilde{M} , we have shown in [5] that there always exists a connection \tilde{D} on \tilde{M} with coefficients $\Gamma_{(\sigma\varsigma)(\mu\nu)}^{\kappa\lambda}$ determined by

$$\tilde{D}_{\frac{\partial}{\partial x^{\mu\nu}}} \frac{\partial}{\partial x^{\sigma\varsigma}} = \Gamma_{(\sigma\varsigma)(\mu\nu)}^{\kappa\lambda} \frac{\partial}{\partial x^{\sigma\varsigma}}.$$

A combinatorially connection space (\tilde{M}, \tilde{D}) is a smooth combinatorial manifold \tilde{M} with a connection \tilde{D} .

Definition 2.3 Let \tilde{M} be a smoothly combinatorial manifold and $g \in A^2(\tilde{M}) = \bigcup_{p \in \tilde{M}} T_2^0(p, \tilde{M})$. If g is symmetrical and positive,

then \tilde{M} is called a combinatorially Riemannian manifold, denoted by (\tilde{M}, g) . In this case, if there is also a connection \tilde{D} on (\tilde{M}, g) with equality following hold

$$Z(g(X, Y)) = g(\tilde{D}_Z, Y) + g(X, \tilde{D}_Z Y),$$

then \tilde{M} is called a combinatorially Riemannian geometry, denoted by $(\tilde{M}, g, \tilde{D})$.

It has been proved in [5] and [7] that there exists a unique connection \tilde{D} on (\tilde{M}, g) such that $(\tilde{M}, g, \tilde{D})$ is a combinatorially Riemannian geometry.

Definition 2.4 Let (\tilde{M}, \tilde{D}) be a combinatorially connection space. For $\forall X, Y \in \mathcal{X}(\tilde{M})$, a combinatorially curvature operator $\tilde{R}(X, Y) : \mathcal{X}(\tilde{M}) \rightarrow \mathcal{X}(\tilde{M})$ is defined by

$$\tilde{R}(X, Y)Z = \tilde{D}_X\tilde{D}_Y Z - \tilde{D}_Y\tilde{D}_X Z - \tilde{D}_{[X, Y]}Z$$

for $\forall Z \in \mathcal{X}(\tilde{M})$.

Definition 2.5 Let (\tilde{M}, \tilde{D}) be a combinatorially connection space. For $\forall X, Y, Z \in \mathcal{X}(\tilde{M})$, a linear multi-mapping $\tilde{\mathcal{R}} : \mathcal{X}(\tilde{M}) \times \mathcal{X}(\tilde{M}) \times \mathcal{X}(\tilde{M}) \rightarrow \mathcal{X}(\tilde{M})$ determined by

$$\tilde{\mathcal{R}}(Z, X, Y) = \tilde{\mathcal{R}}(X, Y)Z$$

is said a curvature tensor of type (1, 3) on (\tilde{M}, \tilde{D}) .

Calculation in [7] shows that for $\forall p \in \tilde{M}$ with a local chart $(U_p; [\varphi_p])$,

$$\tilde{\mathcal{R}} = \tilde{\mathcal{R}}_{(\sigma\zeta)(\mu\nu)(\kappa\lambda)}^{\eta\theta} dx^{\sigma\zeta} \otimes \frac{\partial}{\partial x^{\eta\theta}} \otimes dx^{\mu\nu} \otimes dx^{\kappa\lambda}$$

with

$$\tilde{\mathcal{R}}_{(\sigma\zeta)(\mu\nu)(\kappa\lambda)}^{\eta\theta} = \left(\frac{\partial \Gamma_{(\sigma\zeta)(\kappa\lambda)}^{\eta\theta}}{\partial x^{\mu\nu}} - \frac{\partial \Gamma_{(\sigma\zeta)(\mu\nu)}^{\eta\theta}}{\partial x^{\kappa\lambda}} + \Gamma_{(\sigma\zeta)(\kappa\lambda)}^{\theta\iota} \Gamma_{(\theta\iota)(\mu\nu)}^{\eta\theta} - \Gamma_{(\sigma\zeta)(\mu\nu)}^{\theta\iota} \Gamma_{(\theta\iota)(\kappa\lambda)}^{\eta\theta} \right) \frac{\partial}{\partial x^{\theta\iota}},$$

where $\Gamma_{(\mu\nu)(\kappa\lambda)}^{\sigma\zeta} \in C^\infty(U_p)$ is determined by

$$\tilde{D}_{\frac{\partial}{\partial x^{\mu\nu}}} \frac{\partial}{\partial x^{\kappa\lambda}} = \Gamma_{(\kappa\lambda)(\mu\nu)}^{\sigma\zeta} \frac{\partial}{\partial x^{\sigma\zeta}}.$$

Particularly, if $(\tilde{M}, g, \tilde{D})$ is a combinatorially Riemannian geometry, we know the combinatorially Riemannian curvature tensor in the following.

Definition 2.6 Let $(\tilde{M}, g, \tilde{D})$ be a combinatorially Riemannian manifold. A combinatorially Riemannian curvature tensor $\tilde{R} : \mathcal{X}(\tilde{M}) \times \mathcal{X}(\tilde{M}) \times \mathcal{X}(\tilde{M}) \times \mathcal{X}(\tilde{M}) \rightarrow C^\infty(\tilde{M})$ of type (0, 4) is defined by

$$\tilde{R}(X, Y, Z, W) = g(\tilde{R}(Z, W)X, Y)$$

for $\forall X, Y, Z, W \in \mathcal{X}(\tilde{M})$.

Now let $(\tilde{M}, g, \tilde{D})$ be a combinatorially Riemannian manifold. For $\forall p \in \tilde{M}$ with a local chart $(U_p; [\varphi_p])$, we have known that ([8])

$$\tilde{R} = \tilde{R}_{(\sigma\zeta)(\eta\theta)(\mu\nu)(\kappa\lambda)} dx^{\sigma\zeta} \otimes dx^{\eta\theta} \otimes dx^{\mu\nu} \otimes dx^{\kappa\lambda}$$

with

$$\begin{aligned} \tilde{R}_{(\sigma\zeta)(\eta\theta)(\mu\nu)(\kappa\lambda)} &= \frac{1}{2} \left(\frac{\partial^2 g_{(\mu\nu)(\sigma\zeta)}}{\partial x^{\kappa\lambda} \partial x^{\eta\theta}} + \frac{\partial^2 g_{(\kappa\lambda)(\eta\theta)}}{\partial x^{\mu\nu} \partial x^{\sigma\zeta}} - \frac{\partial^2 g_{(\mu\nu)(\eta\theta)}}{\partial x^{\kappa\lambda} \partial x^{\sigma\zeta}} - \frac{\partial^2 g_{(\kappa\lambda)(\sigma\zeta)}}{\partial x^{\mu\nu} \partial x^{\eta\theta}} \right) + \Gamma_{(\mu\nu)(\sigma\zeta)}^{\theta\iota} \Gamma_{(\kappa\lambda)(\eta\theta)}^{\xi\sigma} g_{(\xi\sigma)(\theta\iota)} - \\ &- \Gamma_{(\mu\nu)(\eta\theta)}^{\xi\sigma} \Gamma_{(\kappa\lambda)(\sigma\zeta)}^{\theta\iota} g_{(\xi\sigma)(\theta\iota)}, \end{aligned}$$

where $g_{(\mu\nu)(\kappa\lambda)} = g \left(\frac{\partial}{\partial x^{\mu\nu}}, \frac{\partial}{\partial x^{\kappa\lambda}} \right)$.

Application of these mechanisms in Definitions 2.1–2.6 with results obtained in references [5–9], [20–23] enables us to find physical laws in combinatorial spacetimes by mathematical equations, and then find their multi-solutions in following sections.

3 Combinatorial gravitational fields

3.1 Gravitational equations

The essence in Einstein's notion on the gravitational field is known in two principles following.

Principle 3.1 These gravitational forces and inertial forces acting on a particle in a gravitational field are equivalent and indistinguishable from each other.

Principle 3.2 An equation describing a law of physics should have the same form in all reference frame.

By Principle 3.1, one can introduce inertial coordinate system in Einstein's spacetime which enables it flat locally, i.e., transfer these Riemannian metrics to Minkowskian ones and eliminate the gravitational forces locally. Principle 3.2 means that a physical equation should be a tensor equation. But *how about the combinatorial gravitational field?* We assume Principles 3.1 and 3.2 hold in this case, i.e., a physical law is characterized by a tensor equation. This assumption enables us to deduce the gravitational field equation following.

Let $\mathcal{L}_{G^L[\tilde{M}]}$ be the Lagrange density of a combinatorial spacetime $(\mathcal{C}_G|\tilde{t})$. Then we know equations of the combinatorial gravitational field $(\mathcal{C}_G|\tilde{t})$ to be

$$\partial_\mu \frac{\partial \mathcal{L}_{G^L[\tilde{M}]}}{\partial \partial_\mu \phi_{\tilde{M}}} - \frac{\partial \mathcal{L}_{G^L[\tilde{M}]}}{\partial \phi_{\tilde{M}}} = 0, \quad (3.1)$$

by the Euler-Lagrange equation, where $\phi_{\tilde{M}}$ is the wave function of $(\mathcal{C}_G|\tilde{t})$. Choose its Lagrange density $\mathcal{L}_{G^L[\tilde{M}]}$ to be

$$\mathcal{L}_{G^L[\tilde{M}]} = \tilde{R} - 2\kappa \mathcal{L}_F,$$

where $\kappa = -8\pi G$ and \mathcal{L}_F the Lagrange density for all other fields with

$$\tilde{R} = g^{(\mu\nu)(\kappa\lambda)} \tilde{R}_{(\mu\nu)(\kappa\lambda)}, \quad \tilde{R}_{(\mu\nu)(\kappa\lambda)} = \tilde{R}_{(\mu\nu)(\sigma\zeta)(\kappa\lambda)}^{\sigma\zeta}.$$

Applying the Euler-Lagrange equation we get the equation of combinatorial gravitational field following

$$\tilde{\mathcal{R}}_{(\mu\nu)(\kappa\lambda)} - \frac{1}{2} \tilde{R} g_{(\mu\nu)(\kappa\lambda)} = \kappa \mathcal{E}_{(\mu\nu)(\kappa\lambda)}, \quad (3.2)$$

where $\mathcal{E}_{(\mu\nu)(\kappa\lambda)}$ is the energy-momentum tensor.

The situation for combinatorial gravitational field is a little different from classical field by its combinatorial character with that one can only determines unilateral or part behaviors of the field. We generalize the Einstein notion to combinatorial gravitational field by the following projective principle, which is coordinated with one's observation.

Principle 3.3 A physics law in a combinatorial field is invariant under a projection on its a field.

By Principles 3.1 and 3.2 with combinatorial differential geometry shown in Section 2, Principle 3.3 can be rephrased as follows.

Projective principle Let $(\widetilde{M}, g, \widetilde{D})$ be a combinatorial Riemannian manifold and $\mathcal{F} \in T_s^r(\widetilde{M})$ with a local form

$$\mathcal{F}_{(\mu_1\nu_1)\dots(\mu_s\nu_s)}^{(\kappa_1\lambda_1)\dots(\kappa_r\lambda_r)} e_{\kappa_1\lambda_1} \otimes \dots \otimes e_{\kappa_r\lambda_r} \omega^{\mu_1\nu_1} \otimes \dots \otimes \omega^{\mu_s\nu_s}$$

in $(U_p, [\varphi_p])$. If

$$\mathcal{F}_{(\mu_1\nu_1)\dots(\mu_s\nu_s)}^{(\kappa_1\lambda_1)\dots(\kappa_r\lambda_r)} = 0$$

for integers $1 \leq \mu_i \leq s(p)$, $1 \leq \nu_i \leq n_{\mu_i}$ with $1 \leq i \leq s$ and $1 \leq \kappa_j \leq s(p)$, $1 \leq \lambda_j \leq n_{\kappa_j}$ with $1 \leq j \leq r$, then for any integer μ , $1 \leq \mu \leq s(p)$, there must be

$$\mathcal{F}_{(\mu\nu_1)\dots(\mu\nu_s)}^{(\mu\lambda_1)\dots(\mu\lambda_s)} = 0$$

for integers ν_i , $1 \leq \nu_i \leq n_{\mu}$ with $1 \leq i \leq s$.

Certainly, we can only determine the behavior of space which we live. Then *what is about these other spaces in $(\mathcal{C}_G|\bar{t})$?* Applying the projective principle, we can simulate each of them by that of our living space. In other words, combining geometrical structures already known to a combinatorial one $(\mathcal{C}_G|\bar{t})$ and then find its solution for equation (3.2).

3.2 Combinatorial metric

Let $\widetilde{\mathcal{A}}$ be an atlas on $(\widetilde{M}, g, \widetilde{D})$. Choose a local chart $(U; \varpi)$ in $\widetilde{\mathcal{A}}$. By definition, if $\varphi_p : U_p \rightarrow \bigcup_{i=1}^{s(p)} B^{n_i(p)}$ and $\widehat{s}(p) = \dim(\bigcap_{i=1}^{s(p)} B^{n_i(p)})$, then $[\varphi_p]$ is an $s(p) \times n_{s(p)}$ matrix. A *combinatorial metric* is defined by

$$ds^2 = g_{(\mu\nu)(\kappa\lambda)} dx^{\mu\nu} dx^{\kappa\lambda}, \quad (3.3)$$

where $g_{(\mu\nu)(\kappa\lambda)}$ is the Riemannian metric in the combinatorially Riemannian manifold $(\widetilde{M}, g, \widetilde{D})$. Generally, we choose a orthogonal basis

$$\{\bar{e}_{11}, \dots, \bar{e}_{1n_1}, \dots, \bar{e}_{s(p)n_{s(p)}}\}$$

for $\varphi_p[U]$, $p \in \widetilde{M}(t)$, i.e., $\langle \bar{e}_{\mu\nu}, \bar{e}_{\kappa\lambda} \rangle = \delta_{(\mu\nu)}^{(\kappa\lambda)}$. Then the formula (3.3) turns to

$$\begin{aligned} ds^2 &= g_{(\mu\nu)(\mu\nu)} (dx^{\mu\nu})^2 \\ &= \sum_{\mu=1}^{s(p)} \sum_{\nu=1}^{\widehat{s}(p)} g_{(\mu\nu)(\mu\nu)} (dx^{\mu\nu})^2 + \\ &\quad + \sum_{\mu=1}^{s(p)} \sum_{\nu=1}^{\widehat{s}(p)+1} g_{(\mu\nu)(\mu\nu)} (dx^{\mu\nu})^2 \\ &= \frac{1}{s^2(p)} \sum_{\nu=1}^{\widehat{s}(p)} \left(\sum_{\mu=1}^{s(p)} g_{(\mu\nu)(\mu\nu)} \right) dx^\nu + \\ &\quad + \sum_{\mu=1}^{s(p)} \sum_{\nu=1}^{\widehat{s}(p)+1} g_{(\mu\nu)(\mu\nu)} (dx^{\mu\nu})^2. \end{aligned}$$

We therefore find an important relation of combinatorial metric with that of its projections following.

Theorem 3.1 Let ${}_\mu ds^2$ be the metric in a manifold $\phi_p^{-1}(B^{n_\mu(p)})$ for integers $1 \leq \mu \leq s(p)$. Then

$$ds^2 = {}_1 ds^2 + {}_2 ds^2 + \dots + {}_{s(p)} ds^2.$$

Proof Applying the projective principle, we immediately know that

$${}_\mu ds^2 = ds^2|_{\phi_p^{-1}(B^{n_\mu(p)})}, \quad 1 \leq \mu \leq s(p).$$

Whence, we find that

$$\begin{aligned} ds^2 &= g_{(\mu\nu)(\mu\nu)} (dx^{\mu\nu})^2 \\ &= \sum_{\mu=1}^{s(p)} \sum_{\nu=1}^{n_i(p)} g_{(\mu\nu)(\mu\nu)} (dx^{\mu\nu})^2 \\ &= \sum_{\mu=1}^{s(p)} ds^2|_{\phi_p^{-1}(B^{n_\mu(p)})} = \sum_{\mu=1}^{s(p)} {}_\mu ds^2. \end{aligned}$$

□

This relation enables us to find the line element of combinatorial gravitational field $(\mathcal{C}_G|\bar{t})$ by applying that of gravitational fields.

3.3 Combinatorial Schwarzschild metric

Let $(\mathcal{C}_G|\bar{t})$ be a gravitational field. We know its Schwarzschild metric, i.e., a spherically symmetric solution of Einstein's gravitational equations in vacuum is

$$ds^2 = \left(1 - \frac{r_s}{r}\right) dt^2 - \frac{dr^2}{1 - \frac{r_s}{r}} - r^2 d\theta^2 - r^2 \sin^2 \theta d\phi^2, \quad (3.4)$$

where $r_s = 2Gm/c^2$. Now we generalize it to combinatorial gravitational fields to find the solutions of equations

$$R_{(\mu\nu)(\sigma\tau)} - \frac{1}{2} g_{(\mu\nu)(\sigma\tau)} R = -8\pi G \mathcal{E}_{(\mu\nu)(\sigma\tau)}$$

in vacuum, i.e., $\mathcal{E}_{(\mu\nu)(\sigma\tau)} = 0$. Notice that the underlying graph of combinatorial field consisting of m gravitational fields is a complete graph K_m . For such a objective, we only consider the homogeneous combinatorial Euclidean spaces $\widetilde{M} = \bigcup_{i=1}^m \mathbf{R}^{n_i}$, i.e., for any point $p \in \widetilde{M}$,

$$[\varphi_p] = \begin{bmatrix} x^{11} & \dots & x^{1n_1} & \dots & 0 \\ x^{21} & \dots & x^{2n_2} & \dots & 0 \\ \dots & \dots & \dots & \dots & \dots \\ x^{m1} & \dots & \dots & \dots & x^{mn_m} \end{bmatrix}$$

with $\widehat{m} = \dim(\bigcap_{i=1}^m \mathbf{R}^{n_i})$ a constant for $\forall p \in \bigcap_{i=1}^m \mathbf{R}^{n_i}$ and $x^{il} = \frac{x^l}{m}$ for $1 \leq i \leq m$, $1 \leq l \leq \widehat{m}$.

Let $(\mathcal{C}_G|\bar{t})$ be a combinatorial field of gravitational fields M_1, \dots, M_m with masses m_1, \dots, m_m respectively. For usually undergoing, we consider the case of $n_\mu = 4$ for $1 \leq \mu \leq m$ since line elements have been found concretely in classical gravitational field in these cases. Now establish m spherical coordinate subframe $(t_\mu; r_\mu, \theta_\mu, \phi_\mu)$ with its originality at the center of such a mass space. Then we have known its a spherically symmetric solution by (3.4) to be

$$ds_\mu^2 = \left(1 - \frac{r_{\mu s}}{r_\mu}\right) dt_\mu^2 - \left(1 - \frac{r_{\mu s}}{r_\mu}\right)^{-1} dr_\mu^2 - r_\mu^2 (d\theta_\mu^2 + \sin^2 \theta_\mu d\phi_\mu^2)$$

for $1 \leq \mu \leq m$ with $r_{\mu s} = 2Gm_\mu/c^2$. By Theorem 3.1, we know that

$$ds^2 = {}_1ds^2 + {}_2ds^2 + \dots + {}_m ds^2,$$

where ${}_\mu ds^2 = ds_\mu^2$ by the projective principle on combinatorial fields. Notice that $1 \leq \widehat{m} \leq 4$. We therefore get the geometrical of $(\mathcal{C}_G|\bar{t})$ dependent on \widehat{m} following.

Case 1. $\widehat{m} = 1$, i.e., $t_\mu = t$ for $1 \leq \mu \leq m$.

In this case, the combinatorial metric ds is

$$ds^2 = \sum_{\mu=1}^m \left(1 - \frac{2Gm_\mu}{c^2 r_\mu}\right) dt^2 - \sum_{\mu=1}^m \left(1 - \frac{2Gm_\mu}{c^2 r_\mu}\right)^{-1} dr_\mu^2 - \sum_{\mu=1}^m r_\mu^2 (d\theta_\mu^2 + \sin^2 \theta_\mu d\phi_\mu^2).$$

Case 2. $\widehat{m} = 2$, i.e., $t_\mu = t$ and $r_\mu = r$, or $t_\mu = t$ and $\theta_\mu = \theta$, or $t_\mu = t$ and $\phi_\mu = \phi$ for $1 \leq \mu \leq m$.

We consider the following subcases.

Subcase 2.1. $t_\mu = t, r_\mu = r$.

In this subcase, the combinatorial metric is

$$ds^2 = \sum_{\mu=1}^m \left(1 - \frac{2Gm_\mu}{c^2 r}\right) dt^2 - \left(\sum_{\mu=1}^m \left(1 - \frac{2Gm_\mu}{c^2 r}\right)^{-1}\right) dr^2 - \sum_{\mu=1}^m r^2 (d\theta_\mu^2 + \sin^2 \theta_\mu d\phi_\mu^2),$$

which can only happens if these m fields are at a same point O in a space. Particularly, if $m_\mu = M$ for $1 \leq \mu \leq m$, the

masses of M_1, M_2, \dots, M_m are the same, then $r_{\mu g} = 2GM$ is a constant, which enables us knowing that

$$ds^2 = \left(1 - \frac{2GM}{c^2 r}\right) m dt^2 - \left(1 - \frac{2GM}{c^2 r}\right)^{-1} m dr^2 - \sum_{\mu=1}^m r^2 (d\theta_\mu^2 + \sin^2 \theta_\mu d\phi_\mu^2).$$

Subcase 2.2. $t_\mu = t, \theta_\mu = \theta$.

In this subcase, the combinatorial metric is

$$ds^2 = \sum_{\mu=1}^m \left(1 - \frac{2Gm_\mu}{c^2 r_\mu}\right) dt^2 - \sum_{\mu=1}^m \left(1 - \frac{2Gm_\mu}{c^2 r_\mu}\right)^{-1} dr_\mu^2 - \sum_{\mu=1}^m r_\mu^2 (d\theta^2 + \sin^2 \theta d\phi_\mu^2).$$

Subcase 2.3. $t_\mu = t, \phi_\mu = \phi$.

In this subcase, the combinatorial metric is

$$ds^2 = \sum_{\mu=1}^m \left(1 - \frac{2Gm_\mu}{c^2 r_\mu}\right) dt^2 - \left(\sum_{\mu=1}^m \left(1 - \frac{2Gm_\mu}{c^2 r_\mu}\right)^{-1}\right) dr_\mu^2 - \sum_{\mu=1}^m r_\mu^2 (d\theta_\mu^2 + \sin^2 \theta_\mu d\phi^2).$$

Case 3. $\widehat{m} = 3$, i.e., $t_\mu = t, r_\mu = r$ and $\theta_\mu = \theta$, or $t_\mu = t, r_\mu = r$ and $\phi_\mu = \phi$, or $t_\mu = t, \theta_\mu = \theta$ and $\phi_\mu = \phi$ for $1 \leq \mu \leq m$.

We consider three subcases following.

Subcase 3.1. $t_\mu = t, r_\mu = r$ and $\theta_\mu = \theta$.

In this subcase, the combinatorial metric is

$$ds^2 = \sum_{\mu=1}^m \left(1 - \frac{2Gm_\mu}{c^2 r}\right) dt^2 - \left(\sum_{\mu=1}^m \left(1 - \frac{2Gm_\mu}{c^2 r}\right)^{-1}\right) dr^2 - mr^2 d\theta^2 - r^2 \sin^2 \theta \sum_{\mu=1}^m d\phi_\mu^2.$$

Subcase 3.2. $t_\mu = t, r_\mu = r$ and $\phi_\mu = \phi$.

In this subcase, the combinatorial metric is

$$ds^2 = \sum_{\mu=1}^m \left(1 - \frac{2Gm_\mu}{c^2 r}\right) dt^2 - \sum_{\mu=1}^m \left(1 - \frac{2Gm_\mu}{c^2 r}\right)^{-1} dr^2 - r^2 \sum_{\mu=1}^m (d\theta_\mu^2 + \sin^2 \theta_\mu d\phi_\mu^2).$$

There subcases 3.1 and 3.2 can be only happen if the centers of these m fields are at a same point O in a space.

Subcase 3.3. $t_\mu = t, \theta_\mu = \theta$ and $\phi_\mu = \phi$.

In this subcase, the combinatorial metric is

$$ds^2 = \sum_{\mu=1}^m \left(1 - \frac{2Gm_\mu}{c^2 r_\mu}\right) dt^2 - \sum_{\mu=1}^m \left(1 - \frac{2Gm_\mu}{c^2 r_\mu}\right)^{-1} dr_\mu^2 - \sum_{\mu=1}^m r_\mu (d\theta^2 + \sin^2 \theta d\phi^2).$$

Case 4. $\widehat{m} = 4$, i.e., $t_\mu = t, r_\mu = r, \theta_\mu = \theta$ and $\phi_\mu = \phi$ for $1 \leq \mu \leq m$.

In this subcase, the combinatorial metric is

$$ds^2 = \sum_{\mu=1}^m \left(1 - \frac{2Gm_\mu}{c^2 r}\right) dt^2 - \sum_{\mu=1}^m \left(1 - \frac{2Gm_\mu}{c^2 r}\right)^{-1} dr^2 - mr^2 (d\theta^2 + \sin^2 \theta d\phi^2).$$

Particularly, if $m_\mu = M$ for $1 \leq \mu \leq m$, we get that

$$ds^2 = \left(1 - \frac{2GM}{c^2 r}\right) m dt^2 - \left(1 - \frac{2GM}{c^2 r}\right)^{-1} m dr^2 - mr^2 (d\theta^2 + \sin^2 \theta d\phi^2).$$

Define a coordinate transformation

$$(t, r, \theta, \phi) \rightarrow ({}_s t, {}_s r, {}_s \theta, {}_s \phi) = (t \sqrt{m}, r \sqrt{m}, \theta, \phi).$$

Then the previous formula turns to

$$ds^2 = \left(1 - \frac{2GM}{c^2 r}\right) d_s t^2 - \frac{d_s r^2}{1 - \frac{2GM}{c^2 r}} - {}_s r^2 (d_s \theta^2 + \sin^2 {}_s \theta d_s \phi^2)$$

in this new coordinate system $({}_s t, {}_s r, {}_s \theta, {}_s \phi)$, whose geometrical behavior likes that of the gravitational field.

3.4 Combinatorial Reissner-Nordström metric

The Schwarzschild metric is a spherically symmetric solution of the Einstein gravitational equations in conditions $\mathcal{E}_{(\mu\nu)(\sigma\tau)} = 0$. In some special cases, we can also find their solutions for the case $\mathcal{E}_{(\mu\nu)(\sigma\tau)} \neq 0$. The *Reissner-Nordström metric* is such a case with

$$\mathcal{E}_{(\mu\nu)(\sigma\tau)} = \frac{1}{4\pi} \left(\frac{1}{4} g_{\mu\nu} F_{\alpha\beta} F^{\alpha\beta} - F_{\mu\alpha} F_\nu^\alpha \right)$$

in the Maxwell field with total mass m and total charge e , where $F_{\alpha\beta}$ and $F^{\alpha\beta}$ are given in Subsection 7.3.4. Its metrics takes the following form:

$$g_{\mu\nu} = \begin{bmatrix} x_{11} & 0 & 0 & 0 \\ 0 & x_{22} & 0 & 0 \\ 0 & 0 & -r^2 & 0 \\ 0 & 0 & 0 & -r^2 \sin^2 \theta \end{bmatrix},$$

where $r_s = 2Gm/c^2, r_e^2 = 4G\pi e^2/c^4, x_{11} = 1 - \frac{r_s}{r} + \frac{r_e^2}{r^2}$ and $x_{22} = -\left(1 - \frac{r_s}{r} + \frac{r_e^2}{r^2}\right)^{-1}$. In this case, its line element ds is given by

$$ds^2 = \left(1 - \frac{r_s}{r} + \frac{r_e^2}{r^2}\right) dt^2 - \left(1 - \frac{r_s}{r} + \frac{r_e^2}{r^2}\right)^{-1} dr^2 - r^2 (d\theta^2 + \sin^2 \theta d\phi^2). \tag{3.5}$$

Obviously, if $e = 0$, i.e., there are no charges in the gravitational field, then the equations (3.5) turns to that of the Schwarzschild metric (3.4).

Now let $(\mathcal{G}_G|\widehat{\Gamma})$ be a combinatorial field of charged gravitational fields M_1, M_2, \dots, M_m with masses m_1, m_2, \dots, m_m and charges e_1, e_2, \dots, e_m , respectively. Similar to the case of Schwarzschild metric, we consider the case of $n_\mu = 4$ for $1 \leq \mu \leq m$. We establish m spherical coordinate subframe $(t_\mu; r_\mu, \theta_\mu, \phi_\mu)$ with its originality at the center of such a mass space. Then we know its a spherically symmetric solution by (3.5) to be

$$ds_\mu^2 = \left(1 - \frac{r_{\mu s}}{r_\mu} + \frac{r_{\mu e}^2}{r_\mu^2}\right) dt_\mu^2 - \left(1 - \frac{r_{\mu s}}{r_\mu} + \frac{r_{\mu e}^2}{r_\mu^2}\right)^{-1} dr_\mu^2 - r_\mu^2 (d\theta_\mu^2 + \sin^2 \theta_\mu d\phi_\mu^2).$$

Likewise the case of Schwarzschild metric, we consider combinatorial fields of charged gravitational fields dependent on the intersection dimension \widehat{m} following.

Case 1. $\widehat{m} = 1$, i.e., $t_\mu = t$ for $1 \leq \mu \leq m$.

In this case, by applying Theorem 3.1 we get the combinatorial metric

$$ds^2 = \sum_{\mu=1}^m \left(1 - \frac{r_{\mu s}}{r_\mu} + \frac{r_{\mu e}^2}{r_\mu^2} \right) dt^2 - \sum_{\mu=1}^m \left(1 - \frac{r_{\mu s}}{r_\mu} + \frac{r_{\mu e}^2}{r_\mu^2} \right)^{-1} dr_\mu^2 - \sum_{\mu=1}^m r_\mu^2 (d\theta_\mu^2 + \sin^2 \theta_\mu d\phi_\mu^2).$$

Case 2. $\widehat{m} = 2$, i.e., $t_\mu = t$ and $r_\mu = r$, or $t_\mu = t$ and $\theta_\mu = \theta$, or $t_\mu = t$ and $\phi_\mu = \phi$ for $1 \leq \mu \leq m$.

Consider the following three subcases.

Subcase 2.1. $t_\mu = t$, $r_\mu = r$.

In this subcase, the combinatorial metric is

$$ds^2 = \sum_{\mu=1}^m \left(1 - \frac{r_{\mu s}}{r} + \frac{r_{\mu e}^2}{r^2} \right) dt^2 - \sum_{\mu=1}^m \left(1 - \frac{r_{\mu s}}{r} + \frac{r_{\mu e}^2}{r^2} \right)^{-1} dr^2 - \sum_{\mu=1}^m r^2 (d\theta_\mu^2 + \sin^2 \theta_\mu d\phi_\mu^2),$$

which can only happens if these m fields are at a same point O in a space. Particularly, if $m_\mu = M$ and $e_\mu = e$ for $1 \leq \mu \leq m$, we find that

$$ds^2 = \left(1 - \frac{2GM}{c^2 r} + \frac{4\pi G e^4}{c^4 r^2} \right) m dt^2 - \frac{m dr^2}{1 - \frac{2GM}{c^2 r} + \frac{4\pi G e^4}{c^4 r^2}} - \sum_{\mu=1}^m r^2 (d\theta_\mu^2 + \sin^2 \theta_\mu d\phi_\mu^2).$$

Subcase 2.2. $t_\mu = t$, $\theta_\mu = \theta$.

In this subcase, by applying Theorem 3.1 we know that the combinatorial metric is

$$ds^2 = \sum_{\mu=1}^m \left(1 - \frac{r_{\mu s}}{r_\mu} + \frac{r_{\mu e}^2}{r_\mu^2} \right) dt^2 - \sum_{\mu=1}^m \left(1 - \frac{r_{\mu s}}{r_\mu} + \frac{r_{\mu e}^2}{r_\mu^2} \right)^{-1} dr_\mu^2 - \sum_{\mu=1}^m r_\mu^2 (d\theta^2 + \sin^2 \theta d\phi_\mu^2).$$

Subcase 2.3. $t_\mu = t$, $\phi_\mu = \phi$.

In this subcase, we know that the combinatorial metric is

$$ds^2 = \sum_{\mu=1}^m \left(1 - \frac{r_{\mu s}}{r_\mu} + \frac{r_{\mu e}^2}{r_\mu^2} \right) dt^2 - \sum_{\mu=1}^m \left(1 - \frac{r_{\mu s}}{r_\mu} + \frac{r_{\mu e}^2}{r_\mu^2} \right)^{-1} dr_\mu^2 - \sum_{\mu=1}^m r_\mu^2 (d\theta_\mu^2 + \sin^2 \theta_\mu d\phi^2).$$

Case 3. $\widehat{m} = 3$, i.e., $t_\mu = t$, $r_\mu = r$ and $\theta_\mu = \theta$, or $t_\mu = t$, $r_\mu = r$ and $\phi_\mu = \phi$, or $t_\mu = t$, $\theta_\mu = \theta$ and $\phi_\mu = \phi$ for $1 \leq \mu \leq m$.

We consider three subcases following.

Subcase 3.1. $t_\mu = t$, $r_\mu = r$ and $\theta_\mu = \theta$.

In this subcase, by applying Theorem 3.1 we obtain that the combinatorial metric is

$$ds^2 = \sum_{\mu=1}^m \left(1 - \frac{r_{\mu s}}{r} + \frac{r_{\mu e}^2}{r^2} \right) dt^2 - \sum_{\mu=1}^m \left(1 - \frac{r_{\mu s}}{r} + \frac{r_{\mu e}^2}{r^2} \right)^{-1} dr^2 - \sum_{\mu=1}^m r^2 (d\theta^2 + \sin^2 \theta d\phi_\mu^2).$$

Particularly, if $m_\mu = M$ and $e_\mu = e$ for $1 \leq \mu \leq m$, then we get that

$$ds^2 = \left(1 - \frac{2GM}{c^2 r} + \frac{4\pi G e^4}{c^4 r^2} \right) m dt^2 - \frac{m dr^2}{1 - \frac{2GM}{c^2 r} + \frac{4\pi G e^4}{c^4 r^2}} - \sum_{\mu=1}^m r^2 (d\theta^2 + \sin^2 \theta d\phi_\mu^2).$$

Subcase 3.2. $t_\mu = t$, $r_\mu = r$ and $\phi_\mu = \phi$.

In this subcase, the combinatorial metric is

$$ds^2 = \sum_{\mu=1}^m \left(1 - \frac{r_{\mu s}}{r} + \frac{r_{\mu e}^2}{r^2} \right) dt^2 - \sum_{\mu=1}^m \left(1 - \frac{r_{\mu s}}{r} + \frac{r_{\mu e}^2}{r^2} \right)^{-1} dr^2 - \sum_{\mu=1}^m r^2 (d\theta_\mu^2 + \sin^2 \theta_\mu d\phi^2).$$

Particularly, if $m_\mu = M$ and $e_\mu = e$ for $1 \leq \mu \leq m$, then we get that

$$ds^2 = \left(1 - \frac{2GM}{c^2 r} + \frac{4\pi G e^4}{c^4 r^2}\right) m dt^2 - \frac{m dr^2}{1 - \frac{2GM}{c^2 r} + \frac{4\pi G e^4}{c^4 r^2}} - \sum_{\mu=1}^m r^2 (d\theta_\mu^2 + \sin^2 \theta_\mu d\phi_\mu^2).$$

Subcase 3.3. $t_\mu = t, \theta_\mu = \theta$ and $\phi_\mu = \phi$.

In this subcase, the combinatorial metric is

$$ds^2 = \sum_{\mu=1}^m \left(1 - \frac{r_{\mu s}}{r_\mu} + \frac{r_{\mu e}^2}{r_\mu^2}\right) dt^2 - \sum_{\mu=1}^m \left(1 - \frac{r_{\mu s}}{r_\mu} + \frac{r_{\mu e}^2}{r_\mu^2}\right)^{-1} dr_\mu^2 - \sum_{\mu=1}^m r_\mu^2 (d\theta^2 + \sin^2 \theta d\phi^2).$$

Case 4. $\widehat{m} = 4$, i.e., $t_\mu = t, r_\mu = r, \theta_\mu = \theta$ and $\phi_\mu = \phi$ for $1 \leq \mu \leq m$.

In this subcase, the combinatorial metric is

$$ds^2 = \sum_{\mu=1}^m \left(1 - \frac{r_{\mu s}}{r} + \frac{r_{\mu e}^2}{r^2}\right) dt^2 - \sum_{\mu=1}^m \left(1 - \frac{r_{\mu s}}{r} + \frac{r_{\mu e}^2}{r^2}\right)^{-1} dr^2 - mr^2 (d\theta^2 + \sin^2 \theta d\phi^2).$$

Furthermore, if $m_\mu = M$ and $e_\mu = e$ for $1 \leq \mu \leq m$, we obtain that

$$ds^2 = \left(1 - \frac{2GM}{c^2 r} + \frac{4\pi G e^4}{c^4 r^2}\right) m dt^2 - \frac{m dr^2}{1 - \frac{2GM}{c^2 r} + \frac{4\pi G e^4}{c^4 r^2}} - mr^2 (d\theta^2 + \sin^2 \theta d\phi^2).$$

Similarly, we define the coordinate transformation

$$(t, r, \theta, \phi) \rightarrow ({}_s t, {}_s r, {}_s \theta, {}_s \phi) = (t \sqrt{m}, r \sqrt{m}, \theta, \phi).$$

Then the previous formula turns to

$$ds^2 = \left(1 - \frac{2GM}{c^2 r} + \frac{4\pi G e^4}{c^4 r^2}\right) d_s t^2 - \frac{d_s r^2}{1 - \frac{2GM}{c^2 r} + \frac{4\pi G e^4}{c^4 r^2}} - {}_s r^2 (d_s \theta^2 + \sin^2 {}_s \theta d_s \phi^2)$$

in this new coordinate system $({}_s t, {}_s r, {}_s \theta, {}_s \phi)$, whose geometrical behavior likes a charged gravitational field.

4 Multi-time system

A *multi-time system* is such a combinatorial field $(\mathcal{C}_G|\bar{t})$ consisting of fields M_1, M_2, \dots, M_m on reference frames

$$(t_1, r_1, \theta_1, \phi_1), \dots, (t_m, r_m, \theta_m, \phi_m)$$

and there are always exist two integers $\kappa, \lambda, 1 \leq \kappa \neq \lambda \leq m$ such that $t_\kappa \neq t_\lambda$. Notice that these combinatorial fields discussed in Section 3 are all with $t_\mu = t$ for $1 \leq \mu \leq m$, i.e., we can establish a time variable t for all fields in this combinatorial field. But if we can not determine all the behavior of living things in the Universe implied in the *weak anthropic principle*, we can not find such a time variable t for all fields. If so, we need a multi-time system for describing the Universe.

Among these multi-time systems, an interesting case appears in $\widehat{m} = 3, r_\mu = r, \theta_\mu = \theta, \phi_\mu = \phi$, i.e., beings live in the same dimensional 3 space, but with different notions on the time. Applying Theorem 3.1, we discuss the Schwarzschild and Reissner-Nordström metrics following.

4.1 Schwarzschild multi-time system

In this case, the combinatorial metric is

$$ds^2 = \sum_{\mu=1}^m \left(1 - \frac{2Gm_\mu}{c^2 r}\right) dt_\mu^2 - \sum_{\mu=1}^m \left(1 - \frac{2Gm_\mu}{c^2 r}\right)^{-1} dr^2 - mr^2 (d\theta^2 + \sin^2 \theta d\phi^2).$$

Applying the projective principle to this equation, we get metrics on gravitational fields M_1, M_2, \dots, M_m following:

$$ds_1^2 = \left(1 - \frac{2Gm_1}{c^2 r}\right) dt_1^2 - \left(1 - \frac{2Gm_1}{c^2 r}\right)^{-1} dr^2 - r^2 (d\theta^2 + \sin^2 \theta d\phi^2),$$

$$ds_2^2 = \left(1 - \frac{2Gm_2}{c^2 r}\right) dt_2^2 - \left(1 - \frac{2Gm_2}{c^2 r}\right)^{-1} dr^2 - r^2 (d\theta^2 + \sin^2 \theta d\phi^2),$$

..... ,

$$ds_m^2 = \left(1 - \frac{2Gm_m}{c^2 r}\right) dt_m^2 - \dots, \\ - \left(1 - \frac{2Gm_m}{c^2 r}\right)^{-1} dr^2 - \\ - r^2 (d\theta^2 + \sin^2 \theta d\phi^2).$$

Particularly, if $m_\mu = M$ for $1 \leq \mu \leq m$, we then get that

$$ds^2 = \left(1 - \frac{2GM}{c^2 r}\right) \sum_{\mu=1}^m dt_\mu^2 - \\ - \left(1 - \frac{2GM}{c^2 r}\right)^{-1} mdr^2 - \\ - mr^2 (d\theta^2 + \sin^2 \theta d\phi^2).$$

Its projection on the gravitational field M_μ is

$$ds_\mu^2 = \left(1 - \frac{2GM}{c^2 r}\right) dt_\mu^2 - \\ - \left(1 - \frac{2GM}{c^2 r}\right)^{-1} dr^2 - \\ - r^2 (d\theta^2 + \sin^2 \theta d\phi^2),$$

i.e., the Schwarzschild metric on M_μ , $1 \leq \mu \leq m$.

4.2 Reissner-Nordström multi-time system

In this case, the combinatorial metric is

$$ds^2 = \sum_{\mu=1}^m \left(1 - \frac{2Gm_\mu}{c^2 r} + \frac{4\pi G e_\mu^4}{c^4 r^2}\right) dt_\mu^2 - \\ - \sum_{\mu=1}^m \left(1 - \frac{2Gm_\mu}{c^2 r} + \frac{4\pi G e_\mu^4}{c^4 r^2}\right)^{-1} dr^2 - \\ - mr^2 (d\theta^2 + \sin^2 \theta d\phi^2).$$

Similarly, by the projective principle we obtain the metrics on charged gravitational fields M_1, M_2, \dots, M_m following

$$ds_1^2 = \left(1 - \frac{2Gm_1}{c^2 r} + \frac{4\pi G e_1^4}{c^4 r^2}\right) dt_1^2 - \\ - \left(1 - \frac{2Gm_1}{c^2 r} + \frac{4\pi G e_1^4}{c^4 r^2}\right)^{-1} dr^2 - \\ - r^2 (d\theta^2 + \sin^2 \theta d\phi^2),$$

$$ds_2^2 = \left(1 - \frac{2Gm_2}{c^2 r} + \frac{4\pi G e_2^4}{c^4 r^2}\right) dt_2^2 - \\ - \left(1 - \frac{2Gm_2}{c^2 r} + \frac{4\pi G e_2^4}{c^4 r^2}\right)^{-1} dr^2 - \\ - r^2 (d\theta^2 + \sin^2 \theta d\phi^2),$$

$$ds_m^2 = \left(1 - \frac{2Gm_m}{c^2 r} + \frac{4\pi G e_m^4}{c^4 r^2}\right) dt_m^2 - \\ - \left(1 - \frac{2Gm_m}{c^2 r} + \frac{4\pi G e_m^4}{c^4 r^2}\right)^{-1} dr^2 - \\ - r^2 (d\theta^2 + \sin^2 \theta d\phi^2).$$

Furthermore, if $m_\mu = M$ and $e_\mu = e$ for $1 \leq \mu \leq m$, we obtain that

$$ds^2 = \left(1 - \frac{2GM}{c^2 r} + \frac{4\pi G e^4}{c^4 r^2}\right) \sum_{\mu=1}^m dt^2 - \\ - \left(1 - \frac{2GM}{c^2 r} + \frac{4\pi G e^4}{c^4 r^2}\right)^{-1} mdr^2 - \\ - mr^2 (d\theta^2 + \sin^2 \theta d\phi^2).$$

Its projection on the charged gravitational field M_μ is

$$ds_\mu^2 = \left(1 - \frac{2GM}{c^2 r} + \frac{4\pi G e^4}{c^4 r^2}\right) dt_\mu^2 - \\ - \left(1 - \frac{2GM}{c^2 r} + \frac{4\pi G e^4}{c^4 r^2}\right)^{-1} dr^2 - \\ - r^2 (d\theta^2 + \sin^2 \theta d\phi^2),$$

i.e., the Reissner-Nordström metric on M_μ , $1 \leq \mu \leq m$.

As a by-product, these calculations and formulas mean that these beings with time notion different from that of human beings will recognize differently the structure of our universe if these beings are intellectual enough to do so.

5 Discussions

5.1 Geometrical structure

A simple calculation shows that the dimension of the combinatorial gravitational field ($\mathcal{C}|\bar{i}$) in Section 3 is

$$\dim(\mathcal{C}|\bar{i}) = 4m + (1 - m)\widehat{m}. \tag{5.1}$$

For example, $\dim(\mathcal{C}|\bar{i}) = 7, 10, 13, 16$ if $\widehat{m} = 1$ and $6, 8, 10$ if $\widehat{m} = 1$ for $m = 2, 3, 4$. In this subsection, we analyze these geometrical structures with metrics appeared in Section 3.

As we have said in Section 1, the visible geometry is the spherical geometry of dimensional 3. That is why the sky looks like a spherical surface. In this geometry, we can only see the images of bodies with $\dim \geq 3$ on our spherical surface (see [1-2] and [4] in details). But the situation is a little difference from that of the transferring information, which is transferred in all possible routes. In other words, a geometry of dimensional ≥ 1 . Therefore, not all information transferring can be seen by our eyes. But some of them can be felt by

our six organs with the help of apparatus if needed. For example, the *magnetism* or *electromagnetism* can be only detected by apparatus. These notions enable us to explain the geometrical structures in combinatorial gravitational fields, for example, the Schwarzschild or Reissner-Nordström metrics.

Case 1. $\widehat{m} = 4$.

In this case, by the formula (5.1) we get $\dim(\mathcal{C}|\widehat{\tau}) = 4$, i.e., all fields M_1, M_2, \dots, M_m are in \mathbf{R}^4 , which is the most enjoyed case by human beings. We have gotten the Schwarzschild metric

$$ds^2 = \sum_{\mu=1}^m \left(1 - \frac{2Gm_\mu}{c^2 r}\right) dt^2 - \sum_{\mu=1}^m \left(1 - \frac{2Gm_\mu}{c^2 r}\right)^{-1} dr^2 - mr^2(d\theta^2 + \sin^2 \theta d\phi^2)$$

or the Reissner-Nordström metric

$$ds^2 = \sum_{\mu=1}^m \left(1 - \frac{r_{\mu s}}{r} + \frac{r_{\mu e}^2}{r^2}\right) dt^2 - \frac{dr^2}{\sum_{\mu=1}^m \left(1 - \frac{r_{\mu s}}{r} + \frac{r_{\mu e}^2}{r^2}\right)} - mr^2(d\theta^2 + \sin^2 \theta d\phi^2)$$

for non-charged or charged combinatorial gravitational fields in vacuum in Sections 3. If it is so, the behavior of Universe can be realized finally by human beings. This also means that the discover of science will be ended, i.e., we can established the *Theory of Everything* finally for the Universe.

Case 2. $\widehat{m} \leq 3$.

If the Universe is so, then $\dim(\mathcal{C}|\widehat{\tau}) \geq 5$. In this case, we know the combinatorial Schwarzschild metrics and combinatorial Reissner-Nordström metrics in Section 3, for example, if $t_\mu = t$, $r_\mu = r$ and $\phi_\mu = \phi$, the combinatorial Schwarzschild metric is

$$ds^2 = \sum_{\mu=1}^m \left(1 - \frac{r_{\mu s}}{r}\right) dt^2 - \sum_{\mu=1}^m \frac{dr^2}{\left(1 - \frac{r_{\mu s}}{r}\right)} - \sum_{\mu=1}^m r^2(d\theta_\mu^2 + \sin^2 \theta_\mu d\phi_\mu^2)$$

and the combinatorial Reissner-Nordström metric is

$$ds^2 = \sum_{\mu=1}^m \left(1 - \frac{r_{\mu s}}{r} + \frac{r_{\mu e}^2}{r^2}\right) dt^2 - \sum_{\mu=1}^m \frac{dr^2}{\left(1 - \frac{r_{\mu s}}{r} + \frac{r_{\mu e}^2}{r^2}\right)}$$

$$- \sum_{\mu=1}^m r^2(d\theta_\mu^2 + \sin^2 \theta_\mu d\phi_\mu^2).$$

Particularly, if $m_\mu = M$ and $e_\mu = e$ for $1 \leq \mu \leq m$, then we get that

$$ds^2 = \left(1 - \frac{2GM}{c^2 r}\right) m dt^2 - \frac{m dr^2}{\left(1 - \frac{2GM}{c^2 r}\right)} - \sum_{\mu=1}^m r^2(d\theta_\mu^2 + \sin^2 \theta_\mu d\phi_\mu^2)$$

for combinatorial gravitational field and

$$ds^2 = \left(1 - \frac{2GM}{c^2 r} + \frac{4\pi G e^4}{c^4 r^2}\right) m dt^2 - \frac{m dr^2}{\left(1 - \frac{2GM}{c^2 r} + \frac{4\pi G e^4}{c^4 r^2}\right)} - \sum_{\mu=1}^m r^2(d\theta_\mu^2 + \sin^2 \theta_\mu d\phi_\mu^2)$$

for charged combinatorial gravitational field in vacuum. In this case, the observed interval in the field M_O where human beings live is

$$ds_O = a(t, r, \theta, \phi) dt^2 - b(t, r, \theta, \phi) dr^2 - c(t, r, \theta, \phi) d\theta^2 - d(t, r, \theta, \phi) d\phi^2.$$

How to we explain the differences $ds - ds_O$ in physics?

Notice that we can only observe the line element ds_O , a projection of ds on M_O . Whence, all contributions in $ds - ds_O$ come from the spatial direction not observable by human beings. In this case, we are difficult to determine the exact behavior. Furthermore, if $\widehat{m} \leq 3$ holds, because there are infinite combinations $(\mathcal{C}_G|\widehat{\tau})$ of existent fields underlying a connected graph G , we can not find an ultimate theory for the Universe, i.e., there are no a *Theory of Everything* for the Universe and the science established by ours is approximate, holds on conditions and the discover of science will be endless forever.

5.2 Physical formation

A generally accepted notion on the formation of Universe is the Big Bang theory ([24]), i.e., the origin of Universe is from an exploded at a singular point on its beginning. Notice that the geometry in the Big Bang theory is just a Euclidean \mathbf{R}^3 geometry, i.e., a visible geometry by human beings. Then *how is it came into being for a combinatorial spacetime? Weather it is contradicts to the experimental data?* We will explain these questions following.

Realization 5.1 Any combinatorial spacetime was formed by $|G|$ times Big Bang in an early space.

Certainly, if there is just one time Big Bang, then there exists one spacetime observed by us, not a multiple or combinatorial spacetime. But there are no arguments for this claim.

It is only an assumption on the origin of Universe. If it is not exploded in one time, but in $m \geq 2$ times in different spatial directions, *what will happens for the structure of spacetime?*

The process of Big Bang model can be applied for explaining the formation of combinatorial spacetimes. Assume the dimension of original space is bigger enough and there are m explosions for the origin of Universe. Then likewise the standard process of Big Bang, each time of Big Bang brought a spacetime. After the m Big Bangs, we finally get a multi-spacetime underlying a combinatorial structure, i.e., a combinatorial spacetime $(\mathcal{C}_G|\bar{I})$ with $|G| = m$, such as those shown in Fig. 5.1 for $G = C_4$ or K_3 .

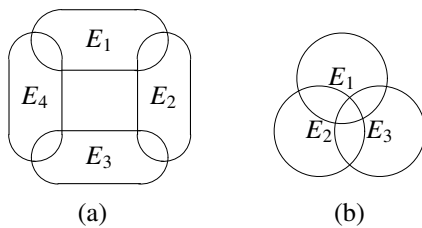

Fig. 5.1

where E_i denotes i^{th} time explosion for $1 \leq i \leq 4$. In the process of m Big Bangs, we do not assume that each explosion E_i , $1 \leq i \leq m$ was happened in a Euclidean space \mathbf{R}^3 , but in \mathbf{R}^n for $n \geq 3$. Whence, the intersection $E_i \cap E_j$ means the same spatial directions in explosions E_i and E_j for $1 \leq i, j \leq m$. Whence, information in E_i or E_j appeared along directions in $E_i \cap E_j$ will both be reflected in E_j or E_i . As we have said in Subsection 5.1, if $\dim E_i \cap E_j \leq 2$, then such information can not be seen by us but only can be detected by apparatus, such as those of the *magnetism* or *electromagnetism*.

Realization 5.2 *The spacetime lived by us is an intersection of other spacetimes.*

This fact is an immediately conclusion of Realization 5.1.

Realization 5.3 *Each experimental data on Universe obtained by human beings is synthesized, not be in one of its spacetimes.*

Today, we have known a few datum on the Universe by COBE or WMAP. In these data, the one well-known is the 2.7°K cosmic microwave background radiation. Generally, this data is thought to be an evidence of Big Bang theory. If the Universe is a combinatorial one, *how to we explain it?* First, the 2.7°K is not contributed by one Big Bang in \mathbf{R}^3 , but by many times before 137 light years, i.e., it is a synthesized data. Second, the 2.7°K is surveyed by WMAP, an explorer satellite in \mathbf{R}^3 . By the projective principle in Section 3, it is only a projection of the cosmic microwave background radiation in the Universe on the space \mathbf{R}^3 lived by us. In fact, all datum on the Universe surveyed by human beings can be explained in such a way. So there are no contradiction

between combinatorial model and datum on the Universe already known by us, but it reflects a combinatorial behavior of the Universe.

Submitted on February 22, 2010 / Accepted March 12, 2010

References

1. Belot G. Remarks on the geometry of visibles. *Philosophical Quarterly*, 2003, v. 53, 581–586.
2. Reid T. An inquiry into the human mind on the principles of common sense. In D. Brookes ed., Edinburgh University Press, 1997.
3. Shtanov Y.V. On brane-world cosmology. arXiv: hep-th/0005193.
4. Yaffe G. Reconsidering Reid's geometry of visibles. *Philosophical Quarterly*, 2002, v. 52, 602–620.
5. Mao L.F. Geometrical theory on combinatorial manifolds. *JP J. Geometry and Topology*, 2007, v. 7, no. 1, 65–114.
6. Mao L.F. An introduction to Smarandache multi-spaces and mathematical combinatorics. *Scientia Magna*, 2007, v. 3, no.1, 54–80.
7. Mao L.F. Curvature equations on combinatorial manifolds with applications to theoretical physics. *International J. Mathematical Combinatorics*, 2008, v. 1, 1–25.
8. Mao L.F. Combinatorially Riemannian submanifolds. *International J. Mathematical Combinatorics*, 2008, v. 2, 1–25.
9. Mao L.F. Combinatorial fields—an introduction. *International J. Mathematical Combinatorics*, 2009, v. 3, 1–22.
10. Rabounski D. Smarandache spaces as a new extension of the basic space-time of general relativity. *Progress in Physics*, 2010, v. 2, L1–L2.
11. Smarandache F. Mixed noneuclidean geometries. arXiv: math/0010119.
12. Moorw G.W. What is a brane? *Notices of the AMS*, 2005, v. 52, no. 2, 214–215.
13. Tegmark M. Parallel universes. In J.D. Barrow, P.C.W. Davies and C.L. Harper eds., *Science and Ultimate Reality: From Quantum to Cosmos*, Cambridge University Press, 2003.
14. Gunther U. and Zhuk A. Phenomenology of brane-world cosmological models. arXiv: gr-qc/0410130.
15. Ida D. Brane-world cosmology. arXiv: gr-qc/9912002.
16. Kanti P. Madden R. and Olive K.A. A 6-d brane world model. arXiv: hep-ph/0104177.
17. Papantonopoulos E. Braneworld cosmological models. arXiv: gr-qc/0410032.
18. Papantonopoulos E. Cosmology in six dimensions. arXiv: gr-qc/0601011.
19. Zhang T.X. A new cosmological model: black hole universe. *Progress in Physics*, 2009, v. 3, 3–11.
20. Mao L.F. Combinatorial geometry with applications to field theory. InfoQuest, USA, 2009.
21. Mao L.F. A combinatorial decomposition of Euclidean spaces \mathbf{R}^n with contribution to visibility. To be submitted to publication.
22. Mao L.F. Lie multi-groups underlying graphs. To be submitted to publication.
23. Mao L.F. Constructing principal fiber bundles by voltage assignment. To be submitted to publication.
24. Peacock J.A. *Cosmological physics*. Cambridge University Press, 1999.