

2012 Volume 2

**The Journal on Advanced Studies in Theoretical and Experimental Physics,
including Related Themes from Mathematics**

PROGRESS IN PHYSICS

**“All scientists shall have the right to present their scientific
research results, in whole or in part, at relevant scientific
conferences, and to publish the same in printed scientific
journals, electronic archives, and any other media.”
— Declaration of Academic Freedom, Article 8**

ISSN 1555-5534

PROGRESS IN PHYSICS

A quarterly issue scientific journal, registered with the Library of Congress (DC, USA). This journal is peer reviewed and included in the abstracting and indexing coverage of: Mathematical Reviews and MathSciNet (AMS, USA), DOAJ of Lund University (Sweden), Zentralblatt MATH (Germany), Scientific Commons of the University of St. Gallen (Switzerland), Open-J-Gate (India), Referativnyi Zhurnal VINITI (Russia), etc.

Electronic version of this journal:
<http://www.ptep-online.com>

Editorial Board

Dmitri Rabounski, Editor-in-Chief
rabounski@ptep-online.com
Florentin Smarandache, Assoc. Editor
smarand@unm.edu
Larissa Borissova, Assoc. Editor
borissova@ptep-online.com

Editorial Team

Gunn Quznetsov
quznetsov@ptep-online.com
Andreas Ries
ries@ptep-online.com
Chifu Ebenezer Ndikilar
ndikilar@ptep-online.com
Felix Scholkmann
scholkmann@ptep-online.com

Postal Address

Department of Mathematics and Science,
University of New Mexico,
705 Gurley Ave., Gallup, NM 87301, USA

Copyright © *Progress in Physics*, 2012

All rights reserved. The authors of the articles do hereby grant *Progress in Physics* non-exclusive, worldwide, royalty-free license to publish and distribute the articles in accordance with the Budapest Open Initiative: this means that electronic copying, distribution and printing of both full-size version of the journal and the individual papers published therein for non-commercial, academic or individual use can be made by any user without permission or charge. The authors of the articles published in *Progress in Physics* retain their rights to use this journal as a whole or any part of it in any other publications and in any way they see fit. Any part of *Progress in Physics* howsoever used in other publications must include an appropriate citation of this journal.

This journal is powered by L^AT_EX

A variety of books can be downloaded free from the Digital Library of Science:
<http://www.gallup.unm.edu/~smarandache>

ISSN: 1555-5534 (print)
ISSN: 1555-5615 (online)

Standard Address Number: 297-5092
Printed in the United States of America

APRIL 2012

VOLUME 2

CONTENTS

Ndikilar C. E. Relativistic Dynamical Theory for Test Particles and Photons in Static Spherically Symmetric Gravitational Fields	3
Zhang T. X. The Turning Point for the Recent Acceleration of the Universe with a Cosmological Constant	6
Ajaib M. A. Anisotropic to Isotropic Phase Transitions in the Early Universe	12
Assis A. V. D. B. Local Doppler Effect, Index of Refraction through the Earth Crust, PDF and the CNGS Neutrino Anomaly?	17
Lehnert B. A Way to Revised Quantum Electrodynamics	21
Smarandache F. Parameterized Special Theory of Relativity (PSTR)	28
Suhendro I. The Surjective Monad Theory of Reality: A Qualified Generalization of Reflexive Monism	30
Belyakov A. V. Macro-Analogies and Gravitation in the Micro-World: Further Elaboration of Wheeler's Model of Geometrodynamics	47
Tosto S. Quantum Uncertainty and Relativity	58
Carroll R. On a Fractional Quantum Potential	82
Ekuma C. E. and Chukwuocha E. O. A Model Third Order Phase Transition in Fe-Ni Pnictide Superconductors	87

LETTERS

Rabounski D. On the Exact Solution Explaining the Accelerate Expanding Universe According to General Relativity	L1
Kowalski L. Social Aspects of Cold Fusion: 23 Years Later	L7

Information for Authors and Subscribers

Progress in Physics has been created for publications on advanced studies in theoretical and experimental physics, including related themes from mathematics and astronomy. All submitted papers should be professional, in good English, containing a brief review of a problem and obtained results.

All submissions should be designed in L^AT_EX format using *Progress in Physics* template. This template can be downloaded from *Progress in Physics* home page <http://www.ptep-online.com>. Abstract and the necessary information about author(s) should be included into the papers. To submit a paper, mail the file(s) to the Editor-in-Chief.

All submitted papers should be as brief as possible. We accept brief papers, no larger than 8 typeset journal pages. Short articles are preferable. Large papers can be considered in exceptional cases to the section *Special Reports* intended for such publications in the journal. Letters related to the publications in the journal or to the events among the science community can be applied to the section *Letters to Progress in Physics*.

All that has been accepted for the online issue of *Progress in Physics* is printed in the paper version of the journal. To order printed issues, contact the Editors.

This journal is non-commercial, academic edition. It is printed from private donations. (Look for the current author fee in the online version of the journal.)

Relativistic Dynamical Theory for Test Particles and Photons in Static Spherically Symmetric Gravitational Fields

Chifu Ebenezer Ndikilar

Gombe State University, Faculty of Science, Physics Department, P.M.B. 127, Gombe, Gombe State, Nigeria
E-mail: ebenechifu@yahoo.com

The gravitational line element in this field is used to postulate the four spacetime element of arc vector, volume element, del operator and divergence operator for space-time gravitational fields. A relativistic dynamical theory is then established for static spherically symmetric gravitational fields. Equations of motion for test particles and photons are obtained with post Newton and post Einstein correction terms of all orders of c^{-2} .

1 Introduction

Schwarzschild in 1916 constructed the first exact solution of Einstein's gravitational field equations. It was the metric due to a static spherically symmetric body situated in empty space such as the Sun or a star [1].

In this article, we establish a link between Schwarzschild's metric and Newton's dynamical theory of gravitation. The consequence of this approach is the emergence of complete expressions for the velocity, acceleration and total energy with post Newton and post Einstein correction terms to all orders of c^{-2} [2].

2 Euclidean Geometry in Static Spherically Symmetric Fields

Recall that the scalar world line element dS^2 in Schwarzschild's gravitational field is given as

$$dS^2 = -g_{11}dr^2 - g_{22}d\theta^2 - g_{33}d\phi^2 + g_{00}(dx^0)^2 \quad (2.1)$$

where

$$g_{00} = \left(1 - \frac{2GM}{c^2 r}\right),$$

$$g_{11} = \left(1 - \frac{2GM}{c^2 r}\right)^{-1},$$

$$g_{22} = r^2,$$

$$g_{33} = r^2 \sin^2 \theta.$$

G is the universal gravitational constant, c is the speed of light in vacuum and M is the mass of the static homogeneous spherical mass (Schwarzschild's mass) [3, 4]. Now, also recall that the world line element dS^2 from which the metric tensor is formulated is obtained from the fundamental line element $d\bar{S}(r, \theta, \phi)$. Also, from vector analysis, it is well known that $d\bar{S}(r, \theta, \phi)$ is the most fundamental quantity from which all vector and scalar quantities required for the formulation of the dynamical theory of classical mechanics are derived.

2.1 Element of arc vector

From equation (2.1), we realise that Schwarzschild's gravitational field is a four dimensional orthogonal vector space with coordinates (r, θ, ϕ, x^0) and unit vectors $(\hat{r}, \hat{\theta}, \hat{\phi}, \hat{x}^0)$ and hence the element of arc vector $d\bar{S}$ is given as

$$d\bar{S} = [-g_{11}]^{1/2}(dr)\hat{r} + [-g_{22}]^{1/2}(d\theta)\hat{\theta} + [-g_{33}]^{1/2}(d\phi)\hat{\phi} + [g_{00}]^{1/2}(dx^0)\hat{x}^0 \quad (2.2)$$

with scale factors h_r, h_θ, h_ϕ and h_{x^0} defined as

$$h_r = [-g_{11}]^{1/2},$$

$$h_\theta = [-g_{22}]^{1/2},$$

$$h_\phi = [-g_{33}]^{1/2},$$

$$h_{x^0} = [g_{00}]^{1/2}.$$

2.2 Volume element and Gradient operators

As in Euclidean geometry in three dimensional vector space, we postulate that the volume element dV in Schwarzschild's gravitational field is given by

$$dV = dS_r dS_\theta dS_\phi dS_{x^0} \quad (2.3)$$

and the corresponding space element of volume

$$dV = dS_r dS_\theta dS_\phi, \quad (2.4)$$

where

$$dS_r = h_r dr,$$

$$dS_\theta = h_\theta d\theta,$$

$$dS_\phi = h_\phi d\phi,$$

$$dS_{x^0} = h_{x^0} dx^0.$$

We postulate that our complete spacetime del operator in Schwarzschild's gravitational field is given as

$$\bar{\nabla} = \frac{\hat{r}}{h_r} \frac{\partial}{\partial r} + \frac{\hat{\theta}}{h_\theta} \frac{\partial}{\partial \theta} + \frac{\hat{\phi}}{h_\phi} \frac{\partial}{\partial \phi} + \frac{\hat{x}^0}{h_{x^0}} \frac{\partial}{\partial x^0}. \quad (2.5)$$

The complete spacetime divergence, curl and laplacian operators can be defined in a similar manner[2].

3 Relativistic Dynamical Theory for Test Particles

From the spacetime line element, the instantaneous spacetime velocity vector in the gravitational field can be defined[2] as

$$\bar{u} = \frac{d\bar{S}}{d\tau} \quad (3.1)$$

or

$$\bar{u} = u_r \hat{r} + u_\theta \hat{\theta} + u_\phi \hat{\phi} + u_{x^0} \hat{x}^0, \quad (3.2)$$

where τ is the proper time,

$$u_r = \left(1 - \frac{2GM}{c^2 r}\right)^{-1/2} \dot{r},$$

$$u_\theta = r \dot{\theta},$$

$$u_\phi = r \sin \theta \dot{\phi}$$

and

$$u_{x^0} = \left(1 - \frac{2GM}{c^2 r}\right)^{1/2} \dot{x}^0.$$

Hence, the instantaneous speed u is

$$u^2 = \left(1 - \frac{2GM}{c^2 r}\right)^{-1} \dot{r}^2 + r^2 \dot{\theta}^2 + r^2 \sin^2 \theta \dot{\phi}^2 + \left(1 - \frac{2GM}{c^2 r}\right) (\dot{x}^0)^2. \quad (3.3)$$

Also the instantaneous spacetime acceleration vector is given as

$$\bar{a} = \frac{d\bar{u}}{d\tau} \quad (3.4)$$

or

$$\bar{a} = a_r \hat{r} + a_\theta \hat{\theta} + a_\phi \hat{\phi} + a_{x^0} \hat{x}^0, \quad (3.5)$$

where

$$a_r = \left(1 - \frac{2GM}{c^2 r}\right)^{-1/2} \ddot{r} - \frac{GM}{c^2 r^2} \left(1 - \frac{2GM}{c^2 r}\right)^{-3/2} \dot{r}^2,$$

$$a_\theta = r \ddot{\theta} + \dot{r} \dot{\theta},$$

$$a_\phi = \dot{r} \sin \theta \dot{\phi} + r \cos \theta \dot{\theta} \dot{\phi} + r \sin \theta \ddot{\phi}$$

and

$$a_{x^0} = \frac{d}{d\tau} \left[\left(1 - \frac{2GM}{c^2 r}\right)^{1/2} \dot{x}^0 \right].$$

Now, recall that the inertial mass m_I and passive mass m_p are related to the rest mass m_0 of a particle by

$$m_I = m_p = \left(1 - \frac{u^2}{c^2}\right)^{-1/2} m_0 \quad (3.6)$$

where in this gravitational field, u^2 is as defined in equation (3.3). Also, the linear momentum of a particle of nonzero rest mass is defined as

$$\bar{P} = m_I \bar{u} \quad (3.7)$$

or

$$\bar{P} = \left(1 - \frac{u^2}{c^2}\right)^{-1/2} m_0 \bar{u}. \quad (3.8)$$

The instantaneous relativistic kinetic energy (T) of a particle of nonzero rest mass is given as

$$T = (m_I - m_0) c^2 \quad (3.9)$$

or

$$T = \left[\left(1 - \frac{u^2}{c^2}\right)^{-1/2} - 1 \right] m_0 c^2 \quad (3.10)$$

and the instantaneous relativistic gravitational potential energy (V_g) for a particle of nonzero rest mass is

$$V_g = m_p \Phi = - \left(1 - \frac{u^2}{c^2}\right)^{-1/2} \frac{GMm_0}{r}, \quad (3.11)$$

where $\Phi = \frac{-GM}{r}$ is the gravitational scalar potential in Schwarzschild's gravitational field. Thus, the total relativistic mechanical energy E for a particle of nonzero rest mass is given as

$$E = T + V_g \quad (3.12)$$

or

$$E = m_0 c^2 \left[\left(1 - \frac{GM}{c^2 r}\right) \left(1 - \frac{u^2}{c^2}\right)^{-1/2} - 1 \right]. \quad (3.13)$$

Thus, our expression for total energy has post Newton and post Einstein correction terms of all orders of c^{-2} .

The relativistic dynamical equation of motion for particles of non-zero rest mass[2] is given as

$$\frac{d}{d\tau} \bar{P} = -m_p \bar{\nabla} \Phi \quad (3.14)$$

or

$$\frac{d}{d\tau} \left[\left(1 - \frac{u^2}{c^2}\right)^{-1/2} m_0 \bar{u} \right] = - \left(1 - \frac{u^2}{c^2}\right)^{-1/2} m_0 \bar{\nabla} \Phi \quad (3.15)$$

or

$$\bar{a} + \frac{1}{2c^2} \left(1 - \frac{u^2}{c^2}\right)^{-1} \frac{d}{d\tau} (u^2) \bar{u} = -\bar{\nabla} \Phi. \quad (3.16)$$

Thus, the spacetime relativistic dynamical equations of motion in static spherically symmetric gravitational field can be obtained from (3.16). The time equation of motion is obtained as

$$a_{x^0} + \frac{1}{2c^2} \left(1 - \frac{u^2}{c^2}\right)^{-1} \frac{d}{d\tau} (u^2) u_{x^0} = 0 \quad (3.17)$$

or

$$\frac{d}{d\tau} \left[\left(1 - \frac{2GM}{c^2 r}\right)^{1/2} \dot{x}^0 \right] + \frac{1}{2c^2} \left(1 - \frac{u^2}{c^2}\right)^{-1} \frac{d}{d\tau} (u^2) u_{x^0} = 0. \quad (3.18)$$

Notice that the first term of equation (3.18) is exactly the expression obtained for the general relativistic time dilation and hence the second term is a correction term obtained from our dynamical approach in Schwarzschild's gravitational field.

Also, the respective azimuthal, polar and radial equations of motion are obtained as

$$\begin{aligned} & \dot{r} \sin \theta \dot{\phi} + r \cos \theta \dot{\theta} \dot{\phi} + r \sin \theta \ddot{\phi} \\ & + \frac{1}{2c^2} \left(1 - \frac{u^2}{c^2}\right)^{-1} \frac{d}{d\tau} (u^2) u_\phi = 0, \end{aligned} \quad (3.19)$$

$$r \ddot{\theta} + \dot{r} \dot{\theta} + \frac{1}{2c^2} \left(1 - \frac{u^2}{c^2}\right)^{-1} \frac{d}{d\tau} (u^2) u_\theta = 0 \quad (3.20)$$

and

$$\begin{aligned} & a_r + \frac{1}{2c^2} \left(1 - \frac{u^2}{c^2}\right)^{-1} \frac{d}{d\tau} (u^2) u_r \\ & = -\frac{GM}{r^2} \left(1 - \frac{2GM}{c^2 r}\right)^{-1/2} \end{aligned} \quad (3.21)$$

with correction terms not found in the general relativistic approach.

4 Relativistic Dynamical Theory for Photons

The instantaneous passive and inertial mass of photons is given as

$$m_p = m_I = \frac{h\nu}{c^2}, \quad (4.1)$$

where h is Planck's constant. Precisely, as in Special Relativity, we postulate that the relativistic dynamical linear momentum of photons is given as

$$\bar{P} = \frac{h\nu}{c^2} \bar{u}, \quad (4.2)$$

where \bar{u} is as defined in (3.2). The relativistic dynamical kinetic energy for photons is given as

$$T = (m_I - m_0)c^2 \quad (4.3)$$

or

$$T = h(\nu - \nu_0). \quad (4.4)$$

Also, as in Newton's dynamical theory of classical mechanics, the relativistic dynamical gravitational potential energy of photons (V_g) is postulated to be given by

$$V_g = m_p \Phi. \quad (4.5)$$

Hence, in static spherically symmetric gravitational fields

$$V_g = -\frac{h\nu GM}{c^2 r}. \quad (4.6)$$

Thus, the total mechanical energy E of a photon is given as

$$E = h(\nu - \nu_0) - \frac{h\nu GM}{c^2 r}. \quad (4.7)$$

If the mechanical energy of the photon is E_0 at $r = r_0$ then using the principle of conservation of mechanical energy it can be deduced that

$$\nu = \frac{E_0}{h} \left(1 - \frac{GM}{c^2 r}\right)^{-1} \quad (4.8)$$

or

$$\nu = \nu_0 \left(1 - \frac{GM}{c^2 r_0}\right) \left(1 - \frac{GM}{c^2 r}\right)^{-1}. \quad (4.9)$$

Equation (4.9) is our newly derived expression for gravitational spectral shift for static spherically symmetric mass distributions with post Newtonian and post Einstein corrections of all orders of c^{-2} .

Also, the relativistic dynamical equation of motion for photons in static spherically symmetric gravitational fields can be obtained as

$$\frac{d}{d\tau} \left[\left(1 - \frac{GM}{c^2 r}\right)^{-1} \bar{u} \right] = - \left(1 - \frac{GM}{c^2 r}\right)^{-1} \bar{\nabla} \Phi \quad (4.10)$$

from which the instantaneous velocity and acceleration vectors can be obtained.

5 Conclusion

Instructively, this approach unifies the dynamical and geometrical theories of gravitation for test particles and photons in static spherically symmetric gravitational fields. It is hoped that if it is well developed it can account for most corrections of theoretical results in gravitational fields. It is also hoped that this approach can also be used to establish the long desired unification of gravitational fields with other fundamental fields in nature.

Submitted on October 4, 2011 / Accepted on October 13, 2011

References

1. Bergmann P.G. Introduction to the Theory of Relativity, Prentice Hall, New Delhi, 1987.
2. Howusu S.X.K. Complete Dynamical Theories of Physics, Jos University Press, Jos, 2010.
3. Howusu S.X.K. The 210 astrophysical solutions plus 210 cosmological solutions of Einstein's geometrical gravitational field equations. Jos University Press, Jos, 2007.
4. Schwarzschild K. Über das Gravitationsfeld eines Massenpunktes nach der Einsteinschen Theorie. *Sitzungsberichte der Königlich Preussischen Akademie der Wissenschaften*, 1916, 189–196 (published in English as: Schwarzschild K. On the gravitational field of a point mass according to Einstein's theory. *Abraham Zelmanov Journal*, 2008, v. 1, 10–19).

The Turning Point for the Recent Acceleration of the Universe with a Cosmological Constant

T. X. Zhang

Department of Physics, Alabama A & M University, Normal, Alabama, U.S.A.
E-mail: tianxi.zhang@aamu.edu

The turning point and acceleration expansion of the universe are investigated according to the standard cosmological theory with a non-zero cosmological constant. Choosing the Hubble constant H_0 , the radius of the present universe R_0 , and the density parameter in matter $\Omega_{M,0}$ as three independent parameters, we have analytically examined the other properties of the universe such as the density parameter in dark energy, the cosmological constant, the mass of the universe, the turning point redshift, the age of the present universe, and the time-dependent radius, expansion rate, velocity, and acceleration parameter of the universe. It is shown that the turning point redshift is only dependent of the density parameter in matter, not explicitly on the Hubble constant and the radius of the present universe. The universe turned its expansion from past deceleration to recent acceleration at the moment when its size was about 3/5 of the present size if the density parameter in matter is about 0.3 (or the turning point redshift is 0.67). The expansion rate is very large in the early period and decreases with time to approach the Hubble constant at the present time. The expansion velocity exceeds the light speed in the early period. It decreases to the minimum at the turning point and then increases with time. The minimum and present expansion velocities are determined with the independent parameters. The solution of time-dependent radius shows the universe expands all the time. The universe with a larger present radius, smaller Hubble constant, and/or smaller density parameter in matter is elder. The universe with smaller density parameter in matter accelerates recently in a larger rate but less than unity.

1 Introduction

The measurements of type Ia supernovae to appear fainter and thus further away than expected have indicated that the universe turned its expansion from past deceleration to recent acceleration [1-4]. The dark energy, a hypothetical form of negative pressure, is generally suggested to be the cause for the universe to accelerate recently. The Einsteinian cosmological constant Λ , initially assumed for a static model of the universe, is the simplest candidate of the dark energy [5]. Quintessence such as the scalar field from the scalar-tensor theory or the five-dimensional Kaluza-Klein unification theory is usually considered as another candidate of the dark energy [6-9]. In the black hole universe model, proposed recently by the author, the dark energy is nothing but the accretion of mass in an increasing time rate from outside space, the mother universe [10-17]. In the black hole universe model, the cosmological constant can be represented as $\Lambda = 3(\dot{M}/M)^2$, where M is the universe mass and \dot{M} is the time rate of the universe mass. However, when the universe turns or what the redshift of the turning point for the universe to turn its expansion from past deceleration to recent acceleration has not yet been consistently and precisely determined.

The turning point redshift Z_{TP} was determined to be ~ 0.5 by combining the redshift and luminosity observations of type Ia supernovae with the standard model of cosmology [2, 4]. The universe was considered to be flat (i.e., $k = 0$ with k the

curvature of the universe) with a cold dark matter (CDM) and a constant dark energy density (i.e., the cosmological constant). To explain the measurements of type Ia supernovae with the flat universe model, the density parameters in matter and dark energy ($\Omega_{M,0}$ and $\Omega_{\Lambda,0}$) at the present time (t_0) were chosen to be

$$\Omega_{M,0} \equiv \frac{8\pi G\rho_M(t_0)}{3H_0^2} = 0.3, \quad (1)$$

$$\Omega_{\Lambda,0} \equiv \frac{\Lambda}{3H_0^2} = 0.7, \quad (2)$$

where G is the gravitational constant, $\rho_{M,0}$ is the mass density, and $H_0 \sim 50 - 70$ km/s/Mpc is the Hubble constant [18-21]. For a holographic dark energy, the turning point redshift depends on a free parameter [22]. The turning point redshift is $Z_{TP} \sim 0.72$ if the free parameter is chosen to be unity. For the best fit to the type Ia supernova data, the free parameter is around 0.2, which leads to a smaller turning point redshift, $Z_{TP} \sim 0.28$.

To combine the measurements of type Ia supernovae with the cosmological model, a redshift-luminosity distance relation is required. The often used relation is, however, a linearly approximate relation,

$$d_L(Z) \simeq c(1+Z) \int_0^Z \frac{du}{H(u)}, \quad (3)$$

which is only good for nearby objects (see the detail of the standard derivation given by [23]). Using this approximate redshift-luminosity distance relation to study the expansion of the universe constrained by the measurements of type Ia supernovae with redshift greater than unity, one cannot accurately determine the turning point redshift [24] (Zhang and tan 2007). In Eq. (3), c is the light speed, Z is the redshift of light from the object, and d_L is the luminosity, which is usually defined by

$$F = \frac{L}{4\pi d_L^2}, \quad (4)$$

where L is the luminosity of the object such as a supernova, F is the apparent brightness of the object (i.e., the object emission flux measured at the Earth).

In this study, we analytically derive the turning point redshift only from the cosmological model without combining the model with the type Ia supernova data of measurements and thus without using the approximate redshift-luminosity distance relation. The simplest cosmological model that describes the recent acceleration of the universe is governed by the Friedmann equation with a non-zero Einsteinian cosmological constant [1-2, 5]. The expansion characteristics of the universe described by this constant Λ CDM model depend on three independent parameters. There are many different ways or combinations to choose the three independent parameters. But no matter how to combine, the number of independent parameters is always three. We have chosen the Hubble constant H_0 , the radius of the present universe R_0 , and the density parameter in matter $\Omega_{M,0}$ as the three independent parameters and have further derived the turning point redshift. The derived turning point redshift is only dependent of the density parameter in matter $\Omega_{M,0}$, not dependent of the other two independent parameters R_0 and H_0 if the universe is flat.

Exact solutions of the Friedmann equation [25-26] with the cosmological constant were obtained by [27-28]. The physical solutions, however, have not yet been analyzed with the recent measurements of the universe, especially on the turning point redshift.

The objective of this study is to quantitatively study the turning point and expansion characteristics of the recent acceleration universe through analyzing and numerically solving the Friedmann equation with a non-zero cosmological constant. First, for each set of H_0 , $\Omega_{M,0}$, and R_0 , we analytically obtain the turning point redshift Z_{TP} and other cosmological parameters such as the density parameter in dark energy $\Omega_{\Lambda,0}$, the cosmological constant Λ , and the mass of the universe M . Then, we substitute the obtained M and Λ into the Friedmann equation to numerically solve the time-dependent expansion rate or Hubble parameter $H(t)$, velocity $v(t)$, radius $R(t)$, and acceleration parameter $q(t)$ of the universe. Third, from the solutions, we determine the age of the present universe. Finally, we discuss the significant results and summarize our concluding remarks.

2 Turning Point and Expansion Characteristics of the Universe

According to the standard cosmological theory, the expansion of the universe is governed by the Friedmann equation [25-26, 29]

$$H^2(t) \equiv \frac{\dot{R}^2(t)}{R^2(t)} = \frac{8\pi G\rho_M(t)}{3} - \frac{kc^2}{R^2(t)} + \frac{\Lambda}{3}, \quad (5)$$

(Friedmann 1922, 1924; Carroll et al. 1992) where the dot refers to the derivative with respect to time, G is the gravitational constant, $\rho_M(t)$ is the density of matter given by

$$\rho_M(t) = \frac{3M}{4\pi R^3(t)}, \quad (6)$$

and k is the curvature of the space given by -1, 0, 1 for the universe to be open, flat, and closed, respectively. For the flat universe (i.e., $k = 0$), Eq. (5) becomes

$$H^2(t) \equiv \frac{\dot{R}^2(t)}{R^2(t)} = \frac{2GM}{R^3(t)} + \frac{\Lambda}{3}. \quad (7)$$

The solution of Eq. (7) depends on three independent parameters: R_0 , M , and Λ . There are many different combinations that can be considered as the three independent parameters such as (R_0, H_0, Λ) , $(R_0, H_0, \Omega_{M,0})$, etc. In this study, we have chosen R_0 , H_0 , and $\Omega_{M,0}$ as the three independent parameters.

To describe the acceleration of the universe, we define the acceleration parameter as

$$q(t) \equiv \frac{R(t)\ddot{R}(t)}{\dot{R}^2(t)} = 1 + \frac{\dot{H}(t)}{H^2(t)}. \quad (8)$$

Traditionally, a negative sign is inserted in Eq. (8) for the deceleration parameter.

A light that was emitted at time t is generally shifted towards the red when it is observed at the present time t_0 due to the expansion of the universe. The redshift of the light is given by

$$Z_H = \frac{R(t_0)}{R(t)} - 1. \quad (9)$$

The recent acceleration universe turned its expansion from past deceleration to recent acceleration at the moment when the acceleration parameter is equal to zero, i.e.,

$$q(t_{TP}) = 0, \quad (10)$$

where t_{TP} is defined as the turning point - the time when the universe neither accelerates nor decelerates. It has been recognized for years but not yet theoretically determined.

Differentiating Eq. (7) with respect to time to get $\dot{H}(t)$ and using the turning point condition (10), we have the following relation

$$\Lambda = \frac{3GM}{R^3(t_{TP})}. \quad (11)$$

Then, using Eq. (9), we have

$$\Lambda = \frac{3GM}{R^3(t_0)} \left(\frac{R^3(t_0)}{R^3(t_{TP})} \right) = \frac{3GM}{R_0^3} (Z_{TP} + 1)^3, \quad (12)$$

where we have replaced $R(t_0)$ by R_0 and denoted the redshift of observed light that was emitted at the turning point by Z_{TP} - the turning point redshift. From Eq. (12), the turning point redshift can be written as

$$Z_{TP} = \left(\frac{\Lambda R_0^3}{3GM} \right)^{1/3} - 1. \quad (13)$$

At the present time t_0 , Eq. (7) can be written as

$$1 = \Omega_{M,0} + \Omega_{\Lambda,0}, \quad (14)$$

where the density parameters in matter and dark energy are defined respectively by

$$\Omega_{M,0} = \frac{8\pi G\rho_M(t_0)}{3H_0^2} = \frac{2GM}{H_0^2 R_0^3}, \quad (15)$$

and

$$\Omega_{\Lambda,0} = \frac{\Lambda}{3H_0^2}. \quad (16)$$

From Eqs. (15)-(16), we obtain

$$\frac{\Lambda R_0^3}{3GM} = 2 \frac{1 - \Omega_{M,0}}{\Omega_{M,0}}. \quad (17)$$

Then, Eq. (13) reduces

$$Z_{TP} = \left(2 \frac{1 - \Omega_{M,0}}{\Omega_{M,0}} \right)^{1/3} - 1. \quad (18)$$

Eq. (18) is a new result and has not been obtained before by any one. It is seen from Eq. (18) that the turning point redshift Z_{TP} is only dependent of the density parameter in matter Ω_M , not explicitly on another two independent parameter H_0 and R_0 .

Figure 1 plots Z_{TP} as a function of Ω_M . The result indicates that, for the universe to be recently turned (i.e., $Z_{TP} > 0$), the density parameter in matter must be $\Omega_{M,0} < 2/3$ (or $\Omega_{\Lambda,0} > 1/3$). For the universe to be turned at $1 \gtrsim Z_{TP} \gtrsim 0.5$, the density parameter in matter must be $0.2 \lesssim \Omega_M \lesssim 0.4$. When $\Omega_{M,0} = 1$, we have $Z_{TP} = -1$, which implies that the flat universe will never be accelerated if the cosmological constant is zero. This is consistent with the gravitational physics because gravity always attracts.

Considering H_0 , R_0 , and $\Omega_{M,0}$ as three independent parameters in the flat universe model, we can determine Ω_{Λ} , M , Λ , and Z_{TP} by Eqs. (14)-(16) and (18). Substituting the determined M and Λ into Eq. (7), we can numerically solve the expansion parameters of the recent acceleration universe

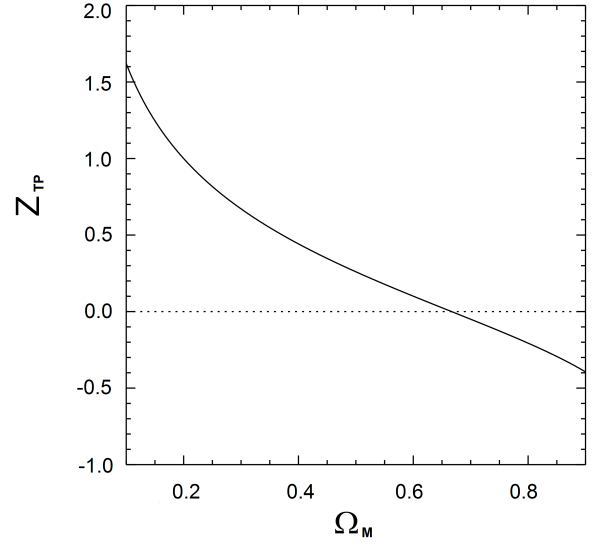

Fig. 1: Turning point redshift Z_{TP} versus density parameter in matter $\Omega_{M,0}$.

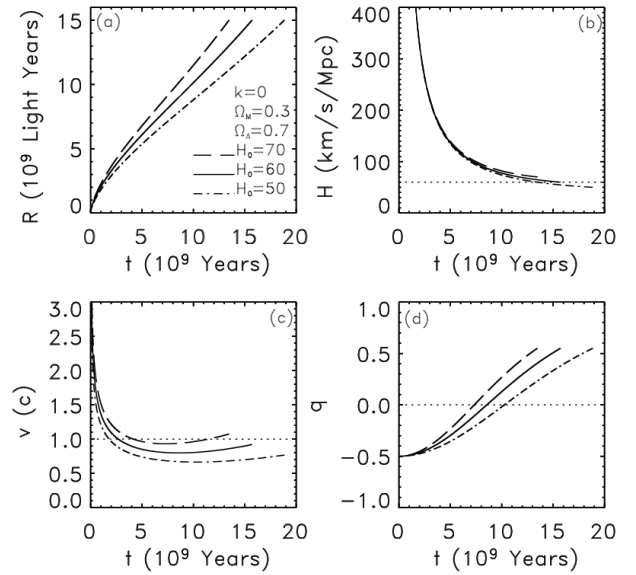

Fig. 2: Expansion characteristics of the universe when $\Omega_{M,0} = 0.3$, $R_0 = 15$ billion light years, and $H_0 = 50, 60, 70$ km/s/Mpc. (a) Radius of the universe $R(t)$, (b) expansion rate $H(t)$, (c) expansion velocity $v(t)$, (d) acceleration parameter $q(t)$.

including the radius $R(t)$, expansion rate $H(t)$, expansion velocity $v(t)$, and acceleration parameter $q(t)$.

Figure 2 plots these expansion parameters - $R(t)$, $H(t)$, $v(t)$, and $q(t)$ - as functions of time. We have chosen $H_0 = 50, 60, 70$ km/s/Mpc, $\Omega_{M,0} = 0.3$, and $R_0 = 15$ billion light years, which are displayed in Figure 2a. Three types of lines (dotted-dashed, solid, and dashed) correspond to the results with three different Hubble constants. With these three sets

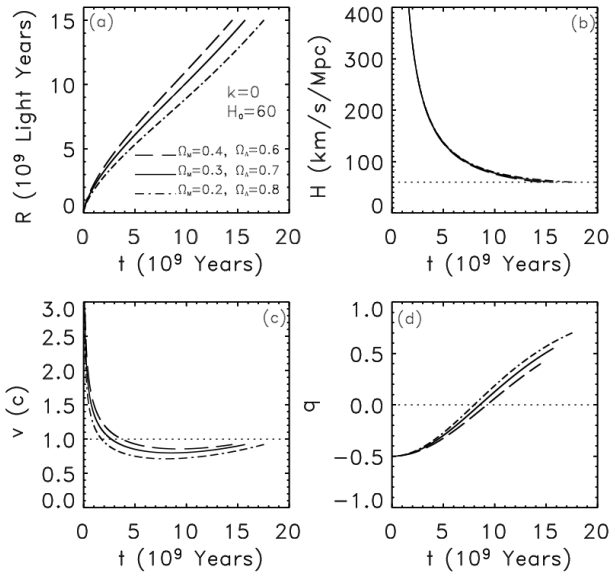

Fig. 3: Expansion characteristics of the universe when $\Omega_{M,0} = 0.2, 0.3, 0.4$ and $H_0 = 60$ km/s/Mpc with the same R_0 . (a) Radius of the universe $R(t)$, (b) expansion rate $H(t)$, (c) expansion velocity $v(t)$, (d) acceleration parameter $q(t)$.

of parameters, we have $M = 1.7, 2.4, 3.3 \times 10^{53}$ kg, $\Lambda = 5.5, 8.0, 10.8 \times 10^{-36}$ s $^{-2}$, $\Omega_{\Lambda,0} = 0.7$, and $Z_{TP} = 0.67$.

Figure 2a shows that $R(t)$ increases with time to approach R_0 at the present time t_0 . In comparison with a linear relation, the radius-time curves bend down at $R \lesssim 3R_0/5$ and then slightly go up at $R \gtrsim 3R_0/5$. The flat universe turned its expansion from past deceleration to recent acceleration at the time when the size of the universe was about three-fifth of the present universe (i.e., at $Z_{TP} \approx 2/3$) due to the dark energy or non-zero cosmological constant. Figure 2b indicates that the expansion rate or Hubble parameter $H(t)$ decreases with time (or $\dot{H}(t) < 0$) to approach the Hubble constant H_0 at the present time. The dotted line refers to $H_0 = 60$ km/s/Mpc. Figure 2c shows that the expansion velocity decreases with time to the minimum at the turning point and then increases with time to approach $v_0 = H_0 R_0$, which exceeds the light speed in the case of $H_0 = 70$ km/s/Mpc and $R_0 = 15$ billion light years. In the early period, the expansion velocity can be much greater than the light speed. The minimum expansion velocity is determined by $v_{\min} = (2GM)^{1/3} \Lambda^{1/6}$. From Figure 2d, that the universe turned its expansion from past deceleration to recent acceleration can be seen in more obviously. The dotted line refers to $q = 0$. Each curve of $q(t)$ intersects with the dotted line at the turning point. For a different Hubble constant, the turning point t_{TP} is different. The acceleration parameter is negative (i.e., deceleration) before the turning point and positive (i.e., acceleration) after the turning point. At the present time, the acceleration parameter is slightly over 0.5.

Figure 3 also plots the four expansion parameters $R(t)$,

$H(t)$, $v(t)$, and $q(t)$ as functions of time. In this plot, we have chosen a single $H_0 = 60$ km/s/Mpc but three $\Omega_M = 0.2, 0.3, 0.4$ with the same R_0 . The three types of lines correspond to the results with three different density parameters. With these three sets of parameters, we have $M = 2.4 \times 10^{53}$ kg, $\Lambda = 8.0 \times 10^{-36}$ s $^{-2}$, $\Omega_{\Lambda,0} = 0.8, 0.7, 0.6$, and $Z_{TP} = 1, 0.67, 0.5$. The results are basically similar to Figure 2. The turning point redshift is single in the case of Figure 2 but multiple in the case of Figure 3. The radius-time curves (Figure 3a) also bend down relative to the linear relation in the past and go up recently, which implies that the flat universe was decelerated in the past and accelerated recently. The decreasing profiles of expansion rate $H(t)$ with time only slightly different among different density parameters (Figure 3b). The expansion velocity reaches the minimum v_{\min} at the turning point and approaches v_0 at t_0 (Figure 3c). The acceleration parameter at t_0 is greater if the universe contains more dark energy relative to matter (Figure 3d). For a different density parameter, the turning point t_{TP} is different. The acceleration parameter is negative (i.e., deceleration) before the turning point and positive (i.e., acceleration) after the turning point.

From Figures 2 and 3, we can find the present time or the age of the present universe with $R_0 = 15$ billion light year. For a different H_0 or $\Omega_{M,0}$, the age of the present universe should be different. The age of the present universe determined based on Figures 2 and 3 is plotted as a function of H_0 in Figure 4a and as a function of $\Omega_{M,0}$ in Figure 4b. It is seen that the age of the present universe decreases with H_0 and $\Omega_{M,0}$ when R_0 is fixed. For $R_0 = 15$ billion light year, $H_0 = 50 - 70$ km/s/Mpc, and $\Omega_{M,0} = 0.3$, the age of the universe is in the range of $\sim 13 - 19$ billion years, slightly less than H_0^{-1} . The universe is elder if it turned earlier (i.e., smaller $\Omega_{M,0}$) or has a smaller expansion rate.

3 Discussions and Conclusions

The open or closed universe can also be recently accelerated by the dark energy. Since k is not zero, the density parameters will be quite different in order for the universe to be turned from deceleration to acceleration at a similar turning point. The details on the turning point and expansion characteristics of the open and closed universes will be studied in future.

Consequently, the turning point and accelerating expansion of the flat universe has been investigated according to the cosmological theory with a non-zero cosmological constant. Choosing six sets of H_0 , R_0 , and $\Omega_{M,0}$, we have quantitatively determined $\Omega_{M,0}$, Λ , M , Z_{TP} , t_0 , $R(t)$, $H(t)$, $v(t)$, and $q(t)$. Analyzing these results, we can conclude the following remarks.

To turn the expansion from deceleration to acceleration, the flat universe must contain enough amount of dark energy $\Omega_{\Lambda,0} > 1/3$. The turning point redshift depends only on the density parameter in matter $Z_{TP} = [2(1 - \Omega_{M,0})/\Omega_{M,0}]^{1/3} - 1$. The flat universe will never be accelerated if the cosmologi-

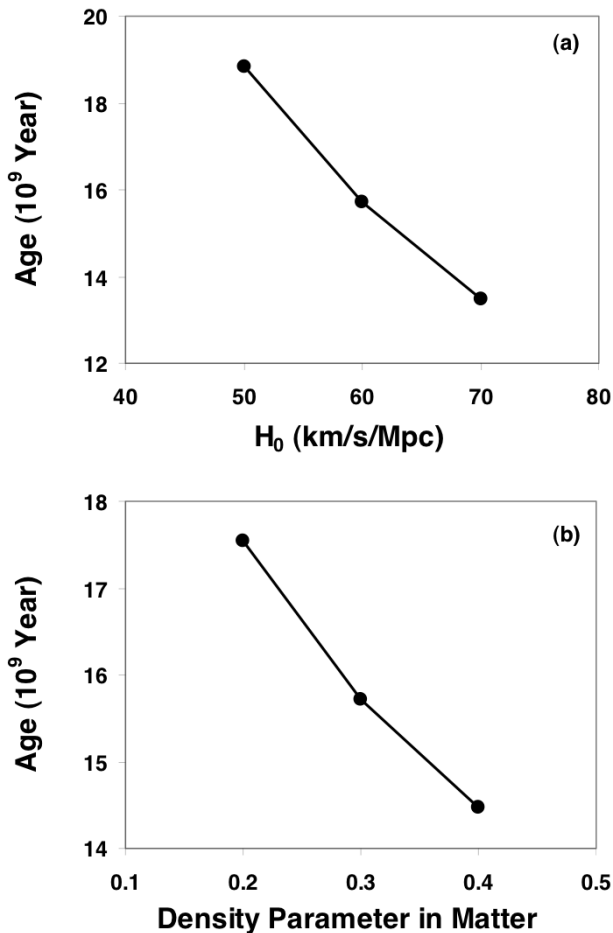

Fig. 4: Age of the universe as a function of H_0 (a) and $\Omega_{M,0}$ (b).

cal constant is zero. For the flat universe to be turned from deceleration to acceleration at $0.5 \lesssim Z_{TP} \lesssim 1$, the density parameter in matter must be $0.4 \gtrsim \Omega_{M,0} \gtrsim 0.2$. The radius of the universe generally increases with time. The expanding profiles are belong to the M_1 type of exact solutions given by [27-28]. The expansion rate of the universe rapidly decreases with time to approach the Hubble constant. The expansion velocity decreases with time to the minimum $v_{\min} = (2GM)^{1/3} \Lambda^{1/6}$ at the turning point and then increases with time to approach $v_0 = H_0 R_0$. The acceleration parameter also increases with time and changes from negative to positive at the turning point. The acceleration of the present universe is larger if it contains more dark energy. The age of the universe depends on all of R_0 , H_0 , and $\Omega_{M,0}$. The flat universe with a fixed R_0 should be elder for smaller H_0 or $\Omega_{M,0}$ due to the expansion velocity smaller.

Overall, this study has shown the constraints and characteristics of the recent acceleration universe, which deepens our understanding of the turning and accelerating of the universe from past deceleration to recent acceleration.

Acknowledgement

This work was supported by the NASA research and education program (NNG04GD59G), NASA EPSCoR program (NNX07AL52A), NSF CISM program, Alabama A & M University Title III program, National Natural Science Foundation of China (G40890161).

Submitted on January 26, 2012 / Accepted on February 3, 2012

References

1. Riess, A.G. et al. Observational Evidence from Supernovae for an Accelerating Universe and a Cosmological Constant. *Astronomical Journal*, 1998, v. 116, 1009–1038.
2. Riess, A.G. et al. Type Ia Supernova Discoveries at $Z > 1$ from the Hubble Space Telescope Evidence for Past Deceleration and Constraints on Dark Energy Evolution. *Astrophysical Journal*, 2004, v. 607, 665–687.
3. Perlmutter, S. et al. Measurements of Omega and Lambda from 42 High-Redshift Supernovae. *Astrophysical Journal*, 1999, v. 517, 565–586.
4. Turner, M.S. and Riess, A.G. Do Type Ia Supernovae Provide Direct Evidence for Past Deceleration of the Universe? *Astrophysical Journal*, 2002, v. 569, 18–22.
5. Peebles, P.J. and Ratra, B. The Cosmological Constant and Dark Energy. *Reviews of Modern Physics*, 2003, v. 75, 559–606.
6. Brans, C.H. and Dicke, R. H. Mach's Principle and a Relativistic Theory of Gravitation. *Physical Review*, 1961, v. 124, 925–935. s
7. Arik, M. and Calik, M.C. Can Brans-Dicke Scalar Field Account for Dark Energy and Dark Matter? *Modern Physics Letters A*, 2006, v. 21, 1241–1248.
8. Sharif, M. and Khanum, F. Kaluza-Klein Cosmology with Modified Holographic Dark Energy. *General Relativity and Gravitation*, 2011, v. 43, 2885–2894.
9. Jadhav, M., Zhang, T.X. and Winebarger, A. Modified Friedmann Equation with a Scalar Field. *AAMU STEM Day*, 2009, v. 3, 66–66.
10. Zhang, T.X. A New Cosmological Model: Black Hole Universe. *BAAS*, 2007, v. 39, 1004–1004.
11. Zhang, T.X. Anisotropic Expansion of the Black Hole Universe. *BAAS*, 2009, v. 41, 499–499.
12. Zhang, T.X. A New Cosmological Model: Black Hole Universe. *Progress in Physics*, 2009, v. 2, 3–11.
13. Zhang, T.X. Cosmic Microwave Background Radiation of Black Hole Universe. *BAAS*, 2009, v. 41, 754–754.
14. Zhang, T.X. Observational Evidences of Black Hole Universe. *BAAS*, 2010, v. 42, 314–314.
15. Zhang, T.X. Cosmic Microwave Background Radiation of Black Hole Universe. *ApSS*, 2010, v. 330, 157–165.
16. Zhang, T.X. Black Hole Universe and Dark Energy. *BAAS*, 2011, v. 43, 2011–2011.
17. Zhang, T.X. Mechanism for Gamma Ray Bursts and Black Hole Universe Model. *AAS 219th Meeting*, 2012, Abstract # 310.02.
18. Hughes, J.P. and Birkinshaw, M. A Measurement of Hubble Constant from the X-Ray Properties and the Sunyaev-Zeldovich Effect of CL 0016+16. *Astrophysical Journal*, 1998, v. 501, 1–14.
19. Mauskopf, P.D. et al. A Determination of the Hubble Constant Using Measurements of X-Ray Emission and the Sunyaev-Zeldovich Effect at Millimeter Wavelengths in the Cluster Abell 1835. *Astrophysical Journal*, 2000, v. 538, 505–516.
20. Macri, L.M., Stanek, K.Z., Bersier, D., Greenhill, L.J., and Reid, M.J. A New Cepheid Distance to the Maser-Host Galaxy NGC 4258 and Its Implications for the Hubble Constant. *Astrophysical Journal*, 2006, v. 652, 1133–1149.

21. Sandage, A., Tammann, G.A., Saha, A., Reindl, B., Macchetto, F.D., and Panagia, N. The Hubble Constant: A Summary of the Hubble Space Telescope Program for the Luminosity Calibration of Type Ia Supernovae by Means of Cepheids. *Astrophysical Journal*, 2006, v. 653, 843–860.
 22. Huang, Q.G., Gong, Y.G. Supernova Constraints on a Holographic Dark Energy Model. *JCAP*, 2004, v. 8, 6–10.
 23. Weinberg, S. Gravitation and Cosmology. John Wiley and Sons, New York, 1972, pp.419-422.
 24. Zhang, T.X., and Tan, A. The Turning and Evolution of the Recent Acceleration Universe. *BAAS*, 2007, v. 38, 241–241.
 25. Friedmann, A.A. Über die Krümmung des Raumes. *Zeitschrift für Physik*, 1922, v. 10, 377–386.
 26. Friedmann, A.A. Über die Möglichkeit einer Welt mit konstanter negativer Krümmung des Raumes. *Zeitschrift für Physik*, 1924, v. 21, 326–332.
 27. Kharbediya, L.I. Some Exact Solutions of the Friedmann Equations with the Cosmological Term. *Soviet Astronomy*, 1976, v. 20, 647.
 28. Kharbediya, L.I. Solutions to the Friedmann Equations with the Lambda Term for a Dust-Radiation Universe. *Soviet Astronomy*, 1983, v. 27, 380–383.
 29. Carroll, S.M., Press, W.H., Turner, E.L. The Cosmological Constant. *AR&AA*, 1992, v. 30, 499–542.
-

Anisotropic to Isotropic Phase Transitions in the Early Universe

Muhammad Adeel Ajaib

Department of Physics and Astronomy, University of Delaware, Newark, Delaware 19716

E-mail: adeel@udel.edu

We attempt to develop a minimal formalism to describe an anisotropic to isotropic transition in the early Universe. Assuming an underlying theory that violates Lorentz invariance, we start with a Dirac like equation, involving four massless fields, and which does not exhibit Lorentz invariance. We then perform transformations that restore it to its covariant form along with a mass term for the fermion field. It is proposed that these transformations can be visualized as waves traveling in an anisotropic media. The transformation $it/\hbar \rightarrow \beta$ is then utilized to transit to a statistical thermodynamics system and the partition function then gives a better insight into the character of this transition. The statistical system hence realized is a two level system with each state doubly degenerate. We propose that modeling the transition this way can help explain the matter antimatter asymmetry of the Universe.

1 Introduction

The idea that the Universe is homogeneous, isotropic and that space-time is Lorentz invariant are important pillars of theoretical physics. Whereas the cosmological principal assumes the Universe to be homogeneous and isotropic, Lorentz invariance is required to be a symmetry of any relativistic quantum field theory. These requirements have robust footings, but there can possibly be scenarios where these ideas are not sufficient to describe the dynamics of a system. Temperature fluctuations in the Cosmic Microwave Background (CMB) radiation indicate that the assumptions made by the cosmological principal are not perfect. There is no conclusive evidence of Lorentz violation to date but this has been a topic of considerable interest and the Standard Model Extension (SME) has been constructed which includes various terms that preserve observer Lorentz transformations but violate particle Lorentz transformations [1]. Limits have been placed on the coefficients of various terms in the SME as well [2]. Another important question is the matter-antimatter asymmetry of the Universe which is not completely resolved. Sakharov, in 1967 derived three conditions (baryon violation, C and CP violation and out of thermal equilibrium) for a theory to satisfy in order to explain the baryon asymmetry of the Universe.

Origin of fermion masses is also one of the most intriguing questions which is now close to be answered by the ATLAS and CMS experiments at the Large Hadron Collider. Hints of this particle have been seen and we will know for sure this year, hopefully mid 2012, whether it exists or not. If the Higgs does not exist than the formalism presented in this article can also serve as a possible explanation for the origin of mass of fermions.

In this paper we intend to describe the evolution of a theory that violates Lorentz invariance to a theory that preserves it. The fields that are involved in the Lorentz violating theory can be viewed in analogy with fields traveling in

an anisotropic medium. When the system evolves from the anisotropic to isotropic phase the symmetry of the theory is restored and the partition function formalism can be used to better understand how this transition takes place. This formalism, we propose, can help explain the matter-antimatter asymmetry of the Universe. The paper is organized as follows: In section 2 and 3 we describe these transformations and propose a way to interpret them as plane wave transitions into anisotropic media. In section 4 the partition function is used to get a better insight into how the transformations in section 2 occur and we conclude in section 5.

2 Transformations leading to Covariant Dirac equation

In this section we outline a set of transformations that lead to the Dirac equation for a QED (Quantum Electrodynamics) like theory with no interaction terms. We start with a Dirac-like equation which involves four fields ($\chi_a, \chi_b, \chi_c, \chi_d$). These fields can be redefined in a simple way such that the covariant form of the Dirac equation is restored along with a mass term. We assume a minimal scenario and consider just the kinetic terms for the fields in the underlying theory. If we start with the following equation ($\hbar = c = 1$):

$$i\bar{\chi}_a\gamma^0\partial_0\chi_a + i\bar{\chi}_b\gamma^1\partial_1\chi_b + i\bar{\chi}_c\gamma^2\partial_2\chi_c + i\bar{\chi}_d\gamma^3\partial_3\chi_d = 0, \quad (1)$$

and transform each of the χ fields in the following manner,

$$\begin{aligned} \chi_a(x) &\rightarrow e^{i\alpha m\gamma^0 x_0}\psi(x), & \chi_b(x) &\rightarrow e^{i\beta m\gamma^1 x_1}\psi(x), \\ \chi_c(x) &\rightarrow e^{i\delta m\gamma^2 x_2}\psi(x), & \chi_d(x) &\rightarrow e^{i\sigma m\gamma^3 x_3}\psi(x), \end{aligned} \quad (2)$$

we get the Dirac equation in covariant form, along with a mass term (using, for e.g., $e^{i\beta m\gamma^1 x_1}\gamma_0 = \gamma_0 e^{-i\beta m\gamma^1 x_1}$),

$$\bar{\psi}[i\gamma^\mu\partial_\mu - (\alpha + \beta + \delta + \sigma)m]\psi = 0, \quad (3)$$

where α, β, δ and σ are real positive constants. For plane wave solution for particles, $\psi = e^{-ip \cdot x}u(p)$, the above redefinition

for the field χ_a , for example, is a solution of the following equation:

$$\frac{\partial}{\partial t}\chi_a(x) = -i(E - \alpha m\gamma_0)\chi_a(x), \quad (4)$$

with similar equations for the other fields. Equation (4), is similar to equation (27) in reference [3] which is a solution of the differential equation governing linear elastic motions in an anisotropic medium (with a constant matrix, see section III of the reference). With $\alpha = 0$ the left hand side is just the Hamiltonian with the plane wave its eigenstate.

Note that the manner in which we can transform equation (1) to (3) is not unique and there are various ways to do this with different combinations of the χ fields along with the field ψ . A mass term ($m\bar{\chi}\chi$) for the χ fields could have been added to equation (1), but the redefinitions (2) can be used to eliminate it. So, if we want our resulting equation to describe a massive fermion, these fields should be massless or cannot have mass term of the form $m\bar{\chi}\chi$. This argument will be further corroborated with the results we present in section 4. The transformation matrices in equation (2) are not all unitary, the matrix $e^{i\alpha m\gamma^0 x_0}$ is unitary while the rest ($e^{i\beta m\gamma^i x_i}$) are hermitian.

The fields in equation (1) can be considered as independent degrees of freedom satisfying equation (4) in an underlying theory that violates Lorentz invariance. The transformations (2) can, therefore, be seen as reducing the degrees of freedom of the theory from four to one. In such an underlying theory, various interaction terms can be written for these fields. Since we intend to obtain the free Dirac equation, we have considered only kinetic terms involving the fields χ . A quadratic term involving different χ fields ($m\bar{\chi}_i\chi_j$) can be added to equation (1) but this leads to a term that violates Lorentz invariance in the resulting Dirac equation. A quartic term ($c\bar{\chi}_i\chi_i\bar{\chi}_j\chi_j$) is possible and would result in a dimension 6 operator for the field ψ with the constant c suppressed by the square of a cutoff scale. So, with the restriction that the resulting Dirac equation only contains terms that are Lorentz scalars the number of terms we can write for the χ fields can be limited. In other words we impose Lorentz symmetry in the resulting equation so that various terms vanish or have very small coefficients.

3 Visualizing field Redefinitions

Space-time dependent field redefinitions in the usual Dirac Lagrangian result in violation of Lorentz invariance. For example, the field redefinition $\psi \rightarrow e^{-i\alpha^\mu x_\mu}\psi$ leads to the Lorentz violating terms in the Lagrangian [1]. This particular redefinition, however, would not lead to physically observable effects for a single fermion. A transformation of this type amounts to shifting the four momentum of the field. It can also be viewed in analogy with plane waves entering another medium of a different refractive index which results in a change in the wave number of the transmitted wave. Similarly, transformations (2) can be interpreted as transitions of a wave from an

anisotropic to isotropic medium or vice versa as done in the Stroh's matrix formalism [3]. For plane wave solutions of ψ , the χ fields have propagative, exponentially decaying and increasing solutions (for example, $e^{\pm imx}$, $e^{\pm mx}$). This wave behavior is similar to that in an anisotropic medium or a medium made of layers of anisotropic medium. The eigenvalues of the Dirac matrices being the wave numbers of these waves in this case. The coefficients in the exponent relates to how fast the wave oscillates, decays and/or increases exponentially. The transfer matrix in Stroh's formalism describe the properties of the material and in this case can possibly represent the properties of the anisotropic phase from which the transition to the isotropic phase occurs.

Therefore, we can visualize a global and local transformation as transitions of plane waves to different types of media. The wave function of a particle ($E > V$) which comes across a potential barrier of a finite width and height undergoes a phase rotation ($e^{ikl}\psi$) upon transmission. If the width of the barrier extends to infinity, the wave function can be viewed as undergoing a position dependent phase rotation ($e^{ikx}\psi$). The transformations (2) can similarly be seen as a plane wave entering an anisotropic medium. Another phenomenon called birefringence in optics can be used to explain why these four fields map on to the same field ψ . Birefringence results in a plane wave splitting into two distinct waves inside a medium having different refractive indices along different directions in a crystal. These analogies can serve as crude sketches to visualize how the transformations in equation (2) can occur.

In the usual symmetry breaking mechanism a Higgs field acquires a vacuum expectation value (VEV) and the resulting mass term does not respect the symmetry of the underlying group. For example, in the Standard Model, due to its chiral nature, a Higgs field is introduced in order to manifest gauge invariance. Once the Higgs field acquires a VEV the mass term only respects the symmetry of the resulting group which is $U(1)_{EM}$. In our case the mass term arises after symmetry of the Dirac equation is restored. Consider the simple case where we have one field χ_a in addition to the field ψ :

$$i\bar{\chi}_a\gamma^0\partial_0\chi_a + i\bar{\psi}\gamma^i\partial_i\psi = 0, \quad (5)$$

and this field transforms to the field ψ as $\chi_a(x) \rightarrow e^{i\alpha m\gamma^0 x_0}\psi(x)$, leading to the Dirac equation. In order to discuss the symmetries of the above equation let's assume that the two independent degrees of freedom are described by the above equation. Equation (5) then has two independent global $U(1)$ symmetries and the resulting equation has one. In fact, there is a list of symmetries of equation (5) not possessed by (3), for example invariance under local transformations, $\chi_a \rightarrow e^{i b^i \theta(x_i)}\chi'_a$ ($i, j = 1, 2, 3$), where b_i can be a constant vector, the matrix γ_0 or any matrix that commutes with γ_0 (e.g., σ_{ij} , $\gamma_5\gamma_i$). This implies invariance under global and local $SO(3)$ transformations (rotations of the fields χ_a but not boosts). Similarly, $\psi \rightarrow e^{iA\theta(t)}\psi'$ is a symmetry, where A can be a constant or the

matrix $i\gamma_0\gamma_5$ which commutes with the three Dirac matrices γ_i . After the transformation $\chi_a \rightarrow e^{im\gamma_0 t}\psi$ the equation is no more invariant under these symmetries and the SO(1,3) symmetry of the Dirac equation is restored along with a global U(1) symmetry.

4 Partition Function as a Transfer Matrix

In the early Universe, a transition from a Lorentz asymmetric to a symmetric phase could possibly induce transformations of the form (2). Let's again consider the simple example in equation (5). For this case the eigenvalues of the Dirac matrix γ_0 define the wave numbers of the waves traveling in the anisotropic medium. The direction of anisotropy in this case is the temporal direction, which means that the time evolution of these waves is not like usual plane waves. It is not straight forward to visualize the fields, the dynamics of whom are described by the anisotropy of space time, but we can use the partition function method to get a better insight into this. We can, by using this formalism, calculate the temperature at which the transformations in equation (2) occur.

We next perform a transition to a thermodynamics system by making the transformation $it \rightarrow \beta$, where $\beta = 1/k_B T$ [4]. The partition function is then given by the trace of the transformation matrix $e^{im\gamma_0 t}$,

$$Z = \text{Tr}(e^{m\beta\gamma_0}) = 2e^{\beta m} + 2e^{-\beta m}. \quad (6)$$

This partition function is similar to that of a two-level system of spin 1/2 particles localized on a lattice and placed in a magnetic field with each state, in this case, having a degeneracy of two. The lower energy state corresponding to spin parallel to the field ($E = -m, Z_1 = e^{\beta m}$). In this case the doubly degenerate states correspond to spins up and down of the particle or anti-particle. For N distinguishable particles the partition function is Z^N , N here is the total number of particles and antiparticles of a particular species. So, we are modeling our system as being on a lattice with the spin along the field as representing a particle and spin opposite to the field representing an antiparticle.

The evolution of this system with temperature represents the time evolution of the system in equation (1). In other words the partition function describes the evolution of these waves from anisotropic to isotropic phase as the temperature decreases. For a two level system the orientation of the dipole moments becomes completely random for large enough temperatures so that there is no net magnetization. In our case we can introduce another quantity, namely a gravitational dipole, which would imply that the four states (particle/antiparticle, spin up/down) of N such particles at high enough temperatures orient themselves in a way that the system is massless. This just serves as an analogy and does not mean that the masses are orientating themselves the same way as dipoles would do in space. The anisotropic character can be seen as mimicking the behavior of the field in a two level system. The

population of a particular energy level is given by

$$n_{p(\bar{p})} = \frac{N e^{\pm\beta m}}{e^{\beta m} + e^{-\beta m}}, \quad (7)$$

which shows that the number density of particles and antiparticles vary in a different way with respect to temperature. In the early Universe, therefore the anisotropic character of space-time seems to play an important role such that particles and anti-particles behave in different manners. As the temperature decreases the number density of the anti-particles decreases and is vanishingly small for small temperatures ($\sim e^{-2\beta m}$). When the decoupling temperature is attained there is a difference in the number density of the particles and antiparticles as described by equation (7). This leads to an excess of particles over antiparticles. The decoupling temperature of a particular species of particle with mass m and which is non-relativistic is given by, $k_B T \lesssim 2m$. Below this temperature the particles annihilate to photons but the photons do not have enough energy to produce the pair. This can be used to get the ratio of antiparticles over particles (matter radiation decoupling). For $\beta m \approx 0.5$, we get

$$\frac{n_p - n_{\bar{p}}}{n_p} \approx 0.6, \quad (8)$$

which implies an excess of particles over antiparticles and thus can serve as another possible way to explain the matter antimatter asymmetry of the Universe. This number is very large compared to the one predicted by standard cosmology ($\sim 10^{-9}$). The above expression yields this order for $\beta m \approx 10^{-9}$ which implies a large temperature. For electrons this would imply a temperature of the order 10^{18} K which is large and the electrons are relativistic. So if we assume that the decoupling takes place at a higher temperature, the baryon asymmetry can be explained. Even without this assumption the conditions proposed by Sakharov can also enhance the number of particles over the antiparticles. Sakharov's conditions involve the interaction dynamics of the fields in the early Universe whereas in our case the statistical system serves more as a model describing the dynamics of space-time to a more ordered phase.

Statistical mechanics, therefore, enables us to visualize this transition in a rather lucid way. In a two level system the net magnetization at any given temperature is analogous to the excess of particles over antiparticles in the early Universe. The time evolution of this anisotropic to isotropic transition is modeled on the evolution of a statistical thermodynamics system with particles on a lattice placed in a magnetic field. The particles on the lattice are localized, static and have no mutual interaction. The free energy of the system is given by:

$$F = -Nk_B T \ln\{4 \cosh[m\beta]\}. \quad (9)$$

From this we can calculate the entropy S , heat capacity

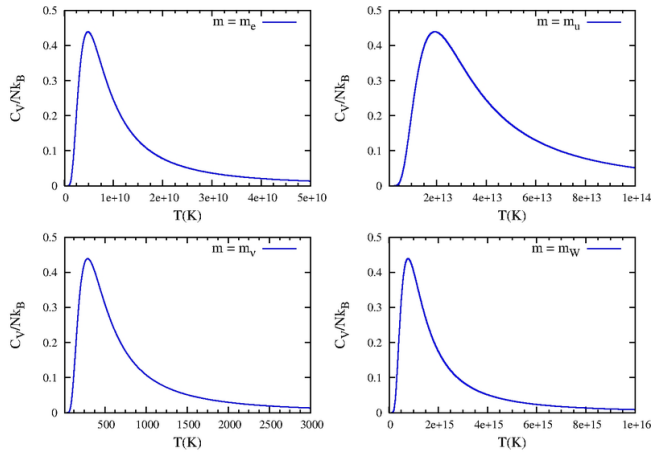

Fig. 1: Plot of heat capacity C_V for the mass of electron, up quark, neutrino and W boson. The maximum of the heat capacity of the electron occurs at 4.8×10^9 K, for the up quarks is 1.9×10^{13} K, for neutrinos is 291 K and for the W bosons is 7.8×10^{14} K. We use $k_B = 8.6 \times 10^{-5}$ eV/K and $m_\nu = 0.03$ eV.

C_V and mean energy U of the system:

$$S = -\left(\frac{\partial F}{\partial T}\right)_V = Nk_B \ln \{4 \cosh [m\beta]\} - Nm k_B \beta \tanh [m\beta] \quad (10)$$

$$U = F + TS = -Nm \tanh [m\beta] \quad (11)$$

$$C_V = \left(\frac{\partial U}{\partial T}\right)_V = Nk_B m^2 \beta^2 \operatorname{sech}^2 [m\beta] \quad (12)$$

In Fig. 1, the peaks in the heat capacity represent phase transition of a particular particle species. These are second order phase transitions and the peak in the heat capacity is usually referred to as the Schottky anomaly [5]. Note that the phase transition we model our system on is a magnetic one. So, modeling the complex system in the early Universe on a lattice with spin 1/2 particles can reduce the complications of the actual system by a considerable amount.

The Schottky anomaly of such a magnetic system, therefore, represents phase transitions in the early Universe. For a particular species of particles the Schottky anomaly shows a peak around $mc^2 \approx kT$. The phase transition for the electrons occurs at the temperature where nuclei start forming in the early Universe. For the quarks the transition temperature refers to confinement into protons and neutrons. Similarly, W boson's transition occurs at the electroweak breaking scale. The W boson, being a spin 1 particle, is not described by the Dirac equation, but the heat capacity entails this feature of showing a phase transition for the energy scale relevant to the mass of a particle.

The curve for neutrinos implies that the transition temperature for neutrinos is around 291 K, which means that the density of antineutrinos from the big bang for present

neutrino background temperatures (~ 2 K) is not negligible. The ratio of antineutrinos over neutrinos for $T = 2$ K, is $n_{\bar{\nu}}/n_\nu \sim 10^{-15000}$ ($m_\nu = 2$ eV) and for an even lower neutrino mass $m_\nu = 0.1$ eV the ratio is $n_{\bar{\nu}}/n_\nu \sim 10^{-500}$, which for other more massive particles is much smaller. A cosmic neutrino and antineutrino background is one of the predictions of standard cosmology but is still unobserved. This model predicts an antineutrino background much less than the neutrino one.

In Fig. 2, the plots of mean energy and entropy are shown in dimensionless units. In the massless limit for fermions the entropy attains its maximum value of $Nk_B \ln 4$. The plots show that the energy of the system approaches zero as the temperature approaches infinity. This situation is analogous to the spins being completely random at high temperatures for the two level system. The same way that the magnetic energy of the system on the lattice is zero at high temperatures, the mass of this system is zero in the very early Universe. As the temperature decreases the energy of the system attains its minimum value ($U = -Nm$) and the particles become massive at the temperature less than the value given by the peak of the heat capacity. The entropy for high temperatures asymptotically approaches its maximum value of $Nk_B \ln 4$.

According to the statistical thermodynamics model that describes this transition, as this phase transition occurs antiparticles will start changing into particles and as can be seen from the figure the system will move towards all spins aligned parallel with the "field", i.e., towards being particles. From Fig. 2 we can see that the energy of the system starts attaining the minimum value as the temperature decreases where all particles are aligned with the field and are "particles". The plot of entropy vs. temperature also represents an important feature of these transformations. The entropy decreases with decreasing temperature and this represents the transition to a more ordered phase using equations (2). The plots of energy of the system U in Fig. 2 show that the system will eventually settle down to the lowest energy state which in this case means that the system will have almost all particles with negligible number of antiparticles. In short, the plot of the heat capacity reflects the phase transitions, the plot of energy U represents the transition from massless to massive states and the plot of entropy represents the transition of space time to a more ordered phase.

The Big Bang theory is one of the most promising candidates to describe how the Universe began. According to this theory, the Universe expanded from a singularity where curved space-time, being locally Minkowskian, eventually became flat. It is possible that there even was a transition to the Minkowski space from a non-Minkowski one. If the Universe began with a state of maximum entropy than we can very well assume that space-time was not Minkowskian even locally. The fields that dwell in space-time are representation of the symmetry group that describes it. The χ fields in the underlying theory, described by equation (1), are therefore, not rep-

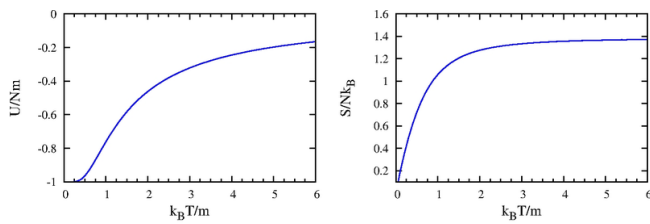

Fig. 2: Plot of entropy and energy for a particle of mass m . For large enough temperatures the energy of the system approaches zero and the entropy approaches the limiting value of $Nk_B \ln 4$.

representations of the Lorentz group. The CPT theorem assumes symmetries of Minkowski space-time in implying the similarities between particles and antiparticles. If the underlying theory is not Minkowskian than particles and antiparticles can behave differently and this is what the model described in this section implies.

Finally, we would like to point out that the occurrence of the Schottky anomaly has motivated the study of negative temperatures [6]. Note that the partition functions is invariant under the transformation $T \rightarrow -T$ but the equations for the free energy, entropy and energy are not. The existence of negative temperatures has been observed in experiments. Negative temperatures, for example, can be realized in a system of spins if the direction of the magnetic field is suddenly reversed for a system of spins initially aligned with the magnetic field [5]. Similarly, as described in reference [6] the allowed states of the system must have an upper limit. Whereas this is not the case for the actual particles in the early Universe, the statistical mechanics system on which it can be modeled on has this property. A negative temperature system would eventually settle down to the lower energy state ($U = Nm$) which in our case would mean that the Universe would end up having more antiparticles than particles. This is yet another interesting insight we get by modeling the early Universe on a two state system.

5 Conclusions

We analyzed transformations that restore the Dirac equation to its covariant form from an underlying theory that violates Lorentz invariance. The fields in the underlying theory are massless and the transformations yielding the Dirac equation describe a massive fermion field. The transformations performed, we suggest, can be interpreted as waves traveling in an anisotropic medium. The partition function formalism then, enabled us to model these transformations on the evolution of a system of spin 1/2 particles on a lattice placed in a magnetic field. Symmetry breaking in this case takes place in this lattice, the partition function of which characterizes the transition. Also, since space-time is not Minkowskian in the underlying theory, the CPT theorem does not hold, implying a difference in the behavior of particles and antiparticles. This

is in agreement with the analogy created with the statistical system whereby spin up and down particles behave in different ways with the evolution of the system. This formalism can arguably serve as another possible way to explain the origin of fermion masses till the final results related to the Higgs boson are presented in 2012.

We then showed that this model can describe the anisotropic to isotropic phase transitions in the early Universe. Three important features of the early Universe are depicted in this model: (1) The heat capacity shows the occurrence of phase transitions. (2) The mean energy of the system shows how the particles become massive from being massless. (3) The plot of entropy shows that the transition to a Lorentz symmetric phase occurred from an asymmetric one. At any given temperature the net magnetization measures the excess of particles over antiparticles. We then suggest that this model can be used to explain the matter antimatter asymmetry of the Universe.

Acknowledgements

I would like to thank Fariha Nasir, Hassnain Jaffari and Ilia Gogoladze for useful discussions and comments.

Submitted on January 24, 2012 / Accepted on February 4, 2012

References

1. Colladay D., Kostelecky V.A. Lorentz violating Extension of the Standard Model. *Physical Review D*, 1998, v. 58, 116002–116025.
2. Kostelecky V.A. and Russell N. Data Tables for Lorentz and CPT Violation. *Reviews in Modern Physics*, 2011, v. 83, 11–31.
3. Braga M.B. and Hermann G. Floquet waves in anisotropic periodically layered composites. *Journal of the Acoustical Society of America*, 1992, v. 91, 1211–1227.
4. Zee A. Quantum Field Theory in a Nutshell. Princeton University Press, Princeton, NJ, 2003.
5. Pathria R.K. Statistical Mechanics. Butterworth-Heinemann, Oxford, 1996; Greiner W. Thermodynamics and Statistical Mechanics. Springer, New York, 1995.
6. Ramsey N.F. Thermodynamics and Statistical Mechanics at Negative Absolute Temperatures. *Physical Review*, 1956, v. 103, 20–28.

Local Doppler Effect, Index of Refraction through the Earth Crust, PDF and the CNGS Neutrino Anomaly?

Armando V.D.B. Assis

Departamento de Física, Universidade Federal de Santa Catarina – UFSC, Trindade 88040-900, Florianópolis, SC, Brazil
E-mail: armando.assis@pgfsc.ufsc.br

In this brief paper, we show the neutrino velocity discrepancy obtained in the OPERA experiment may be due to the local Doppler effect between a local clock attached to a given detector at Gran Sasso, say C_G , and the respective instantaneous clock crossing C_G , say C_C , being this latter at rest in the instantaneous inertial frame having got the velocity of rotation of CERN about Earth's axis in relation to the fixed stars. With this effect, the index of refraction of the Earth crust may accomplish a refractive effect by which the neutrino velocity through the Earth crust turns out to be small in relation to the speed of light in the empty space, leading to an encrusted discrepancy that may have contaminated the data obtained from the block of detectors at Gran Sasso, leading to a time interval excess ϵ that did not provide an exact match between the shift of the protons PDF (probability distribution function) by TOF_c and the detection data at Gran Sasso via the maximum likelihood matching.

1 Definitions and Solution

Firstly, the effect investigated here is not the same one that was investigated in [2], but, throughout this paper, we will use some useful configurations defined in [2]. The relative velocity between Gran Sasso and CERN due to the Earth daily rotation may be written:

$$\vec{v}_G - \vec{v}_C = 2\omega R \sin \alpha \hat{e}_z, \quad (1)$$

where \hat{e}_z is a convenient unitary vector, the same used in [2], ω is the norm of the Earth angular velocity vector about its daily rotation axis, being R given by:

$$R_E = \frac{R}{\cos \lambda}, \quad (2)$$

where R_E is the radius of the Earth, its averaged value $R_E = 6.37 \times 10^6$ m, and α given by:

$$\alpha = \frac{1}{2}(\alpha_G - \alpha_C), \quad (3)$$

where α_C and α_G are, respectively, CERN's and Gran Sasso's longitudes ($\leftarrow WE \rightarrow$). Consider the inertial (in relation to the fixed stars) reference frame $O_C x_C y_C z_C \equiv Oxyz$ in [2]. This is the lab reference frame and consider this frame with its local clocks at each spatial position as being ideally synchronized, viz., under an ideal situation of synchronicity between the clocks of $O_C x_C y_C z_C \equiv Oxyz$. This situation is the expected ideal situation for the OPERA collaboration regarding synchronicity in the instantaneous lab (CERN) frame.

Now, consider an interaction between a single neutrino and a local detector at Gran Sasso. This event occurs at a given spacetime point $(t_\nu, x_\nu, y_\nu, z_\nu)$ in $O_C x_C y_C z_C \equiv Oxyz$. The interaction instant t_ν is measured by a local clock C_C at rest at (x_ν, y_ν, z_ν) in the lab frame, viz., in the $O_C x_C y_C z_C \equiv$

$Oxyz$ frame. But, under gedanken, at this instant t_ν , according to $O_C x_C y_C z_C \equiv Oxyz$, there is a clock C_G attached to the detector at Gran Sasso that crosses the point $(t_\nu, x_\nu, y_\nu, z_\nu)$ with velocity given by Eq. (1). Since C_G crosses C_C , the Doppler effect between the proper tic-tac rates measured at each location of C_C and C_G , viz., measured at their respective locations in their respective reference frames (the reference frame of C_G is the $O_G x_G y_G z_G \equiv \tilde{O}\tilde{x}\tilde{y}\tilde{z}$ in [2], also inertial in relation to the fixed stars), regarding a gedanken control tic-tac rate continuously sent by C_C , say via electromagnetic pulses from C_C , is not transverse. Since the points at which C_C and C_G are at rest in their respective reference frames will instantaneously coincide, better saying, will instantaneously intersect, at t_ν accordingly to C_C , they must be previously approximating, shortening their mutual distance during the interval $t_\nu - \delta t_\nu \ll t_\nu$ along the line passing through these clocks as described in the C_C world.

Suppose C_C sends N electromagnetic pulses to C_G . During the C_C proper time interval $(t_\nu - \delta t_\nu) - 0 = t_\nu - \delta t_\nu$ * within which C_C emits the N electromagnetic pulses, the first emitted pulse travels the distance $c(t_\nu - \delta t_\nu)$ and reaches the clock C_G , as described by C_C . Within this distance, there are N equally spaced distances between consecutive pulses as

*The initial instant C_C starts to emit the electromagnetic pulses is set to zero in both the frames $O_C x_C y_C z_C \equiv Oxyz$ and $O_G x_G y_G z_G \equiv \tilde{O}\tilde{x}\tilde{y}\tilde{z}$; zero also is the instant the neutrino starts the travel to Gran Sasso in $O_C x_C y_C z_C \equiv Oxyz$; hence the instant the neutrino starts the travel to Gran Sasso and the emission of the first pulse by C_C are simultaneous events in $O_C x_C y_C z_C \equiv Oxyz$. These events are simultaneous in $O_G x_G y_G z_G \equiv \tilde{O}\tilde{x}\tilde{y}\tilde{z}$ too, since they have got the same spatial coordinate $z_c = z = 0$ along the $O_C z_C \equiv O_z$ direction as defined in [2]. The relative motion between CERN and Gran Sasso is parallel to this direction. The only one difference between these events is the difference in their $x_C = x$ coordinates, being $x_C = 0$ for the neutrino departure and $x_C = L = 7.3 \times 10^5$ m for C_C , being these locations perpendicularly located in relation to the relative velocity given by the Eq. (1).

described in the C_C world, say λ_C :

$$N\lambda_C = c(t_v - \delta t_v). \quad (4)$$

Also, since the clocks C_C and C_G will intersect at t_v , as described in $O_C x_C y_C z_C \equiv Oxyz$, during the interval δt_v , the clock C_G must travel the distance $2\omega R \sin \alpha \delta t_v$ in the C_C world to accomplish the matching spatial intersection at the instant t_v , hence the clock C_G travels the $2\omega R \sin \alpha \delta t_v$ in the C_C world, viz., as described by C_C in $O_C x_C y_C z_C \equiv Oxyz$:

$$N\lambda_C = 2\omega R \sin \alpha \delta t_v \Rightarrow \delta t_v = N \frac{\lambda_C}{2\omega R \sin \alpha}. \quad (5)$$

Solving for t_v , from the Eqs. (4) and (5), one reaches:

$$t_v = \frac{N\lambda_C}{c} \left(1 + \frac{c}{2\omega R \sin \alpha} \right). \quad (6)$$

Now, from the perspective of C_G , in $O_G x_G y_G z_G \equiv \tilde{O}\tilde{x}\tilde{y}\tilde{z}$, there must be N electromagnetic pulses covering the distance:

$$c(t_v^G - \delta t_v^G) - 2\omega R \sin \alpha (t_v^G - \delta t_v^G), \quad (7)$$

where $t_v^G - \delta t_v^G$ is the time interval between the non-proper instants $t_v^G = t_v = 0$, at which the C_C clock sends the first pulse, and the instant $t_v^G - \delta t_v^G$, at which this first pulse reaches C_G , as described by C_G in its world $O_G x_G y_G z_G \equiv \tilde{O}\tilde{x}\tilde{y}\tilde{z}$. Within this time interval, $t_v^G - \delta t_v^G$, C_G describes, in its $O_G x_G y_G z_G \equiv \tilde{O}\tilde{x}\tilde{y}\tilde{z}$ world, the clock C_C approximating the distance:

$$2\omega R \sin \alpha (t_v^G - \delta t_v^G), \quad (8)$$

with the first pulse traveling:

$$c(t_v^G - \delta t_v^G), \quad (9)$$

giving the distance within which there must be N equally spaced pulses, say, spaced by λ_G , as described by C_G in its $O_G x_G y_G z_G \equiv \tilde{O}\tilde{x}\tilde{y}\tilde{z}$ world:

$$N\lambda_G = (c - 2\omega R \sin \alpha)(t_v^G - \delta t_v^G). \quad (10)$$

With similar reasoning that led to the Eq. (5), now in the $O_G x_G y_G z_G \equiv \tilde{O}\tilde{x}\tilde{y}\tilde{z}$ C_G world, prior to the spatial matching intersection between C_C and C_G , the C_C clock must travel the distance $N\lambda_G$ during the time interval δt_v^G , with the C_C approximation velocity $2\omega R \sin \alpha$:

$$N\lambda_G = 2\omega R \sin \alpha \delta t_v^G \Rightarrow \delta t_v^G = N \frac{\lambda_G}{2\omega R \sin \alpha}. \quad (11)$$

From Eqs. (10) and (11), we solve for t_v^G :

$$t_v^G = N \frac{\lambda_G}{2\omega R \sin \alpha} \frac{1}{[1 - (2\omega R \sin \alpha)/c]}. \quad (12)$$

From the Eqs. (6) and (12), we have got the relation between the neutrino arrival instant t_v , as measured by the CERN reference frame, $O_C x_C y_C z_C \equiv Oxyz$, and the neutrino arrival instant t_v^G as measured by the Gran Sasso reference frame, $O_G x_G y_G z_G \equiv \tilde{O}\tilde{x}\tilde{y}\tilde{z}$, at the exact location of the interaction at an interaction location within the Gran Sasso block of detectors, provided the effect of the Earth daily rotation under the assumptions we are taking in relation to the instantaneous movements of these locations in relation to the fixed stars as previously discussed:

$$\frac{t_v^G}{t_v} = \frac{\lambda_G}{\lambda_C} [1 - (2\omega R \sin \alpha)^2 / c^2]^{-1} = \gamma^2 \frac{\lambda_G}{\lambda_C}, \quad (13)$$

where $\gamma \geq 1$ is the usual relativity factor as defined above.

Now, λ_G/λ_C is simply the ratio between the spatial displacement between our consecutive gedanken control pulses, being these displacements defined through our previous paragraphs, leading to the Eqs. (4) and (10). Of course, this ratio is simply given by the relativistic Doppler effect under an approximation case in which C_C is the source and C_G the detector. The ratio between the Eqs. (10) and (4) gives:

$$\frac{\lambda_G}{\lambda_C} = [1 - (2\omega R \sin \alpha)/c] \frac{(t_v^G - \delta t_v^G)}{(t_v - \delta t_v)}. \quad (14)$$

But the time interval $(t_v - \delta t_v)$ is a proper time interval measured by the source clock C_C , as previously discussed. It accounts for the time interval between the first pulse sent and the last pulse sent as locally described by C_C in its $O_C x_C y_C z_C \equiv Oxyz$ world. These two events occur at different spatial locations in the C_G detector clock world $O_G x_G y_G z_G \equiv \tilde{O}\tilde{x}\tilde{y}\tilde{z}$, since C_C is approximating to C_G in this latter world. Hence, $t_v - \delta t_v$ is the Lorentz time contraction of $t_v^G - \delta t_v^G$, viz.:

$$t_v - \delta t_v = \gamma^{-1} (t_v^G - \delta t_v^G) \quad .$$

$$\frac{(t_v^G - \delta t_v^G)}{t_v - \delta t_v} = \gamma = [1 - (2\omega R \sin \alpha)^2 / c^2]^{-1/2}. \quad (15)$$

With the Eqs. (14) and (15), one reaches the usual relativistic Doppler effect expression for the approximation case:

$$\frac{\lambda_G}{\lambda_C} = \sqrt{\frac{1 - (2\omega R \sin \alpha)/c}{1 + (2\omega R \sin \alpha)/c}}. \quad (16)$$

With the Eq. (16), the Eq. (13) reads:

$$\begin{aligned} \frac{t_v^G}{t_v} &= [1 - (2\omega R \sin \alpha)^2 / c^2]^{-1/2} [1 + (2\omega R \sin \alpha)/c]^{-1} = \\ &= \frac{\gamma}{1 + (2\omega R \sin \alpha)/c}. \end{aligned} \quad (17)$$

Since $(2\omega R \sin \alpha)/c \ll 1$, we may apply an approximation for the Eq. (17), viz.:

$$\gamma \approx 1 + \frac{1}{2} \frac{(2\omega R \sin \alpha)^2}{c^2}, \quad (18)$$

and:

$$[1 + (2\omega R \sin \alpha) / c]^{-1} \approx 1 - (2\omega R \sin \alpha) / c, \quad (19)$$

from which, neglecting the higher order terms, the Eq. (17) reads:

$$\frac{t_v^G}{t_v} \approx 1 - \frac{2\omega R \sin \alpha}{c} \quad \therefore \quad (20)$$

$$t_v^G - t_v = -\frac{2\omega R \sin \alpha}{c} t_v. \quad (21)$$

From this result, the clock that tag the arrival interaction instant t_v^G in Gran Sasso turns out to measure an arrival time that is shorter than the correct one, this latter given by t_v . With the discrepancy, ϵ , given by the value measured by the OPERA Collaboration [1], since t_v is simply given by L/v_ν , where L is the baseline distance between the CERN and Gran Sasso, v_ν the speed of neutrino through the Earth crust, one obtains a value for v_ν . We rewrite the Eq. (21):

$$\epsilon = t_v^G - t_v = -\frac{2\omega R \sin \alpha}{c} \frac{L}{v_\nu}. \quad (22)$$

With the values* $\omega = 7.3 \times 10^{-5} \text{ s}^{-1}$, $R = R_E \cos \lambda \approx 6.4 \times 10^6 \text{ m} \times \cos(\pi/4) = 4.5 \times 10^6 \text{ m}$, $\sin \alpha \approx \sin(7\pi/180) = 1.2 \times 10^{-1}$, $c = 3.0 \times 10^8 \text{ ms}^{-1}$ and $L = 7.3 \times 10^5 \text{ m}$, also with the discrepancy ϵ , given by the Eq. (22), being, say, $\epsilon = -62 \times 10^{-9} \text{ s}$, the neutrino velocity through the Earth crust reads:

$$v_\nu \approx 3.1 \times 10^6 \text{ ms}^{-1}, \quad (23)$$

being the refraction index of the Earth crust for neutrino given by:

$$n_{c|\nu} = \frac{c}{v_\nu} \approx 97. \quad (24)$$

In reference to the matching PDF (probability distribution function) in the OPERA experiment, one would have a discrepancy between the maximum likelihood distribution obtained from the block of detectors at Gran Sasso and the translation of the PDF due to the protons distribution by TOF_c given by, in virtue of the Eq. (22):

$$\text{TOF}_\nu = \text{TOF}_c + \epsilon = \text{TOF}_c - \frac{2\omega R \sin \alpha}{c} \frac{L}{v_\nu} \quad \therefore$$

$$\text{TOF}_\nu - \text{TOF}_c \approx -62 \text{ ns}, \quad (25)$$

under the reasoning and simplifications throughout this paper. One should notice the reasoning here holds if the discrepancy turns out to be encrusted within the time translation of the PDF data, but such effect would not arise if the time interval TOF_ν were directly measured, since, in this latter situation, such interval would only read L/v_ν .

*See the Eqs. (2) and (3). The latitudes of CERN and Gran Sasso are, respectively: $46^{\text{deg}}14^{\text{min}}3^{\text{sec}}(\text{N})$ and $42^{\text{deg}}28^{\text{min}}12^{\text{sec}}(\text{N})$. The longitudes of CERN and Gran Sasso are, respectively: $6^{\text{deg}}3^{\text{min}}19^{\text{sec}}(\text{E})$ and $13^{\text{deg}}33^{\text{min}}0^{\text{sec}}(\text{E})$.

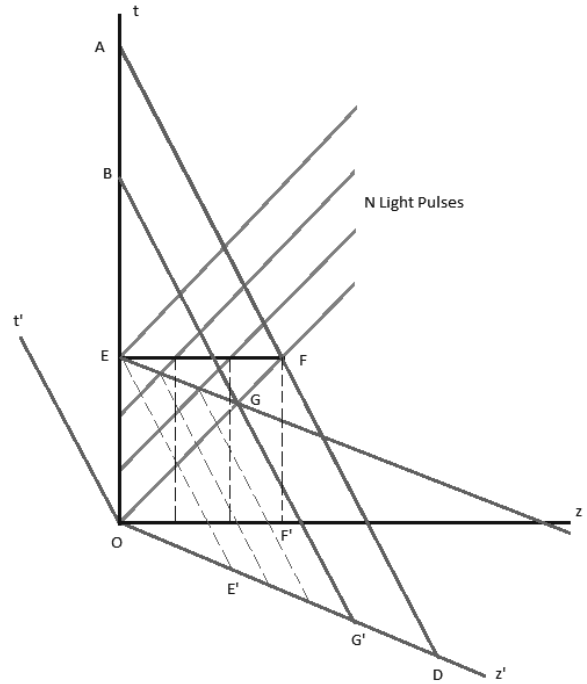

Fig. 1: Spacetime diagram for the phenomenon previously discussed. The Oz and Oz' axes depict the negative portions, respectively, of our previously defined Oz and $\tilde{O}z$ axes.

2 Spacetime diagram: a detailed explanation

Fig. 1 depicts the results we previously obtained, to which we will provide interpretation throughout this section.

The method we had used as a gedankenexperiment to send N light pulses is depicted via the Fig. 1. There are two different situations, since we want to determine, via the application of N gedanken pulses, in which reference frame the interaction of a neutrino at a point within the block of detectors at Gran Sasso actually had its interaction instant tagged. One should notice the Opera Collaboration shifted the PDF of the protons distribution to the time location of the interactions at Gran Sasso, but one must notice the proton PDF was not at the same instantaneous reference frame the block of detectors was. Hence, when one shifts the proton PDF distribution, one is assuming this shifted distribution represents the interactions at Gran Sasso in the same reference frame of the produced protons. This latter situation of shifting the PDF data of the protons is represented by the point A in the Fig. 1, viz., the point A represents the protons PDF distribution at its shifted position, and the clock that measures the shifting process is at rest in the CERN reference frame previously discussed, $O_C x_C y_C z_C \equiv Oxyz$, being our previously obtained t_v given by the line segment OA in the Fig. 1, with the method of N sent pulses firstly accomplished in this reference frame. Note that $t_\nu \equiv OA$ is not the time a photon

would spend to accomplish the shift *, since one would expect this from the shifting the OPERA Collaboration statistically accomplished, once the Collaboration would be intrinsically assuming the time shift TOF_c as actually being the time interval the protons PDF would spend to match the distribution at the detection location, which would lead to a neutral shift in comparison with the detected distribution obtained from the Gran Sasso detectors in a case in which the protons PDF travelled at c , viz., a fortuitous shift would be simply pointing out to a velocity discrepancy in relation to c . The time interval the protons PDF actually spent to reach the Gran Sasso detectors was not directly measured, and the physical shift that actually occurred was, by the reasonings of this paper, t_ν . Now, since the interactions at Gran Sasso occurred in the $O_Gx_Gy_Gz_G \equiv \tilde{O}\tilde{x}\tilde{y}\tilde{z}$ reference frame, the clock that tagged a neutrino interaction, measured via our gedanken method of \mathcal{N} sent pulses, now being applied in the Gran Sasso reference frame, has its world line $G'B$ in the Fig. 1, viz, $t_\nu^G \equiv G'B$, i.e., the line segment $G'B$ in the Fig. 1 has our previously obtained t_ν^G as its length. Hence, once the OPERA Collaboration tried to match t_ν and t_ν^G , they, unfortunately, would obtain a discrepancy given by the Eq. (22), since two *different* frames raise and do not match. Finally, we would like to point out that, in the Fig. 1: OE is our previously defined $t_\nu - \delta t_\nu$, EA is our previously defined δt_ν , $G'G$ is our previously defined $t_\nu^G - \delta t_\nu^G$ and GB is our previously defined δt_ν^G . Also, as said before, A is the time location the proton PDF was actually shifted by the OPERA Collaboration, although they had a priori assumed a TOF_c shift for the protons PDF, and B the time location a Gran Sasso local clock actually tagged a neutrino event.

3 Conclusion

It is interesting to observe that even with a velocity having got two orders of magnitude lesser than c a neutrino may be interpreted as having got a velocity greater than c , depending on the method used to measure neutrino's time of flight, with the Earth crust presenting an index of refraction $n_{cl\nu} > 1$, due, also, to the local Doppler effect between the clocks attached to Gran Sasso and the respective intersecting ones in the CERN reference frame, as discussed throughout this paper, in virtue of the Earth daily rotation.

Acknowledgments

A.V.D.B. A. is grateful to Y.H.V.H. and CNPq for financial support.

Submitted on February 11, 2012 / Accepted on February 12, 2012

*the propagation axis of this photon does not appear in Fig. 1, since its propagation axis, Ox , is not depicted in the Fig. 1, which is not relevant for our analysis here. This same irrelevance for the propagation axis of the neutrinos holds here.

References

1. The OPERA collaboration: Adam T. et al. Measurement of the neutrino velocity with the OPERA detector in the CNGS beam. *arXiv:1109.4897*, 2011 (<http://arxiv.org/abs/1109.4897>).
2. Assis A.V.D.B. On the Neutrino Opera in the CNGS Beam. *Progress in Physics*, 2011, v. 4, 85–90.

A Way to Revised Quantum Electrodynamics

Bo Lehnert

Alfvén Laboratory, Royal Institute of Technology, 10044 Stockholm, Sweden
E-mail: Bo.Lehnert@ee.kth.se

In conventional theoretical physics and its Standard Model the guiding principle is that the equations are symmetrical. This limitation leads to a number of difficulties, because it does not permit masses for leptons and quarks, the electron tends to “explode” under the action of its self-charge, a corresponding photon model has no spin, and such a model cannot account for the “needle radiation” proposed by Einstein and observed in the photoelectric effect and in two-slit experiments. This paper summarizes a revised Lorentz and gauge invariant quantum electrodynamic theory based on a nonzero electric field divergence in the vacuum and characterized by linear intrinsic broken symmetry. It thus provides an alternative to the Higgs concept of nonlinear spontaneous broken symmetry, for solving the difficulties of the Standard Model. New results are obtained, such as nonzero and finite lepton rest masses, a point-charge-like behavior of the electron due to a revised renormalization procedure, a magnetic volume force which counteracts the electrostatic eigen-force of the electron, a nonzero spin of the photon and of light beams, needle radiation, and an improved understanding of the photoelectric effect, two-slit experiments, electron-positron pair formation, and cork-screw-shaped light beams.

1 Introduction

Conventional electromagnetic theory based on Maxwell’s equations and quantum mechanics has been successful in its applications to numerous problems in physics, and has sometimes manifested itself in an extremely good agreement with experiments. Nevertheless there exist areas within which these joint theories do not provide fully adequate descriptions of physical reality. As already stated by Feynman [1], there are unsolved problems leading to difficulties with Maxwell’s equations that are not removed by and not directly associated with quantum mechanics. It has thus to be remembered that these equations have served as a guideline and basis for the development of quantum electrodynamics (QED) in the vacuum state. Therefore QED also becomes subject to the typical shortcomings of electromagnetics in its conventional form.

A way to revised quantum electrodynamics is described in this paper, having a background in the concept of a vacuum that is not merely an empty space. There is thus a nonzero level of the vacuum ground state, the zero point energy, which derives from the quantum mechanical energy states of the harmonic oscillator. Part of the associated quantum fluctuations are also carrying electric charge. The observed electron-positron pair formation from an energetic photon presents a further indication that electric charges can be created out of an electrically neutral vacuum state. In this way the present approach becomes based on the hypothesis of a nonzero electric charge density and an associated electric field divergence in the vacuum state. This nonzero divergence should not become less conceivable than the nonzero curl of the magnetic field related to Maxwell’s displacement current.

The present treatise starts in Section 2 with a discussion on quantization of the field equations. This is followed in

Section 3 by a description of the difficulties which remain in conventional theory and its associated Standard Model. An outline of the present revised theory is then given in Section 4, and its potentialities are presented in Section 5. A number of fundamental applications and new consequences of the same theory are finally summarized in Sections 6 and 7.

2 Quantization of the field equations

As stated by Schiff [2] among others, Maxwell’s equations are used as a guideline for proper interpretation of conventional quantum electrodynamical theory. To convert in an analogous way the present extended field equations into their quantum electrodynamical counterpart, the most complete way would imply that the quantum conditions are included already from the outset.

In this treatise, however, a simplified procedure is applied, by first determining the general solutions of the basic field equations, and then imposing the relevant quantum conditions afterwards. This is at least justified by the fact that the quantized electrodynamic equations become identically equal to the original equations in which the potentials and currents are merely replaced by their expectation values, as shown by Heitler [3]. The result of such a procedure should therefore not be too far from the truth, by using the most probable trajectories and states in a first approximation.

3 Difficulties in conventional theory

As pointed out by Quigg [4] among others, the guiding principle of the Standard Model in theoretical physics is that its equations are symmetrical, and this does not permit masses for leptons and quarks. Such a feature also reveals itself in the symmetry of the conventional field equations of QED in

which there are vanishing divergences of both the electric and magnetic fields in the vacuum, as given e.g. by Schiff [2].

In the Dirac wave equation of a single particle like the electron, the problem of nonzero mass and charge is circumvented by introducing given values of its mass m_e and charge e . With an electrostatic potential ϕ and a magnetic vector potential \mathbf{A} , the equation for the relativistic wave function has the form

$$\alpha_0 m_e c \Psi + \alpha \cdot [(\hbar/i)\nabla\Psi - (e/c)\mathbf{A}\Psi] + e\phi\Psi = -\frac{\hbar}{ic} \frac{\partial}{\partial t} \Psi \quad (1)$$

where α_i are the Dirac matrices given e.g. by Morse and Feshbach [5].

To fulfill the demand of a nonzero particle mass, the symmetry of the field equations has to be *broken*. One such possibility was worked out in the mid 1960s by Higgs [6] among others. From the corresponding equations a Higgs particle was predicted which should have a nonzero rest mass. Due to Ryder [7] the corresponding Lagrangian then takes the form

$$\mathcal{L} = -\frac{1}{4} F_{\mu\nu} F^{\mu\nu} + \left| (\partial_\mu + icA_\mu) \phi \right|^2 - m^2 \phi^* \phi - \lambda (\phi^* \phi)^2 \quad (2)$$

where ϕ represents a scalar field, A_μ a vector field, and $F_{\mu\nu} = \partial_\mu A_\nu - \partial_\nu A_\mu$ is the electromagnetic field tensor. The quantity m further stands for a parameter where $m^2 < 0$ in the case of *spontaneous symmetry breaking*, and the parameter λ is related to a minimized potential. The symmetry breaking is due to the two last terms of the Lagrangian (2). The latter is *nonlinear* in its character, and corresponds to a deduced relation for the minimum of the vacuum potential. Experimental confirmation of this mechanism does not rule out the applicability of the present theory to the problem areas treated in this paper.

3.1 Steady states

Conventional theory based on Maxwell's equations in the vacuum is symmetric in respect to the field strengths \mathbf{E} and \mathbf{B} . In the absence of external sources, such as for a self-consistent particle-like configuration, the charge density $\bar{\rho}$, $\text{div}\mathbf{E}$ and $\text{curl}\mathbf{B}$ all vanish. Then there is no scope for a local nonzero energy density in a steady state which would otherwise be the condition for a particle configuration having a nonzero rest mass. This is consistent with the statement by Quigg [4] that the symmetric conventional field equations do not permit masses for leptons and quarks.

The fundamental description of a charged particle is in conventional theory deficient also in the respect that an equilibrium cannot be maintained by the classical electrostatic forces, but has been assumed to require extra forces of a non-electromagnetic origin, as proposed e.g. by Heitler [3] and Jackson [8]. In other words, the electron would otherwise "explode" under the action of its electric self-charge.

The electron behaves like a point charge with a very small radius. Standard theory is confronted with the infinite self-energy of such a system. A quantum electromagnetic renormalization procedure has then been applied to yield a finite result, by adding an infinite ad hoc term to the Lagrangian, such as to obtain a finite result from the difference between two "infinities" [7]. Even if such a procedure has turned out to be successful, it can be questioned from the logical and physical points of view.

3.2 Wave modes

In a state of explicit time dependence, the conventional symmetric wave equations by Maxwell in the vacuum with vanishing electric and magnetic field divergences can be recast in terms of a Hertz vector $\mathbf{\Pi}$, as described by Stratton [9] and Halln [10] among others. These equations result in two partial solutions, $\mathbf{\Pi}_1$ and $\mathbf{\Pi}_2$, denoted as an electric and a magnetic type which are given by the fields

$$\mathbf{E}_1 = \nabla(\text{div}\mathbf{\Pi}_1) - (1/c^2)\partial^2\mathbf{\Pi}_1/\partial t^2 \quad (3)$$

$$\mathbf{B}_1 = (1/c^2)\text{curl}(\partial\mathbf{\Pi}_1/\partial t) \quad (4)$$

and

$$\mathbf{E}_2 = -\mu_0\text{curl}(\partial\mathbf{\Pi}_2/\partial t) \quad (5)$$

$$\mathbf{B}_2 = \mu_0\nabla(\text{div}\mathbf{\Pi}_2) - (\mu_0/c^2)\partial^2\mathbf{\Pi}_2/\partial t^2. \quad (6)$$

Here $c^2 = 1/\mu_0\epsilon_0$ with μ_0 denoting the magnetic permeability and ϵ_0 the dielectric constant in the vacuum. Using the results obtained from equations (3)-(6) and given in current literature, the integrated angular momentum in the direction of propagation (spin) can be evaluated for plane, cylindrical, and spherical wave modes. This is made in terms of the electromagnetic momentum density

$$\mathbf{g} = \epsilon_0\mathbf{E} \times \mathbf{B} = \frac{1}{c^2}\mathbf{S} \quad (7)$$

where \mathbf{S} is the Poynting vector, and of the density

$$\mathbf{s} = \mathbf{r} \times \frac{\mathbf{S}}{c^2} \quad (8)$$

with \mathbf{r} standing for the radius vector. The results are summarized as described by the author [11]:

- For plane waves propagating in the direction of a rectangular frame (x, y, z) the field components E_z and B_z vanish as well as the spin. A three-dimensional disturbance of arbitrary shape at a given instant can in principle be constructed by Fourier analysis from a spectrum of plane waves. At later instants, however, such a disturbance would rapidly disintegrate [9].
- Cylindrical geometry has the advantage of providing a starting point for waves which propagate with conserved shape in a defined direction like a photon, at

the same time as it can have limited dimensions in the transverse directions under certain conditions. With an elementary wave form $f(r) \exp[i(-\omega t + kz + n\varphi)]$ in a cylindrical frame (r, φ, z) with z in the direction of propagation, the dispersion relation becomes

$$K^2 = (\omega/c)^2 - k^2 \quad (9)$$

This leads to local spin densities s_{z1} and s_{z2} of equation (8) in respect to the z axis where

$$|s_{z1}| \text{ and } |s_{z2}| \propto K^2 n [J_n(Kr)]^2 \sin 2n\varphi \quad (10)$$

for the two types of equations (3)-(6), and with $J_n(Kr)$ as Bessel functions. Consequently, the local contribution to the spin vanishes both when $n = 0$ and $K = 0$. With nonzero n and K the total integrated spin also vanishes.

- When considering spherical waves which propagate along r in a spherical frame (r, θ, φ) of unbounded space at the phase velocity $\omega/k = c$ with a periodic variation $\exp(in\varphi)$, the field components are obtained in terms of associated Legendre functions, spherical Bessel functions, and factors $\sin(n\varphi)$ and $\cos(n\varphi)$ [9]. The asymptotic behavior of the components of the momentum density (7) then becomes

$$g_r \propto 1/r^2 \quad g_\theta \propto 1/r^3 \quad g_\varphi \propto 1/r^3 \quad (11)$$

The momentum g_r along the direction of propagation is the remaining one at large distances r for which the spin thus vanishes. From the conservation of angular momentum there is then no integrated spin in the near-field region as well. This is confirmed by its total integrated value.

From these results is thus shown that the conventional symmetric equations by Maxwell in the vacuum, and the related equations in quantized field theory, do not become reconcilable with a physically relevant photon model having nonzero spin.

In addition, a conventional theoretical concept of the photon as given by equations (3)-(6) cannot account for the needle-like behavior proposed by Einstein and being required for knocking out an atomic electron in the photoelectric effect. Nor can such a concept become reconcilable with the dot-shaped marks which occur at the screen of two-slit experiments from individual photon impacts, as observed e.g. by Tsuchiya et al. [12].

4 An outline of present revised theory

As stated in the introduction, the present theory is based on the hypothesis of a nonzero electric charge density in the vacuum. The detailed evaluation of the basic concepts of this theory has been reported by the author [13, 14] and is shortly outlined here. The general four-dimensional Lorentz invariant

form of the corresponding Proca-type field equations reads

$$\left(\frac{1}{c^2} \frac{\partial^2}{\partial t^2} - \nabla^2\right) A_\mu = \mu_0 J_\mu, \quad \mu = 1, 2, 3, 4 \quad (12)$$

where

$$A_\mu = \left(\mathbf{A}, \frac{i\phi}{c}\right) \quad (13)$$

with \mathbf{A} and ϕ standing for the magnetic vector potential and the electrostatic potential in three-space,

$$J_\mu = (\mathbf{j}, ic\bar{\rho}) = \bar{\rho}(\mathbf{C}, ic) \quad \mathbf{j} = \bar{\rho}\mathbf{C} = \epsilon_0(\text{div}\mathbf{E})\mathbf{C} \quad (14)$$

and \mathbf{C} being a velocity vector having a modulus equal to the velocity constant c of light, i.e. $\mathbf{C}^2 = c^2$. Consequently this becomes a *generalization* of Einsteins relativistic velocity limit. In three dimensions equation (12) in the vacuum results in

$$\frac{\text{curl}\mathbf{B}}{\mu_0} = \epsilon_0(\text{div}\mathbf{E})\mathbf{C} + \frac{\epsilon_0\partial\mathbf{E}}{\partial t} \quad (15)$$

$$\text{curl}\mathbf{E} = -\frac{\partial\mathbf{B}}{\partial t} \quad (16)$$

$$\mathbf{B} = \text{curl}\mathbf{A}, \quad \text{div}\mathbf{B} = 0 \quad (17)$$

$$\mathbf{E} = -\nabla\phi - \frac{\partial\mathbf{A}}{\partial t} \quad (18)$$

$$\text{div}\mathbf{E} = \frac{\bar{\rho}}{\epsilon_0}. \quad (19)$$

These equations differ from the conventional form, by a nonzero electric field divergence in equation (19) and by the additional first term of the right-hand member in equation (15) which represents a “space-charge current density” in addition to the displacement current. Due to the form (14) there is a similarity between the current density and that by Dirac [5]. The extended field equations (15)-(19) are easily found also to become invariant to a gauge transformation. The same equations can further be derived from a Lagrangian density

$$\mathcal{L} = \frac{1}{2}\epsilon_0(\mathbf{E}^2 - c^2\mathbf{B}^2) - \bar{\rho}\phi + \mathbf{j} \cdot \mathbf{A}. \quad (20)$$

In this context special attention will be paid to steady states for which the field equations reduce to

$$c^2 \text{curl}\text{curl}\mathbf{A} = -\mathbf{C}(\nabla^2\phi) = \frac{\bar{\rho}}{\epsilon_0}\mathbf{C} \quad (21)$$

and to wave modes for which

$$\left(\frac{\partial^2}{\partial t^2} - c^2\nabla^2\right)\mathbf{E} + \left(c^2\nabla + \mathbf{C}\frac{\partial}{\partial t}\right)(\text{div}\mathbf{E}) = 0. \quad (22)$$

The main characteristic new features of the present theory can be summarized as follows:

- The hypothesis of a nonzero electric field divergence in the vacuum introduces an *additional* degree of freedom, leading to new physical phenomena. The associated nonzero electric charge density thereby acts somewhat like a “hidden variable”.
- This also abolishes the symmetry between the electric and magnetic fields, and the field equations then obtain the character of *intrinsic linear symmetry breaking*.
- The theory is both Lorentz and gauge *invariant*.
- The velocity of light is no longer a scalar quantity, but is represented by a velocity *vector* of the modulus c .

5 Potentialities of present theory

Maxwell’s equations in the vacuum, and their quantized counterparts, are heavily constrained. Considerable parts of this limitation can be removed by the present theory. Thus the characteristic features described in Section 4 debouch into a number of potentialities:

- The present linear field equations are characterized by an intrinsic broken symmetry. The Lagrangian (20) differs from the form (2) by Higgs. The present approach can therefore become an *alternative* to the Higgs concept of nonlinear spontaneous broken symmetry.
- In the theory by Dirac the mass and electric charge of the electron have been introduced as given parameters in the wave equation (1), whereas nonzero and finite masses and charges *result* from the solutions of the present field equations. This is due to the symmetry breaking of these equations which include *steady* electromagnetic states, not being present in conventional theory.
- As a further consequence of this symmetry breaking, the electromagnetic wave solutions result in photon models having *nonzero* angular momentum (spin), not being deducible from conventional theory, and being due to the current density \mathbf{j} in equations (14) and (15) which gives a contribution to the momentum density (7).
- This broken symmetry also renders possible a *revised* renormalization process, providing an alternative to the conventional one in a physically more surveyable way of solving the infinite self-energy problem. This alternative is based on the nonzero charge density of equation (19).
- In analogy with conventional theory, a local momentum equation including a volume force term is obtained from vector multiplication of equation (15) by \mathbf{B} and equation (16) by $\epsilon_0\mathbf{E}$, and adding the obtained equations. This results in a volume force density which does not only include the well-known electrostatic part $\bar{\rho}\mathbf{E}$, but also a *magnetic* part $\bar{\rho}\mathbf{C} \times \mathbf{B}$ not being present in conventional theory.

6 Fundamental applications

A number of concrete results are obtained from the present theory, as fundamental applications to models of leptons and photons and to be shortly summarized in this section.

6.1 An Electron Model

Aiming at a model of the electron at rest, a steady axisymmetric state is considered in a spherical frame (r, θ, φ) where $\mathbf{A} = (0, 0, A)$ and $\mathbf{j} = (0, 0, c\bar{\rho})$ with $C = \pm c$ representing the two spin directions. Equations (21) can be shown to have a general solution being derivable from a separable generating function

$$F(r, \theta) = CA - \phi = G_0G(\rho, \theta) = G_0R(\rho)T(\theta) \quad (23)$$

where G_0 stands for a characteristic amplitude, $\rho = r/r_0$ is a normalized radial coordinate, and r_0 is a characteristic radial dimension. The potentials \mathbf{A} and ϕ as well as the charge density $\bar{\rho}$ can be uniquely expressed in terms of F and its derivatives. This, in its turn, results in forms for the spatially integrated net values of electric charge q_0 , magnetic moment M_0 , mass m_0 obtained from the mass-energy relation by Einstein, and spin s_0 .

A detailed analysis of the integrals of q_0 and M_0 shows that an electron model having nonzero q_0 and M_0 only becomes possible for radial functions $R(\rho)$ being divergent at the origin $\rho = 0$, in combination with a polar function $T(\theta)$ having top-bottom symmetry with respect to the midplane $\theta = \pi/2$. Neutrino models with vanishing q_0 and M_0 become on the other hand possible in three other cases. The observed point-charge-like behavior of the electron thus comes out as a consequence of the present theory, due to the requirement of a nonzero net electric charge.

The necessary divergence of the radial function R leads to the question how to obtain finite and nonzero values of all related field quantities. This problem can be solved in terms of a revised renormalization procedure, being an alternative to the conventional process of tackling the self-energy problem. Here we consider a generating function with the parts

$$R = \rho^{-\gamma} e^{-\rho}, \quad \gamma > 0 \quad (24)$$

$$\begin{aligned} T &= 1 + \sum_{\nu=1}^n \{a_{2\nu-1} \sin[(2\nu-1)\theta] + a_{2\nu} \cos(2\nu\theta)\} \\ &= 1 + a_1 \sin \theta + a_2 \cos 2\theta + a_3 \sin 3\theta + \dots \end{aligned} \quad (25)$$

where R is divergent at $\rho = 0$ and T is symmetric in respect to $\theta = \pi/2$. In the present renormalization procedure the lower radial limits of the integrals in (q_0, M_0, m_0, s_0) are taken to be $\rho = \epsilon$ where $0 < \epsilon \ll 1$. Further the concepts of first and second counter-factors are introduced and defined by the author [13,15], i.e.

$$f_1 = c_{rG}\epsilon = r_0G_0 \quad f_2 = c_G\epsilon^2 = G_0 \quad (26)$$

where c_{rG} and c_G are corresponding constants. Consequently all field quantities (q_0, M_0, m_0, s_0) then become nonzero and finite at small ϵ . This revised renormalization procedure implies that the “infinities” of the field quantities due to the divergence of R at $\rho = 0$ are outbalanced by the “zeros” of the counter-factors f_1 and f_2 .

The quantum conditions to be imposed on the general solutions are the spin condition

$$s_0 = \pm h/4\pi \quad (27)$$

of a fermion particle, the magnetic moment relation

$$M_0 m_0 / q_0 s_0 = 1 + \delta_M \quad \delta_M = 1/2\pi f_0 = 0.00116 \quad (28)$$

given e.g. by Feynman [16], and the magnetic flux condition

$$\Gamma_{tot} = |s_0/q_0| \quad (29)$$

where Γ_{tot} stands for the total magnetic flux being generated by the electric current system.

From these conditions the normalized electric charge $q^* \equiv |q_0/e|$, with $q^* = 1$ as its experimental value, can be obtained in terms of the expansion (25). In the four-amplitude case (a_1, a_2, a_3, a_4) the normalized charge q^* is then found to be limited at large a_3 and a_4 in the $a_3 a_4$ -plane to a narrow “plateau-like” channel, localized around the experimental value $q^* = 1$ as shown by Lehnert and Scheffel [17] and Lehnert and Hk [18]. As final results of these deductions all quantum conditions and all experimentally relevant values of charge, magnetic moment, mass, and spin can thus be reproduced by the single choices of only two scalar free parameters, i.e. the counter-factors f_1 and f_2 [15,17,18]. This theory should also apply to the muon and tauon and corresponding antiparticles.

With correct values of the magnetic flux (29) including magnetic island formation, as well as the correct magnetic moment relation (28) including its Land factor, the plateau in $a_3 a_4$ -space thus contains the correct experimental value $q^* = 1$ of the elementary charge. There are deviations of only a few percent from this value within the plateau region. This could at a first sight merely be considered as fortunate coincidence. What speaks against this is, however, that changes in the basic conditions result in normalized charges which differ fundamentally from the experimental value, this within an accuracy of about one percent. Consequently, omission of the magnetic islands yields an incorrect value $q^* \approx 1.55$, and an additional change to half of the correct Land factor results in $q^* \approx 1.77$. That the correct forms of the magnetic flux and the magnetic moment become connected with a correct value of the deduced elementary charge, can therefore be taken as a strong support of the present theory. Moreover, with wrong values of the magnetic flux and Land factors, also the values of magnetic moment M_0 and mass m_0 would disagree with experiments.

The Lorentz invariance of the electron radius can be formally satisfied, in the case where this radius is allowed to shrink to that of a point charge. The obtained results can on the other hand also apply to the physically relevant situation of a small but nonzero radius of a configuration having an internal structure.

The configuration of the electron model can be prevented from “exploding” under the influence of its eigencharge and the electrostatic volume force $\bar{\rho}\mathbf{E}$. This is due to the presence of the magnetically confining volume force $\bar{\rho}\mathbf{C} \times \mathbf{B}$ [18].

6.2 A Photon Model

Cylindrical waves appear to be a convenient starting point for a photon model, due to the aims of a conserved shape in a defined direction of propagation and of limited spatial extensions in the transverse directions. In a cylindrical frame (r, φ, z) the velocity vector is here given by the form

$$\mathbf{C} = c(0, \cos \alpha, \sin \alpha) \quad (30)$$

where $\sin \alpha$ will be associated with the propagation and $\cos \alpha$ with the spin. In the case of axisymmetric waves, equation (22) yields

$$\omega = kv, \quad v = c(\sin \alpha) \quad (31)$$

for normal modes which vary as $f(r) \exp[i(-\omega t + kz)]$. The angle α should be constant since astronomical observations indicate that light from distant objects has no dispersion. The basic equations result in general solutions for the components of \mathbf{E} and \mathbf{B} , in terms of a generating function

$$F(r, z, t) = E_z + (\cot \alpha) E_\varphi = G_0 G, \quad (32)$$

$$G = R(\rho) \exp[i(-\omega t + kz)]$$

and its derivatives. The dispersion relation (31) shows that the phase and group velocities along the z direction of propagation are smaller than c . Not to get in conflict with the experiments by Michelson and Moreley, we then have to restrict ourselves to a condition on the spin parameter $\cos \alpha$, in the form

$$0 < \cos \alpha \ll 1 \quad v/c \approx 1 - \frac{1}{2}(\cos \alpha)^2. \quad (33)$$

From the normal mode solutions, wave-packets of narrow line width can be deduced, providing expressions for the corresponding spectrally integrated field strengths $\bar{\mathbf{E}}$ and $\bar{\mathbf{B}}$. The latter are further used in spatial integrations which lead to a net electric charge $q = 0$ and net magnetic moment $M = 0$, as expected, and into a nonzero total mass $m \neq 0$ due to the mass-energy relation by Einstein, as well as to a nonzero spin $s \neq 0$ obtained from the Poynting vector and equation (8). There is also an associated very small photon rest mass $m_0 = m(\cos \alpha)$. Thus a nonzero spin and a nonzero photon rest mass become two sides of the same intrinsic property

which vanishes with the parameter $\cos \alpha$, i.e. with $\text{div} \mathbf{E}$. Due to the requirement of Lorentz invariance, a nonzero $\cos \alpha$ thus implies that a nonzero spin arises at the expense of a slightly reduced momentum and velocity in the direction of propagation. This is a consequence of the generalized Lorentz invariance in Section 4.

In this connection it has to be added that the alternative concept of a momentum operator $\mathbf{p} = -i\hbar\nabla$ has been applied to a massive particle in the Schrödinger equation [2]. As compared to the momentum density \mathbf{g} of equation (7), however, the operator \mathbf{p} leads to physically unrealistic transverse components for a cylindrically symmetric and spatially limited wave-packet model of the photon.

With a radial part of the generating function (32) being of the form

$$R(\rho) = \rho^\gamma e^{-\rho} \quad (34)$$

there are two options, namely the convergent case of $\gamma > 0$ and the divergent one of $\gamma < 0$. In the convergent case combination of the wave-packet solutions for a main wavelength λ_0 with the quantum conditions

$$m = h/c\lambda_0 \quad s = h/2\pi \quad (35)$$

results in an effective transverse photon radius

$$\hat{r} = \frac{\lambda_0}{2\pi(\cos \alpha)} \quad \gamma > 0. \quad (36)$$

In the divergent case a corresponding procedure has to be applied, but with inclusion of a revised renormalization being analogous to that applied to the electron. With the corresponding smallness parameter ϵ the effective photon radius then becomes

$$\hat{r} = \frac{\epsilon\lambda_0}{2\pi(\cos \alpha)} \quad \gamma < 0. \quad (37)$$

The results (36) and (37) can be considered to represent two modes. The first has relatively large radial extensions as compared to atomic dimensions, and for $\epsilon/(\cos \alpha) \ll 1$ the second mode leads to very small such extensions, in the form of “needle radiation”. Such radiation provides explanations of the photoelectric effect, and of the occurrence of the dot-shaped marks on a screen in double-slit experiments [12]. The two modes (36) and (37) are based on the broken symmetry and have no counterpart in conventional theory. They can also contribute to an understanding of the two-slit experiments, somewhat in the sense of the Copenhagen school of Bohr and where an individual photon makes a transition between the present modes, in a form of “photon oscillations” including both a particle behavior and that of wave interference, as stated by the author [19]. Such oscillations would become analogous to those of neutrinos which have nonzero rest masses.

The nonzero electric field divergence further leads to intrinsic electric charges of alternating polarity within the body of an individual photon wave packet. This contributes to the understanding of electron-positron pair formation through the impact of an external electric field from an atomic nucleus or from an electron, as proposed by the author [20].

There is experimental evidence for the angular momentum of a light beam of spatially limited cross-section, as mentioned by Ditchburn [21]. This can be explained by contributions from its boundary layers, in terms of the present approach.

The wave equations of this theory can also be applied to cork-screw-shaped light beams in which the field quantities vary as $f(r) \exp[i(-\omega t + \bar{m}\varphi + kz)]$ and where the parameter \bar{m} is a positive or negative integer. The dispersion relation then becomes

$$\omega/k = c(\sin \alpha) + (\bar{m}/kr)c(\cos \alpha). \quad (38)$$

The normal modes and their spectrally integrated screw-shaped configurations then result in a radially hollow beam geometry, as observed in experiments described by Battersby [22] among others.

For the W^+ , W^- and Z^0 bosons, a Proca-type equation being analogous to that of the present theory can possibly be applied in the weak-field case. This would then provide the bosons with a nonzero rest mass, as an alternative to the Higgs concept.

With the present theory of the vacuum state as a background, fermions like the electron and neutrino, and bosons like the photon, could be taken as concepts with the following characteristics. The fermions can be made to originate from the steady-state field equations, represent “bound” states, and have an explicit rest mass being associated with their spin. This does not exclude that moving fermions also can have wave properties. The bosons originate on the other hand from the dynamic wavelike field equations, represent “free” states, and have an implicit rest mass associated with their spin. They occur as quantized waves of the field which describe the interaction between the particles of matter.

7 New consequences of present theory

Among the fundamental new consequences which only come out of the present theory and also strongly support its relevance, the following should be emphasized:

- Steady electromagnetic states lead to rest masses of leptons.
- A nonzero electronic charge is by necessity connected with a point-charge-like geometry.
- A deduced electronic charge agreeing with the experimental value results from correct forms of the magnetic moment and magnetic flux, but not from other forms.
- A confining magnetic force prevents the electron from “exploding” under the influence of its eigencharge.

- Electromagnetic waves and their photon models possess spin.
 - There are needle-like wave solutions contributing to the understanding of the photoelectric effect and of two-slit experiments.
 - The angular momentum of a light beam can be explained.
20. Lehnert B. Wave-particle properties and pair formation of the photon. In *Frontiers of Modern Plasma Physics*, Edited by P. K. Shukla, B. Eliasson and L. Stenflo, American Institute of Physics, Melville, NY, USA, 2008, 282–291.
 21. Ditchburn R. W. *Light*. Academic Press, London, New York, San Francisco, 1976, Third edition, Sec. 17. 24.
 22. Battersby S. Twisting the light away. *New Scientist*, 12 June 2004, 37–40.

Submitted on February 7, 2012 / Accepted on February 17, 2012

References

1. Feynmann R. P. *Lectures on Physics: Mainly Electromagnetism and Matter*. Addison-Wesley, Reading, MA, 1964, 28.
2. Schiff L. I. *Quantum Mechanics*. McGraw-Hill Book Comp., Inc., New York-Toronto-London, 1949, Ch. XIV; Ch. II, Sec. 6.
3. Heitler W. *The Quantum Theory of Radiation*. Third edition, Oxford, Clarendon Press, 1954, Appendix, 409; 31.
4. Quigg C. The coming revolution in particle physics. *Scientific American*, February 2008, 38–45.
5. Morse P. M. and Feshbach H. *Methods of Theoretical Physics*. McGraw-Hill Book Comp., Inc., New York-Toronto-London, 1953, Part I, 260–261.
6. Higgs P. W. Spontaneous symmetry breakdown without massless bosons. *Physical Review*, 1966, v. 145, 1156–1163.
7. Ryder L. H. *Quantum Field Theory*. Second edition, Cambridge University Press, 1996, 397; Ch.9.
8. Jackson J. D. *Classical Electrodynamics*. John Wiley & Sons, Inc., New York, London, Sydney, 1962, Sec. 17.4.
9. Stratton J. A. *Electromagnetic Theory*. First edition, McGraw-Hill Book Comp., Inc., New York-Toronto-London 1941, Ch. I, Sec. 11. 1; Sec. 6. 7.
10. Halln E. *Electromagnetic Theory*. Chapman and Hall, London, 1962, Sec. 34.
11. Lehnert B. The failure of Maxwell's equations as a basis for a photon model in the vacuum state. *International Review of Physics*, 2008, v. 2, no. 6, 337–340.
12. Tsuchiya Y., Inuzuka E., Kurono T., and Hosoda M. Photo-counting imaging and its application. *Advances in Electronics and Electron Physics*, 1985, v. 64A, 21–31.
13. Lehnert B. *A Revised Electromagnetic Theory with Fundamental Applications*. Edited by Z. I. Vakhnenko and A. Z. Zagorodny, Bogolyubov Institute for Theoretical Physics, Kiev 2008; Edited by D. Rabounski, Swedish Physics Archive, The National Library of Sweden, Stockholm 2008; *Revised Quantum Electrodynamics*. In the series "Contemporary Fundamental Physics" edited by V. V. Dvoeglazov, Nova Science Publishers, Inc., Hauppauge 2012, New York, USA.
14. Lehnert B. *Revised Quantum Electrodynamics with Fundamental Applications*. In *New Aspects of Plasma Physics*, Edited by P. K. Shukla, L. Stenflo and B. Eliasson, World Scientific Publishing Co. Pte. Ltd., Singapore 2008, 52–36.
15. Lehnert B. Deduced fundamental properties of the electron. *International Review of Physics*, 2010, v. 4, no. 1, 1–6.
16. Feynman R. *QED: The Strange Theory of Light and Matter*. Penguin, London, 1990.
17. Lehnert B. and Scheffel J. On the minimum elementary charge of an extended electromagnetic theory. *Physica Scripta*, 2002, v. 65, 200–207.
18. Lehnert B. and Hk L. J. An electron model with elementary charge. *Journal of Plasma Physics*, 2010, v. 76, 419–428.
19. Lehnert B. The individual photon in two-slit experiments. *International Review of Physics*, 2011, v. 5, no. 1, 15–18.

Parameterized Special Theory of Relativity (PSTR)

Florentin Smarandache
 University of New Mexico, Gallup, NM 87301, USA
 E-mail: smarand@unm.edu

We have parameterized Einstein’s thought experiment with atomic clocks, supposing that we knew neither if the space and time are relative or absolute, nor if the speed of light was ultimate speed or not. We have obtained a Parameterized Special Theory of Relativity (PSTR), first introduced in 1982. Our PSTR generalized not only Einstein’s Special Theory of Relativity, but also our Absolute Theory of Relativity, and introduced three more possible Relativities to be studied in the future. After the 2011 CERN’s superluminal neutrino experiments, we recall our ideas and invite researchers to deepen the study of PSTR, ATR, and check the three new mathematically emerged Relativities 4.3, 4.4, and 4.5.

1 Einstein’s thought experiment with the light clocks

There are two identical clocks, one is placed aboard of a rocket, which travels at a constant speed v with respect to the Earth, and the second one is on the Earth. In the rocket, a light pulse is emitted by a source from A to a mirror B that reflects it back to A where it is detected. The rocket’s movement and the light pulse’s movement are orthogonal. There is an observer in the rocket (the astronaut) and an observer on the Earth. The trajectory of light pulse (and implicitly the distance traveled by the light pulse), the elapsed time it needs to travel this distance, and the speed of the light pulse at which is travels are perceived differently by the two observers (depending on the theories used — see below in this paper).

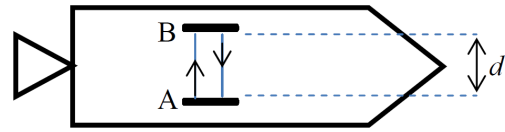

Figure 1

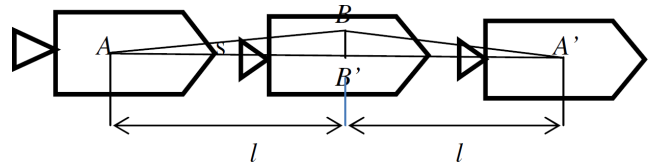

Figure 2

According to the astronaut (see Fig. 1):

$$\Delta t' = \frac{2d}{c}, \tag{1}$$

where $\Delta t'$ time interval, as measured by the astronaut, for the light to follow the path of double distance $2d$, while c is the speed of light.

According to the observer on the Earth (see Fig. 2):

$$\left. \begin{aligned} 2l &= v \Delta t, \quad s = |AB| = |BA'| \\ d &= |BB'|, \quad l = |AB'| = |b'A'| \end{aligned} \right\}, \tag{2}$$

where Δt is the time interval as measured by the observer on the Earth. And using the Pythagoras’ Theorem in the right triangle $\Delta ABB'$, one has

$$2s = 2 \sqrt{d^2 + l^2} = 2 \sqrt{d^2 + \left(\frac{v \Delta t}{2}\right)^2}, \tag{3}$$

but $2s = c \Delta t$, whence

$$c \Delta t = 2 \sqrt{d^2 + \left(\frac{v \Delta t}{2}\right)^2}. \tag{4}$$

Squaring and computing for Δt one gets:

$$\Delta t = \frac{2d}{c} \frac{1}{\sqrt{1 - \frac{v^2}{c^2}}}. \tag{5} \text{ or}$$

Whence Einstein gets the following time dilation:

$$\Delta t = \frac{\Delta t'}{\sqrt{1 - \frac{v^2}{c^2}}}. \tag{6}$$

where $\Delta t > \Delta t'$

2 Parameterized Special Theory of Relativity (PSTR)

In a more general case when we don’t know the speed x of the light as seen by the observer on Earth, nor the relationship between $\Delta t'$ and Δt , we get:

$$x \Delta t = 2 \sqrt{d^2 + \left(\frac{v \Delta t}{2}\right)^2}. \tag{7}$$

But $d = \frac{c \Delta t'}{2}$, therefore:

$$x \Delta t = 2 \sqrt{\left(\frac{c \Delta t'}{2}\right)^2 + \left(\frac{v \Delta t}{2}\right)^2}, \tag{8}$$

$$x \Delta t = \sqrt{c^2(\Delta t')^2 + v^2(\Delta t)^2}. \tag{9}$$

Dividing the whole equality by Δt we obtain:

$$x = \sqrt{v^2 + c^2 \left(\frac{\Delta t'}{\Delta t} \right)^2}. \quad (10)$$

which is the *PSTR Equation*.

3 PSTR elapsed time ratio τ (parameter)

We now substitute in a general case

$$\frac{\Delta t'}{\Delta t} = \tau \in (0, +\infty), \quad (11)$$

where τ is the PSTR elapsed time ratio. Therefore we split the Special Theory of Relativity (STR) in the below ways.

4 PSTR extends STR, ATR, and introduces three more Relativities

4.1 If $\tau = \sqrt{1 - \frac{v^2}{c^2}}$ we get the STR (see [1]), since replacing x by c , one has

$$c^2 = v^2 + c^2 \left(\frac{\Delta t'}{\Delta t} \right)^2, \quad (12)$$

$$\frac{c^2}{c^2} - \frac{v^2}{c^2} = \left(\frac{\Delta t'}{\Delta t} \right)^2, \quad (13)$$

or $\frac{\Delta t'}{\Delta t} = \sqrt{1 - \frac{v^2}{c^2}} \in [0, 1]$ as in the STR.

4.2 If $\tau = 1$, we get our *Absolute Theory of Relativity* (see [2]) in the particular case when the two trajectory vectors are perpendicular, i.e.

$$X = \sqrt{v^2 + c^2} = |\vec{v} + \vec{c}|. \quad (14)$$

4.3 If $0 < \tau < \sqrt{1 - \frac{v^2}{c^2}}$, the time dilation is increased with respect to that of the STR, therefore the speed x as seen by the observer on the Earth is decreased (becomes subluminal) while in STR it is c .

4.4 If $\sqrt{1 - \frac{v^2}{c^2}} < \tau < 0$, there is still time dilation, but less than STR's time dilation, yet the speed x as seen by the observer on the Earth becomes superluminal (yet less than in our Absolute Theory of Relativity). About superluminal velocities see [3] and [4].

4.5 If $\tau > 1$, we get an *opposite time dilation* (i.e. $\Delta t' > \Delta t$) with respect to the STR (instead of $\Delta t' < \Delta t$), and the speed x as seen by the observer on earth increases even more than in our ATR.

5 Further research

The reader might be interested in studying these new Relativities mathematically resulted from the above 4.3, 4.4, and 4.5 cases.

Submitted on February 6, 2012 / Accepted on February 12, 2012

References

1. Einstein A. Zur Elektrodynamik bewegter Körper. *Annalen der Physik*, 1905, v. 17, 891–921.
2. Smarandache F. *Absolute Theory of Relativity and Parameterized Special Theory of Relativity and Noninertial Multirelativity*. Somipress, 1982, 92 p.
3. Smarandache F. There is No Speed Barrier in the Universe. Liceul Pedagogic Rm. Vâlcea, Physics Prof. Elena Albu, 1972.
4. Rabounski D. A blind pilot: who is a super-luminal observer? *Progress in Physics*, 2008, v. 2, 171.

The Surjective Monad Theory of Reality: A Qualified Generalization of Reflexive Monism

Indranu Suhendro
www.zelmanov.org

What remains of presence and use in the universal dark (or perhaps, after all, in a too luminous, sight-blinding place), when mirrors are traceless as if without glass, when eyes are both mindfully and senselessly strained: wakeful but not ultimately cognizant enough — being a splendid spark at best, but incapable of self-illumination and shedding light on existents as if (situated) in themselves —, when no reflection remains within and without? Indeed, only that exceedingly singular, somewhat pre-existent (i.e., pre-reflexive) Motion and Moment without reflection inheres, which is our characteristic redefinition of Noesis or Surjectivity. This, since Reality can in no way be reduced to Unreality, even in such noumenal darkness where existence and non-existence are both flimsy, for otherwise at once — at one universal Now and Here — all would cease to exist, “before before” and “after after”; and yet all that, nay Being itself, already exists with or without (the multiplicity of) reflective attributes, i.e., without the slightest chance to mingle, by both necessity and chance, with Non-Being and hence with multiplicity! That is simply how chanceless Reality is in itself, suddenly beyond both the possible and the impossible, such that even Unreality (as it is, without history), which is a lingering “backwater part” of the Universe after all, can only be (i.e., be “there”, even if that simply means “nothing”, “nowhere”) if and only if Reality *IS*, i.e., if Reality is One even without operational-situational sign or space in the first place, and not the other way around. Such, then, is what chance, i.e., the chance of reflection, may mean in the Universe — and not elsewhere: Reality is such that if it weren’t Such, both Reality and Unreality would be Not, ever. He who fails to see this at once — as One — will not be able to understand the rest of the tale, Here and Now (or, as some say, “Now-Here”, “Nowhere”, or as Wittgenstein would have put it, “senselessly”), with or without the Universe as we commonly know it. — A first self-query in epistemic solitude.

1 Introduction: silently in the loud background of things

“Come, like a gush of early bewilderment abruptly arriving at the edge of time. Let us sort ourselves out from the loudness of things here.”

The present elucidation is not a “consciousness study”. It is a conscious expression of Reality. It is a symptom of consciousness, a deliberation of knowing. Or, as some would say, “it’s a proof, like music, rain, or a tempest”. It is a self-orchestrated pulsation and presencing without truncation even by silent objectivity, just as one may paint certain scenes of Sun-brushed magnolia eyes and long coral noons, or perhaps the deep winter rain and the seamless Moon-lit snow — simply like a mindful artist reminded of nudity during certain cavernous moments, nearly without a mirror capturing his inward constellation of motions. And so he moves, as it is, simultaneously before and after reflection, as if moving away from time itself. And so it moves, the entire reflection included.

Despite the possibly glacial theoretical sounding of the title and the way the text shall proceed from here (perhaps inconsistently), it is essentially not another viscid gathering of scholastic words on monism, let alone an ecstatic, bemused

first-time attempt at modeling Reality. It is not a theory in the sense of mental speculation and inspirational belief: it is Presence and Idea before and after philosophy, and a direct presentation and “surdetermination” during philosophy. Thus, it is not a mere representation, for it does not even begin with reflection. Rather, the entirety of reflection is but momentous and strengthened only by what truly precedes and surpasses it. It is not a psychological documentary multi-linearly tinged with philosophical armor and scientific draping. It is not a predictable philosophy in the rear. It is not a lucrative science as the world knows it. It is a mirror for worlds, anti-worlds, and all the non-worlds. And sometimes this very mirror does vanish, for absolute certainty’s sake.

This is an exposition to be enjoyed the most by self-similar “stray falcons”, who can’t help with their epistemic-intellectual speed and Genius, whose taste — upon the wind and beyond distant hills — is beyond that of the herd and the faltering, image-dependent, super-tautological world as a whole. It is not intended to be a secure throne in the sky nor a comfy haven on the Earth. Also, it is definitely not for the hideous, vainly copious one-dimensional intellect devoid of the valley’s affection and the seasons’ intimation. It is a silence-breaking tempest and a self-sustaining root in the most evident evening, entirely independent of the small

sparks of the present age of thought. It calls upon witnessing the Witness (and the Witnessed) in infinite exhaustiveness, intimidation, and silence.

It is incumbent upon the reader to acknowledge that the present exposition's veracity is to be grasped not by merely studying it, but by "studying it, not studying it, not-not studying it, and by none of these" (as to why, it shall be clear later). While Reality is not situational (as we shall see), the surreptitious meta-situation here is that, while there is an entire history of human ideas in the background of the world at any instant, its content moves not on any regularly known ground of being, so basically even the intrepid reader cannot compete with its velocity and vortex, for it is ahead of his reading, behind it, within it, and without it. And it is none of these.

Still, let the burning lines of the night and the time-span of the intellect's long orbit be epistemologically intimidated. For even if there is nothing to be seen and understood by the reader here, that one shall still see "seeing" itself, beyond mere "spiritism", however indifferent.

And so here falls headlong the platitudinous introductory tone first. Granted, it shall evaporate away soon enough, once the most unlikely epistemic sensitivity happens to the reader.

At the forefront of humanity — which is definitely a conscious, self-reflective episode in the evolution of the cosmos, according to the famous Anthropic Principle of cosmology and cosmogony — there is no need to explain why one needs to fully explore the nature of consciousness philosophically and scientifically, i.e., unless one is a dead-end dogmatist who, however taut, probably dares not "swear upon his own life, as to whether or not his beliefs are universally true after all".

The present semantic-ontological exposition centers around a further (or furthest possible) development of the theory of consciousness called "Reflexive Monism" (*RM*) — hereby referred to as the "Surjective Monad Theory of Reality" (*S MTR*).

By contrast, the version of realism called "Biological Naturalism" (*BN*) posits that consciousness is merely an emergent property of inanimate matter: everything that exists is necessarily inside the material brain, possibly as a quantum state. Thus, there is "no world inside the mind" — and so there is no "mind" (only a material brain) — and consciousness is but a field (electromagnetic, perhaps) activity involving the neuronal circuitry. Connected to this (and the theory of "Artificial Intelligence", *AI*), is the theory of Multiple Intelligences (*MI*), which advocates "consciousness" as a collective state of material brains via a global circuit mechanism, necessitating the existence of multiple participants — ultimately leaving no room for an individual brain, let alone an individual mind in the Universe (and hence, one could say, no room for a real solitary Genius at all, since *MI*-consciousness is always a collective pseudo-democratic state, no matter how transparent), for phenomenal multiplicity (rather than the self-cognizant, inhering presence of a single universal intel-

ligence) is at the very core of this form of materialism. Yet, consider this now-generic example as, e.g., conveyed by Velmans [1]. Suppose, convinced like many merely collectivistic scientists today, one accepts *BN*, then by definition one also accepts the whole world (nay, the Universe) as contained in the material brain. But most of every-day objects, including the skies and the horizons, seem to be located "out there" — that is, outside the brain. Thus, in order to encapsulate all that in a single material brain, one must accept that there is a "real skull" (whether or not certain "noumena" are known to one here) whose size is beyond that of the skies and the horizons, since physically the brain is contained in a skull. The "real skull" would then be related to individual skulls through some kind of "statistical-holographic averaging". The difference between "is" and "seems" becomes so arbitrary here, as we can easily see.

On the other hand, the history of human thought presents us with "Pure Idealism" (*PI*) — such as that advocated by Berkeley in one of its versions — where the world is but a mental entity, purely located inside the mind. By "world", we mean all that can exist as a single situational adage and corollary of reflective facts, including qualia (the trans-optical reality of color) and psychosomatic sensations. According to *PI*, there is "no world out there". In this approach, the mind is distinguished from the material brain, with the brain being a material self-representation of the mind, and everything is necessarily contained in the mind — yet with serious troubles for, like *BN*, it is without clear epistemic qualifications regarding the notion of individual and multiple entities: according to this theory, one might be tempted to see whether or not the Universe too ceases to exist, when an arbitrary mind (anyone's mind) dies out. Non-epistemologically positing essentially "eternal souls" does not really help either. (As regards qualia, we shall readily generalize this notion to include not just color, but also subsume it in the category spanned by the pre-reflexive "Surject", i.e., "Qualon" — precisely so as not to take the abstract phenomenological entity for granted.)

Such radical, self-limited approaches leave room for both "dogmatism" and "relativism", and consequently have their own drawbacks as shown, e.g., in Velmans' studies. Indeed in the face of Reality, one cannot help but be radical and isolated, whether shivering or rasping, but true epistemological qualification (herein to be referred to as "eidetic qualification") is quite profoundly something else. Velmans himself — formerly a proponent of *BN* — is a cogent philosophical proponent of *RM* and has indeed very extensively explored this reality theory, especially its aspects pertaining to cognitive psychology. Yet, we shall naturally go even beyond him in "imbibing Reality", hence the present theory as our basic ontological paradigm.

As is evident, *RM* is a version of realism adopted by thinkers such as Spinoza, Einstein (but not specifically its associated pantheism), and Velmans — which goes beyond *BN* and *PI*. Reality is said to isomorphically partake of events

(mental and material instances) both inside and outside the brain — and the mind.

Let us attempt to paraphrase *RM* as follows: the most fundamental “stuff” of the Universe is a self-intelligent, self-reflexive (“autocameral”) substance beyond both (the commonly known) mind and matter, possibly without an “outside” and an “inside” in the absolute sense (think of a Möbius strip or a Klein bottle, for instance). And yet, locally and “conspansively” (for the original use of this term, see also [2]: here “conspansion” is to be understood as self-expression and self-expansion within the semantics and syntax of universal logic), it produces intrinsic mind and extrinsic matter — as we know them.

In our present theory, this underlying substance is further identified as a non-composite self-intelligent Monad (“*Nous*”), without any known attribute whatsoever other than “surjective, conscious Being-in-itself”: we can make no mention of extensivity, multiplicity, and the entire notion of knowledge set at this “level” of Reality, whether subjectively or objectively, or both simultaneously. Otherwise, inconsistent inner multiplicity associated with reflection would somehow always have to qualify (i.e., ontologically precede) Being not only as being self-situational or self-representational, but also as being “accidentally none of these”. Such is absurd, for then it must also hold in the sheer case of Non-Being, i.e., without both existence and such multiplicity-in-itself and -for-itself. Being pre-reflexive, and hence pre-holographic and pre-homotopic, the true meaning of this point shall be effortlessly self-evident as we proceed from here. This is the reason why our *Nous* has no superficial resemblance with arbitrary phenomenal intelligence, let alone substance.

And yet the very same Monad sets out the emergent properties of reflexivity, holography, and homotopy with respect to the Universe it emergently, consciously sees (or “observes”, as per the essential element of quantum mechanics: the observer and elementary particles are both fundamental to the theory). It is necessarily, inevitably “intelligent” since it positively spans (knows) the difference between existence and non-existence and thereby fully augments this distinction in that which we refer to as the Universe or Reality’s Trace, which individual intelligences may reflect in various degrees of “motion” and “observation”. Otherwise, no one in extension would ever know (or have the slightest conscious power to know) the distinction between existence and non-existence; between the conscious and the unconscious — and further between absolute singular existence and various epistemological categories of multiplicity. Verily, this forms the basis of our paradigm for a fully intelligent cosmos — and further qualified versions of the Anthropic Principle.

Furthermore, our framework manifests a theory of Reality via four-fold universal (trans-Heraclitean) logic, which is beyond both conventional (binary) and fuzzy logics — as well as beyond Kantian categorical analysis. Given a super-set ($\{A, B\}$), where $\{A\}$ is a collection of abstract principles,

$\{B\}$ is a collection of emergent realities isomorphic to the entirety of $\{A\}$, and the super-set $()$ is “eidetically symmetric” (the meaning of which shall become clear later) with respect to its elements, it contains the full logical span of “*A*”, “non-*A*”, “non-non-*A*”, and that which is “none of these” (how it differs from traditional Buddhist logic will become clear later as well). As such, one may inclusively mention a maximum span of truly qualified universals, including ontological neutralities. This gives us a “surjective determination of Reality”, whose fundamental objects are related to it via infinite self-differentiation, as distinguished from Unreality.

While so far the reader is rigged with limited equipment — for, at this point, we have not introduced the essence and logical tools of the present theory to the reader — we can nevertheless roughly depict Reality accordingly, i.e., we shall start with “thinking of thinking itself” and “imagining the dark”. For this we will need one to imagine an eye, a mirror, a pitch-dark room (or infinite dark space), and circumferential light. Then, the following self-conclusive propositions follow:

P₁. In the pitch-dark room (“Unreality”), there exists an Ultimate Observer (“Eye”) that sees the pure, luminous mirror. The mirror is the Universe — henceforth called the “Mirror-Universe” — which is a “bare singularity” with respect to itself, but which is otherwise multi-dimensional (for instance, *n*-fold with respect to the four categorical dimensions of space-time, matter, energy, and consciousness, let alone the Universe itself).

P₂. The circumferential light augments both the mirror and the sense of staring at it, resulting in the image of an “eye” (or “eyes”, due to the multiple dimensions of the Mirror-Universe) and a whole range of “eye-varied fantasies” — which is the individual mind and a variational synthesis of that very image with the dark background — where that which is anyhow materialized readily borders with Unreality.

P₃. The circumferential light is, by way of infinite self-differentiation (and transfinite, self-dual consciousness), none other than (universal) consciousness.

P₄. Reality is the Eye, the Consciousness, the Mirror, the Image, and the “Eye-without-Eye”. This can only be understood later by our four-fold universal logic encompassing the so-called “Surjectivity” (*Noesis*) — with the introduction of “Surject” at first overwhelming both “Subject” and “Object” (in addition to “Dimension”) in this framework, but as we shall see, only this very “Surject” ultimately defines “Moment” (and not just a universal continuum of three-dimensional space and sequential time) and “Uniqueness” (and not just the “totality of consistent and inconsistent facts”) four-fold: “within”, “without”, “within-the-within”, and “without-the-without”, ultimately corresponding to the paramount qualification of Reality for itself and, subsequently, its associated “class of Surjects” in the noumenal and phenomenal world-realms.

Before we proceed further by the utilization of the above

similes, we note in passing that the underlying monad of any reflexive model of the Universe is none other than mind and matter at once, when seen from its phenomenal-organizational-relational aspect, a property which constitutes — or so it seems — both the semantics and syntax of the Universe, especially when involving conscious observers such as human beings. That is, noumenally (in-itself, for instance in the Kantian sense), the Universe is consciousness-in-itself, and phenomenally (in relation to the way its intelligibility inheres by means of extensive objects), it is a self-dual reality with a multiverse of material and mental modes of existence. But, as we shall see, there is a lot more to our adventure than just this: hence our generalization.

So much for a rather self-effacing introduction, in anticipation of the irregular dawning of things on the reader's mental window. Before we proceed further, let us remark on the rather speculative nature of "excess things" regarding the subject of *RM* in general: while, in general, mind cannot be reduced (transformed) into matter and vice versa, there exists subtle interactive links between them that should be crucially discerned by pensive research activities so as to maximally relate the philosophical dialectics of consciousness and technological endeavors, i.e., without causing philosophy, yet again, to get the "last mention". For, to partake of Reality as much as possible, humans must simply be as conscious as possible.

2 The gist of the present epistemology: the surjective qualon

"Mere erudite logic often turns — as has been generically said — philosophy into folly, science into superstition, and art into pedantry. How far away from creation and solitude, from play and imagination, from day and night, from noon and silhouette it is! How Genius is precisely everything other than being merely situational, alone as the Universe."

Herein we present a four-fold asymmetric theory of Reality whose essence — especially when properly, spontaneously understood — goes beyond the internal constitutions and extensive limitations of continental and analytic philosophies, including classical philosophy in its entirety (most notably: Platonism, neo-Platonism, atomism, dualism, and peripatetic traditions), monism (Spinoza-like and others), sophistic relativism and solipsism (which, as we know, has nothing to do with the actuality of the Einsteinian physical theory of relativity), dogmatic empiricism and materialism, Kantianism and neo-Kantianism, Hegelianism and non-Hegelian dialectics (existentialism), Gestalt psychology, symbolic logic, hermeneutics, and all phenomenology. This, while leaving the rather arbitrary self-triviality of major super-tautological (collectivistic, ulterior, inter-subjective) and post-modern, post-structural strands of thought in deliberate non-residual negligence — for, abruptly starting at the level of axiology and being generically "not even wrong" in short or at length,

these are devoid of real ontological-epistemological weight in our view.

The new ontological constitution under consideration is four-fold and asymmetric in the sense that there exist four levels necessitating both the Universe and Unreality, i.e., Reality, the Reflexive Mirror-Universe, the Projective World-Multiplicity, and Unreality, whose *eidetic connective distances* (i.e., "foliages" or "reality strengths") are *telically* (i.e., multi-teleologically) direction-dependent and not arbitrarily symmetric among themselves unless by means of *Noesis*, by which the very theory is said to be *eidetically qualified* (i.e., qualified by *Eidos*, or Suchness — be it Alone without even specific reference to the Universe at all, or when noumenally and associatively designated as All or All-in-All) — and hence self-unified and self-unifying with respect to an entirely vast range of phenomenological considerations.

It is to be noted that Surjectivity, as implied by the very term *Noesis*, in our own specific terminology is associated with *Nous*, or the Universal Monad, which is none other than the *First Self-Evident Essence* through whose first qualitative "Being-There" (*Ontos qua Qualon*) the ontological level, and not just the spatio-temporal level, is possible at all, especially as a definite, non-falsifiable concentration of knowledge.

Thus, in particular, the classical Socratic-Hegelian dialectics of thesis, anti-thesis, and synthesis is herein generalized to include also *Noesis*, but rather in the following *asymmetric, anholonomic* order: *Noesis* (via the Ontological Surjective "Surject", i.e., "Qualon"), *Synthesis* (via the Epistemological Reflexive "Dimension", i.e., "Prefect"), Thesis (via the Reflective Dimensional "Object-Subject", i.e., "Affect"), *Anti-Thesis* (via the Projective Dimensional "Subject-Object", i.e., "Defect"). This corresponds to the full creation of a new philosophical concept, let alone the Logos, by the presence of self-singular points and infinitely expansive perimeters.

The ontic (i.e., single monad) origin of the noumenal Universe is Reality itself, i.e., Reality-in-itself (Being-qua-Being) without any normatively conceivable notion of an internally extensive (self-reflexive) contingency (e.g., the usual context of cognition, information, syntax, simplex, and evolution) of inter-reflective, isomorphic, homotopic unity and multiplicity at all, let alone the immediate self-dual presence of subjects and objects (i.e., representational and observational categories, such as space-time and observers).

Thereafter, extensively, upon the emergence of the notion of a universe along with *universality*, i.e., *reflexivity* (encompassing, by noumenal and phenomenal extension, both *reflection* and *projection* — with the former being universal, ultimately akin to singularity and non-dual perception but still, in an austere sense, other than Reality itself, and with the latter being somewhat more inter-subjective and arbitrary, still bordering with the dark, shadowy vanity of Unreality), Reality is said to encompass primal, pre-geometric (i.e., "mirrorless", trans-imaginary, or *qualic*) singularities and transformational multiplicities (modalities) at successive levels capa-

ble of fully reflecting essence and existence in the four-fold Suchness of “within”, “without”, “within-the-within”, and “without-the-without”, where original noumena inhere only by means of *eidetic-noetic instance* (*Surjection*) without the necessity of phenomena whatsoever, but only the presence of the so-called “*Subject*” — that which is not known to regular epistemologies, for in a sense it is other than “subject”, “object”, and “dimension”. Only then do both noumena and phenomena appear *info-cognitively* by means of reflexive omnijectivity involving arbitrary subjects, objects, and epistemological dimensions (i.e., in fundamental semantic triplicity), which in turn is responsible for the reflective and projective self-dual modes of all abstract and concrete phenomenal existences — hence the emergence of the universal syntax, nearly as circular self-causality.

In elaborating upon the above allusions, we shall also introduce a post-Kantian four-fold universal logic (not to be confused with four-fold Buddhist logic or that which is associated with non-relativistic, semantics-based process philosophy) associated with an eidetically qualified kind of *non-composite consciousness*, which enables us to epistemologically generalize and elucidate the metaphysics (logical interior) of the so far sound-enough theory of Reflexive Monism (i.e., “sound-enough” at least at the “mesoscopic” stage of things, and in comparison with the majority of competing paradigms).

In connection with the elucidatory nature of this exposition, we shall adopt a style of narration as intuitive, lucid, and prosaic as possible — while being terse whenever necessary —, due to the otherwise simple ambiguity inherent in the association of Reality with a potentially inert scholastic theory (while there is subtle isomorphism between Reality and language at a descriptive stage, to the Wittgensteinian extent, as recorded in [5], that “that which can be spoken of, must be spoken of clearly, and that which cannot, must be withheld in utter silence”, how can Reality only be a “theory” or “philosophy” after all?): the profundity of the former is ultimately senseless and immediate, with or without deliberate systemization on our part, while the latter is but a singular, cognition-based contingency-in-itself (a logical enveloping singularity and yet always not devoid of the multiplicity of perceptual things, including those of plain syntactical undecidability).

3 Peculiar eidetic re-definitions: aprioristic terminology and essence

“May I suspect, friend, you know — arbitrarily — what appears. But, tell me, what IS?”

It is important to note that some of the eclectic terms employed throughout this exposition do not essentially depend on their scholastic historicity. It is immaterial whether or not they have come into existence through the collective jargon of the multifarious schools of all-time philosophers. (Needless to say, the same applies to scientific-sounding terms, without any attempt towards imparting to the reader’s mind a sense

of “pseudo-science” whenever touching upon aspects other than traditional science, for one must be most acutely aware of the profound tedium prevalent in much of the arbitrary literature of post-modernism and so-called “theosophy” in actual relation to pseudo-science, pseudo-spirituality, pseudo-philosophy, and pseudo-artistry.) Rather, whenever we use these terms, we would only like to further present them in the twice-innermost and twice-outermost sense: phenomenological instances have inner and outer meaning, and yet we wish to also encompass the “twice-inward” (twice-Unseen, twice-Real within-the-within) and “twice-outward” (twice-Manifest, twice-Real without-the-without) akin to Reality beyond simple constitutional duality and arbitrary individual fragments. This is simply a prelude to an amiable over-all description of the four-fold Suchness of Reality and its self-qualified primal noumena, which is not attributable to simple, eidetically unqualified “bi-dimensional” entities (whose common qualification is solely based on “this” and “other”, “yes” and “no”, or at most “yes and/or no”).

Now, in order to be trans-phenomenally readable, we may give the following list of five primary eidetic redefinitions (corollaries) essential to the outline of things here:

- Suchness (*S*) (*Eidos*): that which is manifestly There, as qualified by Being-in-itself, with or without existential reflexivity (the multiplicity of forms and mirrors);
- Monad (*N*) (*Nous*, *Monados*, *Ontos qua Qualon*): the first intelligible self-qualification (“*Qualion*”) of Reality and hence its first actual singularity, the noetic-presential “*U(N)*” of “Universum” (i.e., “*Qualon*”), with or without singular internal multiplicity of reflexive things (i.e., “*versum*”, or possible *extensa*) other than a “bare” eidetic (and hence noetic) being in and of Reality-in-itself (i.e., by its simply Being-There). Such is beyond both the traditional “*Atom*” and “*Platon*”, let alone the infinitesimals. It is simply the noumenal All and All-in-All, as well as the first eidetic-archetypal Singularity, with or without phenomenological “allness” (reflexive enclosure);
- Universe (*U*) (*Universum*, *Kosmos*): the noumenal-phenomenal four-fold Universe, i.e., the surjective, reflexive (multi-dimensionally reflective-transformational), projective, annihilatory universal foliation, ultimately without “inside” nor “outside”. The multi-space All by the Surjective Monad — simultaneously a multi-continuum and multi-fractality, being simultaneously Euclidean and non-Euclidean, geometric and pre-geometric, process and non-process (interestingly, see how all these seemingly paradoxical properties can exist in a single underlying multi-space geometry as described in [7] — see also a salient description of the essentially inhomogeneous physical cosmos in relation to random processes as presented in [12]). In other words, Reality’s singular Moment and infinite Reflex-

- ivity, with or without phenomenal space and time;
- Reality (M) (*Ontos qua Apeiron*): that which is the Real-by-itself. The self-subsistent Reality of Reality in-it-self (with or without *realities* — i.e., with or without internal self-multiplicity), the Surjective Monad, the Reflexive Universe, and Unreality. Here the austerity of the symbolic, presential letter “ M ” (for the essentially “Unlettered”) inheres absolutely without any vowel such that it is said that “nothing enters into it and nothing comes out of it”;
 - Surject (g) and/or Surjectivity (dg) (*Noesis, Epoche*): the first self-disclosing instance (“instanton”) of Reality, or such self-evident instances in existence. Reality is said not to act upon itself, for it is simply beyond categorical stillness and motion, and so it “acts” only upon the first reflexive mirror, the Universe, thereby capable of infusing new universally isomorphic *differentia* (“solitons”), i.e., new noumenal instances and new phenomenological events in the Universe (with respect to its trans-finite nature). In relation to it, the Universe is like a light-like (holographic, homotopic) mirror-canvas, a ground-base yet ever in motion, upon which the “Lone Artist” paints his “Surjects”. This is none other than the innermost nature of Genius (which differs, as we shall see here (i.e., by this more universal qualification) from mere superlative talent, just as eidetic surjectivity is beyond mere reflexivity).

As can be seen, each of the notions above is self-singular: these realities are self-similar among themselves, without categorical parallel apart from the ontological level. In other words, simply because Reality is One (Self-Singular), with or without reference to regular phenomenological (arithmetically countable) oneness, so are the Mirror, the Image, and the Shadow in essence.

As we shall witness in this exposition, all That (Reality, Monad, Universe, Unreality) can be given as follows:

$$M : N(U(g, dg)) \sim S,$$

where “:” denotes eidetic-noetic Presence (or Moment) and “ \sim ” represents transcendental equality as well as trans-individual self-similarity among the equation’s constituents. This, in a word, is more than sufficient to end our exposition at this early stage — for it is a self-contained proof of consciousness for itself —, as it is mainly intended for spontaneous cognizance, but we wish to speak more amiably of things along the epistemological perimeter of the intellect.

Non-composite Oneness belongs to Reality, so to speak, without having to be qualified or necessitated by that which is other than itself, simply because the self-necessary and the possible (existent), even the impossible (non-existent), can only be cognitively perceived “there” in and of the Real, not “elsewhere” by any other means, and not even by any presential concentration of singular multiplicity (i.e., ontologi-

cal and epistemological gatheredness). In other words, Reality is not diversifiable — and made plural — within and without, since it has no categorical “inside” nor “outside”, especially with respect to the discriminative entirety of cognition. Even absolute non-existence can only be conceived in, and necessitated by, Reality as a category — hence, in the absence of multiple intelligible things other than the supposedly primal “opposite” of pure existence, there is no actuality of absolute non-existence that can necessitate Reality as it is, nor is there anything phenomenal and noumenal that can cause it to mingle, in and across phenomenological time and space, with chance, causality, and mediation, let alone with singularly inconsistent multiplicity and Unreality. It is boundless not because it lies in infinite space, or because it is where infinite multiplicity inheres, or because it is a representation of eternity, or even because a finite entity is ultimately annihilated by “not knowing” and “non-existence” in the face of some infinite unknown, but because its ontological rank or weight (i.e., ontic-teleological reality) is without either immediate or extensive multiplicity in its own interiority or reflexive dimensionality, not even the entirety of “knowledge”. If this weren’t so, a single arbitrary reflective quantity could then also be shown to inhere intransitively (without existential predication), independently of Being, at any ontological level, *just as Being can always necessitate it predicatively*: for things to be situated in existence (extensivity), Being (Reality) must be there first absolutely without mingling with Non-Being (Unreality), *unlike the way things may phenomenologically mingle among themselves* (be it consistently or inconsistently). The metaphysical connection (the simplex of meta-logic) among ontological categories herein must then be, as will be shown shortly, asymmetric and anholonomic. Or else, there would be no discernment of the ontological weight of some absolute presence-essence (not in the way suggested by mere “essentialism”, where even in the case of arbitrary entification, essence must always precede existence), and there could be no logic whatsoever at subsequent levels of cognition, and isomorphism would be limited to the arbitrariness of inconsistent, self-flawed cognitive discrimination even on the phenomenological scale of things, which is not as trivial as the “arbitrariness of arbitrary things”.

This way, the Essence of Being is its own *Being-qua-Being*, which is identical, only in the “twice-qualified” sense, with the Being of Essence itself, i.e., “within-the-within” and “without-the-without”. Only in this ontological instance does eidetic asymmetry vanish.

It is not “logical”, and yet it is “not illogical” either — for the entirety of “logic”, “anti-logic”, and “non-logic” can only be traced (conceptualized) in its presence, with or without the necessity of accidental particularities. For instance, then, when we say “universe” without this qualification, we can still come up with the notion of “multiverse” while often still retaining space-time categories or attributes, or a plethora of schizophrenic universes “apart” from each other in one way

or another, and yet we cannot anyhow apply the same splitting and extensivity, or diffeomorphism, to Reality itself in order to make it appear as a co-dependent and co-differential among others outside its own necessity.

Reality, therefore, is not a set, not a category, not a functor (or functional), not of the likeness of both objective tangible matter (*materia*) and subjective abstract forms (*forma, qualia*). It is neither regular nor aberrant, as commonsense and traditional phenomenology would have “being” defined at best as “inconsistent multiplicity in and of itself”. It is not a representation of something that has to have a normative representation, be it abstract or concrete, conscious or unconscious. It simply *IS*, even when there is no language and count to express this, without the notion that consciousness is “always conscious of something” in association with the internal multiplicity of knowledge. However, the four-fold asymmetric universal logic to be sketched in the following section is Reality’s exception just as Reality is its exception: we can truly say a great deal of things by means of it, especially consciousness.

Know intuitively (at once, or never know at all) that if Reality weren’t Such, both Reality and Unreality would not only be unthinkable and imperceptible (however partial), they would not be, whether in existence or non-existence, in pre-eternity, at present, or in the here-after, in infinite contingency, finite extensivity, or universal emptiness, and there would be no universe whatsoever, finite or infinite, somewhere or nowhere, transcendent or immanent, — and none of these —, and no one would any likely embark upon writing this exposition at all!

Such is our blatant methodology by *Surjectivity* and eidetic redefinition, instead of both psychologism and the Husserlian phenomenological method of “bracketing”, which often amounts to either the “arbitrarily subjective over-determination” or the “arbitrarily objective suppression” of certain ontological constitutions already present among phenomenal categories.

4 Beyond Kant, phenomenology, and reflexivity: a four-fold, eidetically qualified universal logic with asymmetric, anholonomic categorical connection

“Now, I must tell you of something more tangible than all solid objects and more elusive than all traceless things in the heavens and on the Earth. Behold the highest branches of the tree of knowledge — untouched by reflection —, of which the night-in-itself is the garden.”

We are now in a position to outline the underlying features of our model of universal logic, which shall manifest the analytic epistemological sector of our present theory. In doing so, we will also make an immediate amiable comparison with the crux of Kantian epistemology, for the present case can be seen as a somewhat more universally deterministic generalization thereof.

As we have previously implied, it is important to distinguish between the phrase “four-fold” in our new framework and that found, e.g., in Buddhist empirical dialectics. In the latter, being of empirical-transformational character at most, there is no trace of essential relationship or logical enclosure with respect to the more contemporary Kantian and Fichtean categories pertaining to “das Ding an sich” (the thing-in-itself). Rather, in that ancient framework, given an object of contemplation *A* belonging to phenomena and subject to process — and ultimately embedded in a universe of infinite contingency regarding the past, present, and future —, the associated dialectical possibilities, of the utmost extent, are: “*A*”, “non-*A*”, “non-non-*A*”, and “none of these”, already (though not sufficiently, as we shall see) in contrast to the more usual forms of binary logic. A roughly tangible example would be the irreversible transformation of water (“*A*”) into milk (“non-*A*”), into vapor (“non-non-*A*”), and into curds (“none of these”), by the process of powdering, mixing, and heating however complete.

Though bearing superficial visceral resemblance with this in the use of the similarly expressed four identifiers, our logical strand is more of ontological “unbracketed” (i.e., non-Husserlian) dialectical nature, and not of mere process-based empiricism, existentialism, and phenomenology (i.e., non-Heideggerian). Rather, we subsume the entire phenomenal world of entification, process, and contingency already in the first and second categories (of “*A*” and “non-*A*”), as we shall see, thus leaving the two last categories as true ontological categories. We assume that the reader is quite familiar with essentially all kinds of dialectical preliminaries, so we shall proceed directly to the new elements of the four-fold analysis we wish to immediately convey here.

In accordance with the ontic-teleological unity given in the preceding section, we keep in mind four major constituents responsible for the presence of definite universal existence, hereafter denoted as the following “eidetic simplex”:

$$\{MO\} : \{S(\text{Suchness}), U(\text{Universe}), N(\text{Monad}), M(\text{Reality})\} + \{\text{phenomenal instances}, O(\text{phenomenal entirety})\},$$

where the first group belongs uniquely to Reality (*M*) and the second is due to empirical-dialectical process-based observation whose phenomenological entirety is denoted by *O*. This representation implies that the identification is made from *M* to *O*, i.e., from Reality to phenomena, yielding a true unitary ontic-teleological state for any given elements of *O*. The analytic union between *M* and *O*, in this case, is none other than the Universe, i.e., *U* as a function of its underlying noetic surjectivity (*g, dg*).

Now, just as *M* is singular and four-fold with respect to the above representation, so is *O*. Due to the union between *M* and *O*, there exist common elements between *M* and *O* possessing true ontological weight: the “within-the-within” element and the “without-the-without” element. In short,

given an arbitrary phenomenal instance A , we can write, according to the underlying representation

$$O = (\text{without, within, within-the-within,} \\ \text{without-the-without}),$$

the following representation:

$$O(A) = (A, \text{non-}A, \text{non-non-}A, \text{none of these}),$$

where we shall simply call the four ontological entries “categories” — for the sake of brevity.

Let us note the following important identifications for the associated elements: given A as an object, there is guaranteed, in the empirical necessity of phenomenological space-time, an entity other than A — in fact a whole range of limitless instances of otherness —, including that which is categorized by traditional Buddhist logic as either “non-non- A ” or “none of these”, especially in the residual sense of a given underlying process, as we have seen. But, in our approach, these two are not yet eidetically qualified and simply exist as part of the infinite contingency of phenomena — and so we can regard A already as both entity and process, without the need to make use of the earlier formalized aspects of Buddhist logical representation. As such, a phenomenal object A has no “inside” other than the entire phenomenal contingency in the form of immediate “otherness” (e.g., any “non- A ”): this, when applied to an arbitrary organic individual, without negating the existence of the extensive world, negates the presence of a non-composite “soul” once and for all (but not the “soul-in-itself” as an eidetically qualified microcosm), which remains true in our deeper context of representation.

Meanwhile, at this point, we shall call the traditionally undecided Kantian categories into existence instead, according to which “non-non- A ” (“without-the-without”) is the entire fluctuative phenomenological set O , which is devoid of absolute individual entification, simply due to the fact that Kantianism is undecided about A -in-itself, yet leaving it there, as it is, in existence. This arises in turn simply because of the inherent Kantian empirical undecidability between pure subjectivity (“spiritism” and “relativism”) and pure objectivity (“material dogmatism”) — alluded to elsewhere in a preceding section.

However, given our ontic-teleological equation, the present theory overcomes such undecidability on the epistemological level of things, including the phenomenological problem of the inconsistency of a singular entity (such as the phenomenal mind and its knowledge and abilities): singular yet still constituted by its inevitable inner multiplicity of reflective objects. It is as follows.

Given, for instance, the classic example of “a leaf falling off a tree in a forest”: does it fall, after all, when there is no one observing it? Our response to this, accordingly, is that it truly depends on what kind of observer is present, i.e., how he is categorically qualified in Reality. Thus, an

arbitrary observer will not qualify as a decisive representation: in that case, the leaf still falls due to, e.g., the law of gravity, for the macroscopic laws of physics are “arbitrarily objective-compulsive” in relation to the arbitrary observer. In other words, such a subjective observer is always objectified (or “subjectified away”) by that which is other than himself, which in this case is the totality of the manifest laws of Nature. Hence, his subjective self is bounded by a kind of temporal self-determined objective dogmatism as well, and if he attempts to be objective, he is soon limited to being subjective enough. In all this, he is composed of fundamental indeterminacy not intrinsically belonging to himself — as approached from the “below limit” —, but which is a surjective determination from the “above limit”, i.e., from the Universe itself.

Rather strikingly, the situation is fundamentally different if the observer is the Universe itself: whether or not the leaf falls, it depends on Noesis, according to the representative constitution of the Universe in our “Reality equation” above. In other words, there exists a so-called “Ultimate Observer” as a “surjective instanton” with respect to the entire Mirror-Universe of reflexivity. Since this observer exists at the self-similar singular ontological level of Suchness, it is again self-singular without parallel and indeed without any logical extraneous qualifier (and quantifier), thereby encompassing the Real, the Mirror, the Image, and the Shadow, in the manner of Reality. In other words, such an observer is none other than Reality, in relation to the Universe. Needless to say, that need not be “Reality-in-itself” in the rough sense of the phrase, despite existing also at the primary ontological level and in limitless eidetic oneness with Reality. Rather, it is most uniquely none other than it — and nothing else is directly (presentially) like such “Non-Otherness” with respect to Reality itself. Respectively, such an observer is noetic, i.e., the essence is of the level of the Surjective Monad, and such identification is already beyond all practical phenomenology even in its extended descriptive form.

Hence, up to the most lucid isomorphism, the “within-the-within/non-non- A ” element of an eidetically qualified entity $\{A\}$ (which, unlike an ordinary entity subject to Buddhist and Kantian dialectics, definitely possesses genuine, empathic inwardness and outwardness) can be identified as none other than the Universe, which in turn is the noumenal A itself, while the corresponding “without-the-without/none-of-these” element as Reality itself, whereas the conventional modes of “within” (A_2) and “without” (A_1) are, respectively, the abstract phenomenological A and the concrete (or material) phenomenological A . Hence the following representation:

$$\{A\} = \{A_1, A_2, U, M\}.$$

A straightforward example of $\{A\}$ is the Universe itself, i.e.,

$$\{\text{Universum}\} = \{\text{the Material Universe, the Abstract Universe, the Universe-in-Itself, Reality}\}.$$

Or, in subtle correspondence with that, we may think of the categorical representation of thought itself, which has no equal parallel among arbitrary phenomena other than what is similar yet other than it (i.e., its possible anti-pod):

$$\{\text{Thought}\} = \{\text{Thought, Anti-Thought, Unthought, Reality}\}.$$

Thus, phenomenally, thought always entails anti-thought: both are two intelligible sides of the same coin on the phenomenological horizon. However, note that such anti-thought is not equivalent to the further eidetically qualified Unthought. Simply speaking, this very Unthought somehow allows not the entirety of phenomena to perceive Reality as thinkable in the first place. In this light, the famous dictum by Descartes, “I think, therefore I am,” is indeed far from complete. The more complete phrasing would be something like: “I think, therefore I am, I am not, I am not-not, and none of these.” And this too, in the face of Reality, would still depend on the eidetic qualification of the one expressing it.

“Away” from all matter and abstract dynamical physical laws, the Universe can thus be identified as a singular surjective-reflexive mirror of “superluminosity” upon which Reality “acts” trans-reflectively through *Noesis* and *Differentia* (especially the qualified infinitesimals), hence the sobriquet “Mirror-Universe” (which is particularly meaningful here, and may or may not be related to the use of the phrase in the description of an exciting geometric structure of the physical Universe as revealed in [8] and based on a chronometrically invariant monad formalism of General Relativity as outlined in [4, 9, 11]). It is said to be “superluminal” in reference to the state of “universal unrest” as measured against all the rest of individual phenomena in the cosmos, somewhat in association with the ever-moving, massless photon as compared to the rest of physical entities (but this is only a gross, fairly illegitimate comparison, as we do not aim at sense-reduction at all).

Other examples include fundamental categories such as space-time, energy, matter, consciousness, etc.

Note that, generally speaking, the abstract phenomenological category (e.g., the concept, instead of the actual stuff, of a tree) is not the same for any entity as the noumenal category. Further, whenever an arbitrary, fluctuative entity $\langle A \rangle$ (without eidetic qualification) is represented according to the above scheme, we should have instead

$$\langle A \rangle = \langle A_1, A_2, \{U\}, \{M\} \rangle,$$

i.e., although $\{U\}$ and $\{M\}$ are present in the above representation, as if being $\langle A \rangle$'s linearly valid components in their respective contingency, $\langle A \rangle$ possesses no universal similarity with $\{U\}$ and $\{M\}$, let alone with just Reality, but only with A_1 and A_2 (subject to phenomenological mapping or transformation) — which is why U and M appear “bracketed away” therein, for otherwise they would best be written as “null

components” (but which in turn would carry us away from its deeper ontological representation).

Finally, as we have seen, our all-comprehensive “Reality equation” (i.e., all the above in a word) is

$$M : N(U(g, dg)) \sim S.$$

And we can say something fundamental about the state of Reality and the Universe as follows:

$$\{MO\} = \text{All-Real } (M \text{ and } O \text{ are Real and Self-Evident}),$$

$$\{OM\} = \text{Ultimately Unreal (leaving Real only } M),$$

$$\{MO\} \neq \{OM\} \text{ (the Reality-condition of asymmetry and anholonomicity),}$$

i.e., the eidetic “distance” (connective foliage) between Reality (M) and Otherness/Phenomena (O) is not the same as that between Otherness/Phenomena (O) and Reality (M) — in part owing to the non-reality of arbitrary phenomena with respect to Reality —, which is why Reality is said to “contain all things, and yet these contain it not”, so long as arbitrariness is the case. In this instance, we may effortlessly witness the generally eidetic, anholonomic, asymmetric connection between categories in the Universe, with respect to Reality. (These categories, in the main, being ontology, epistemology, axiology, and phenomenology.) The word “anholonomic” clearly points to the path-dependence, or more precisely the direction-dependence, of our epistemological consideration: *eidetically, surjectively approaching things from the non-dual ontic-teleological Reality will be substantially different from arbitrarily, phenomenologically approaching Reality from (the transitive state of) things.*

Eidetic symmetry, thus, only holds in an “exotic case” possessed of Qualon, whereby an entity is eidetically qualified, so that it truly bears “resemblance” in “substance” with the Universe and Reality. Ordinary phenomenal symmetry holds in commonsense cases of isomorphism between things in the same category or in extensively parallel categories across boundaries, e.g., between one particle and another in collision, between an actual ball and a geometric sphere, between physics and mathematics, or between language and the world. In this respect, traditional philosophy (as represented chiefly by ontology and epistemology) qualifies itself above such phenomenological parallelism, especially with the very existence of the epistemology of aesthetics, but anyhow remains “infinitely a level lower” than Reality. (Such is in contrast to a famous, epistemologically trivial statement by Stephen Hawking, somewhat in the same line of thinking as some of those working in the area of Artificial Intelligence (AI) or certain self-claimed philosophers who enjoy meddling with “scientists” and “technologists” regarding the current state of science and the eventual fate of humanity, which can

be roughly paraphrased as: “The only problem left in philosophy is the analysis of language,” where the one saying this “intuitively” mistakes post-modernism for the entirety of philosophy. One, then, might be curious as to what he has in store to say about art in general, let alone Being!

It is important to state at this point that the kind of consciousness possessing eidetic-noetic symmetry (with respect to the Universe and Reality) is none other than Genius, or Noesis itself, whose nature we shall exclusively elaborate upon in the last section.

5 The Ultimate Observer in brief

“Who is looking at who? How far away is the Real from the reflection?”

We can very empathically say that the Ultimate Observer is such that if that One stopped observing the Universe by way of Surjection (Surjectivity, *Noesis*), and not only in terms of phenomenological abstract laws and concrete entities, it would all cease to exist at once — at one Now — “before before” and “after after”, noumenally and phenomenally. This, again, is beyond the level of omnijjective reality (omnijjectivity) or conscious surrealism (of “altered consciousness states”) and mere inter-subjectivity, for it is an eidetically qualified noetic determination without parallel and residue.

The respective observer, then, is called a “noetic observer”: he eyes the Universe even before the Universe is “conscious enough to eye him”, with all its noumenal and phenomenal instances, and the Universe takes on *essentia (forma)* only through him. The level of imagination of such an observer, which is equivalent to the very form and interior of the entire Universe, is not as naive thinkers would potentially suggest (with express slogans like “anybody can dream anything into life” and “anything is possible for anyone”): first of all, he is eidetically qualified by Reality as regards his very presence and his observing the Universe. Thus, it cannot be just an arbitrary observer, let alone “consciousness”, in phenomena, and so both typical superficial “science-fiction” and “spiritual pseudo-science” (i.e., “scientific pseudo-spirituality”) ultimately fail at this point, leaving only indeterminate non-universal surrealism.

What has been said of Reality thus far, in the foregoing twice-qualified ontological fashion, has been said enough clearly, exhaustively, and exceptionally. Still, let’s continue to throw some endless surjective light at any of the better-known sciences (such as physics and cosmology) and at the so far little-understood (or completely misunderstood) philosophy of universal aesthetics (i.e., the nature of Genius).

6 On a model of quantum gravity and quantum cosmology: the all-epistemological connection

“Of geometry and motion, however, I must speak, no matter how faint.”

We now wish to briefly review certain aspects of a model of quantum gravity as outlined in [3]. This consideration may be skipped by those interested only in the supra-philosophical aspects of the present exposition. But, as we shall see, there is an intimately profound universal similarity between a primary underlying wave equation there and our “Reality equation” as presented here, elsewhere.

In the truly epistemological dimension of this theory, gravity and electromagnetism are unified by means of constructing a space-time meta-continuum from “scratch”, which allows for the spin of its individual points to arise from first geometric construction and principles, without superficially embedding a variational Lagrangian density in a curved background as well as without first assuming either discreteness or continuity. As a result, we obtain a four-dimensional asymmetric, anholonomic curved space-time geometry possessing curvature, torsion, and asymmetric metricity (generally speaking, the distance between two points A and B , on the fundamentally asymmetric, “multi-planar” manifold, is not the same as that between B and A). The symmetric part of the metric uniquely corresponds to gravity while the anti-symmetric part thereof to electromagnetism (which is a generalized symplectic (pure spin) structure), resulting altogether in a unique, scale-independent spin-curvature sub-structure.

A five-dimensional phase space then exists only in purely geometric fluctuation with respect to the four-dimensional physical manifold, in contrast to regular Kaluza-Klein and string theory approaches. Thus, we do not even assume “quantization”, along with continuity, discreteness, and embeddability.

An important result is that both the gravitational and electromagnetic sectors of the theory are “self-wavy”, and the entire space-time curvature can be uniquely given by the wave function of the Universe for all cosmological scales, serving as a fundamental fluctuative radius for both the monopolar meta-particle and the Universe. Needless to say, here the Universe and such a meta-particle (monopole) are roughly one and the same. Also crucial is the fact that outside matter and electromagnetic sources (as both are uniquely geometrized by the dynamics of torsion in our theory, while in turn the torsion is composed of the dynamics of the anti-symmetric part of the metric responsible for individual spin “kinematicity”), gravity uniquely emerges in an electromagnetic field. Another instance is that both gravity and matter appear therein as “emergent” with respect to the entire geometric quantum fluctuation whose primary nature is electromagnetic.

To cut the story short, our quantum gravitational wave equation is as follows:

$$(DD - R) U(g, dg) = 0,$$

where DD is the generalized (anholonomic) wave-operator — constructed by means of the generalized covariant derivative D_i —, R is the spin-curvature scalar, U is the wave function of the Universe, g is the asymmetric metric, and dg is the

asymmetric metrical variation. In contrast to the “spinless description” of the Klein-Gordon equation of special relativistic quantum mechanics and the originally non-geometric Dirac equation, our wave function U is an intrinsic spin-curvature hypersurface “multivariant” (i.e., the hypersurface characteristic equation) and, upon the emergence of a specific toroidal quantum gravitational geometry, becomes none other than the generator of the most general kind of spherical symmetry (especially useful in the description of particle modes).

A complementary wave equation is also given there in the form of a completely geometric eikonal equation:

$$g^{(ik)}(D_i U)(D_k U) = -RU^2 \longrightarrow 1,$$

which goes over to unity in the case of massive particles (otherwise yielding a null electromagnetic geometry in the case of massless photons), for which

$$R = R(g, dg) \longrightarrow -\frac{1}{U^2}.$$

Among others, such fundamental equations of ours result along with the following comprehensive tensorial expressions:

$$R_{ik} = W^2(U) g_{(ik)} \text{ (for gravity and matter),}$$

$$F_{ik} = 2W(U) g_{[ik]} \text{ (for electromagnetism),}$$

where the operations “()” and “[]” on tensorial indices denote symmetrization and antisymmetrization, respectively, and summation is applied to repeated tensorial indices over all space-time values. Note that the above second-rank spin-curvature tensor, represented by the matrix R_{ik} , consists further of two distinct parts built of a symmetric, holonomic gravitational connection (the usual symmetric connection of General Relativity) and a torsional, anholonomic material connection (a dynamical material spin connection constituting the completely geometrized matter tensor).

The strong epistemological reason why this theory, among our other parallel attempts (see, e.g., the work on the geometrization of Mach’s principle by the introduction of a furthest completely geometrized, chronometric (co-moving) physical cosmic monad as outlined in [10] — and the list of some of the Author’s other works therein), qualifies as a genuine unified field theory and a theory of quantum gravity is that, among others, its equation of motion (namely, the geometric Lorentz equation for the electron moving in a gravitational field) arises naturally from a forceless geodesic motion, that the theory gives a completely geometric energy-momentum tensor of the gravo-electromagnetic field — plus room for the natural emergence of the cosmological term as well as the complete geometrization of the magnetic monopole — and that the theory, without all the previously mentioned ad hoc assumptions (such as the use of arbitrary embedding procedures and the often “elegant” concoction of epistemologically unqualified Lagrangian densities, with non-gravitational field and source terms), naturally yields the

eikonal wave equation of geometric optics, therefore completely encompassing the wave-particle duality: therein a particle is a localized wave of pure spin-curvature geometry. Or to be more explicit: elementary particles, including light itself, propagate with certain chirality (helicity) arising purely geometrically due to individual-point spin and manifold torsion, in two geometric transverse and longitudinal modes (hence the existence of two such completely light-like surface vectors in the case of photons, whereby a photon can be regarded as a null surface of propagation with transverse and longitudinal null normal vectors emanating from it, which is the ground-state of all elementary particles).

In short, the theory yields a completely geometric description of physical fields and fundamental motion for all scales, especially as regards the question: “why is there motion in the Universe, rather than phenomenal stillness?” — which is quite comparable to the generically winding epistemic query: “why is there existence, rather than absolute non-existence?”.

The full extent of this physical theory is not quite an appropriate subject to discuss here, but we will simply leave it to the interested reader for the immediate comparison of our following two equations:

$$(DD - R) U(g, dg) = 0 \text{ (for the phenomenal Universe),}$$

$$M : N(U(g, dg)) \sim S \text{ (for the noumenal Universe),}$$

with respect to the manifest epistemological connection between the noumenal and phenomenal Universes.

Additionally, our model of quantum gravity also reveals why the physical Universe is manifestly four-dimensional, in terms of the above-said generalized symplectic metrical structure, and whether or not the cosmos originates in time (for instance, due to a “big bang” ensuing from the standard classical, homogeneous, non-quantum gravitational model of cosmology) — to which the definite answer now is: it does not, but it can be said to be “emergent” as it is entirely qualified (necessitated), in the ontic-teleological sense, by that which is other than space-time categories, and in this sense the Universe is both preceded and surpassed by Reality and yet, due to Noesis, is never apart from it. As there remain categories of infinities, certain physical-mathematical singularities may locally exist in the fabric of the cosmos rendering the space-time manifold “non-simply connected”, but across such local boundaries the cosmic origin itself cannot truly be said to be (traceable) in time, for the Universe-in-itself is Reality’s “Now-Here”, infinitely prior to, and beyond, the evolutionary and yet also encompassing it.

7 Genius: a conversation with noumena — closure

“That leaf, which silently yellows and falls, is — more than all smothering possibilities — a happening unto itself. If only it were to happen up above instead of down here, among us, the celestial domains would all be terrifyingly cleansed at once.”

We are now at a psychological and intensely personal stage where we can truly speak of the nature of Genius in the solitude of certain unsheltered sentiments and unearthed fissures belonging to the individual who sees the longest evening all alone, to which he lends all of his insight. That, he verily sees not outside the window, but entirely in himself. The only helplessly beautiful solace he has, then, arises simply from his soul seeing things this way. By “soul”, we mean that which moves from the pre-reflexive Subject to the reflexive realms as none other than the microcosm, such that others can hardly notice that he is happening to the Universe as much as the Universe is happening to him.

Weren't Genius synonymous with Infinity — while in the synoptic world of countless impalpable beings, like a contrasting taciturn ghost, he is often an infinitely stray, perpetually long personification (acute inwardness) of the noumenal world along outwardly paradoxical, tragic banishing slopes —, Kierkegaard would not have swiftly declared,

“The case with most men is that they go out into life with one or another accidental characteristic of personality of which they say, ‘Well, this is the way I am. I cannot do otherwise.’ Then the world gets to work on them and thus the majority of men are ground into conformity. In each generation a small part cling to their ‘I cannot do otherwise’ and lose their minds. Finally there are a very few in each generation who in spite of all life’s terrors cling with more and more inwardness to this ‘I cannot do otherwise’. They are the Geniuses. Their ‘I cannot do otherwise’ is an infinite thought, for if one were to cling firmly to a finite thought, he would lose his mind.”

Similarly, Weininger is known to have exclaimed,

“The age does not create the Genius it requires. The Genius is not the product of his age, is not to be explained by it, and we do him no honor if we attempt to account for him by it... And as the causes of its appearance do not lie in any one age, so also the consequences are not limited by time. The achievements of Genius live forever, and time cannot change them. By his works a man of Genius is granted immortality on the Earth, and thus in a three-fold manner he has transcended time. His universal comprehension and memory forbid the annihilation of his experiences with the passing of the moment in which each occurred; his birth is independent of his age, and his work never dies.”

(For more such non-dissipating, spectacular universal overtures, see [6].)

Peculiar to Genius is, among other solitary things, an infinite capability for intricate pain (inward ailment), for perpetual angst, which people often misrepresent as arising from mere anti-social loneliness or lack of amusement. But this aspect of Genius cannot be partitioned arbitrarily from the

soaring spontaneity of his infinite ecstasy. Rather, Genius is simply beyond ecstasy and despondence, as well as beyond pride and self-deprecation, the way people are used to these terms. In any case, it is a state of universal sensitivity, inspiration, solitude, and creativity, which is the Eye of Creation, whereby Reality is comprehensively “likened” to a form ensuing from Noesis.

This way, most people are mistaken in their belief that Genius and talent are equivalent, for Genius is, indeed, “separated from all else by an entire world, that of noumena”, and not situated “within the spectrum of all linearly predictable expectations and contingencies”, as Goethe, Schopenhauer, Wilde, Emerson, Weininger, and Wittgenstein would have agreed. Mere belief, assumption, or syllogism is effortlessly devoid of authentic realization, let alone Reality: it is not even worthy of the simplest meta-logical refutation.

Indeed, Genius is in no way the superlative of talent. Talent is, at most, phenomenal-reflective, while Genius is noumenal-surjective and noumenal-reflective. It has been said that Genius does not act as a role model for talent at all: with respect to the latter, the former may appear inane, murky and most wasted, simply because the latter lacks that which is infinitely other than the entire contingency of multiple reflections and projections.

The world of Genius is Moment, Universality, and Creation, where the entirety of noumena is revealed to the persona without residue, which is the greatest, most absolute kudos in existence, be it in the presence or absence of an audience. The world of talent is ordinary — no matter how augmented — time, space, and imitation, i.e., the relative integral power of the inter-subjective contingency and tautology of phenomenal recognition and security.

The ocean of Genius is the heaviest self-necessity of greatly spontaneous assaults and pervasions on any shore without sparing both any large accidental object and a single grain of sand: it evokes creation and destruction entirely in its own being in this world. The pond of talent, amidst dregs, is the relative confidence of “sedimental measurement and experimentation”, albeit still related to intensity.

The intentionality of Genius is a self-reserved “Parsifal” of Universality, while that of talent is always other than the thing-in-itself (and so, for instance, a talent associated with science tends not to embrace the essence of science itself, which is one with the essence of creative art and epistemic philosophy, but only something of populistic, tautological “scientism”).

The essence of Genius is Reality, not just situational “truth” — not the normative, often progressive, collective truths of talent and society.

The way of Genius in the world is traceless originality and thus defies all sense of imitation and expectation. Who shall discover the traces of fish in water and those of birds in the sky? And yet, this matter of Genius is more than that: he is different from all similarities and differences, absolutely

independent of representation. Hence it is said of men of Genius — for instance by Weininger — that “their parents, siblings, and cousins cannot tell you anything about them, for they simply have no mediational peers, no genial otherness”. By contrast, talent is still psychogenetically and methodologically inheritable.

The life of Genius is that of utter sensitivity, and not just volitional silence and loudness. It is one of transcendental consciousness and intensity, and not constituted of mere choice and chance.

As the hallmark of the Genius is authenticity and creativity, which is not situated within the rhyme and rhythm of a mere choice of life-styles, he can do no other than this, and no one needs to tell or teach him anything.

Individuals of Genius exist as universal gradations of the pure eidetic plenum, and not as part of the mere ascending levels of talent. Thus, the particularity of Genius is always simultaneously universal: it is both twice-qualified “*Atom*” and “*Platon*”, Instanton and Soliton. He possesses the entirety of Object, Subject, Dimension, and Surject to unbelievable lengths.

Indeed, as has been generically said: “science becomes pure imagination, art pure life, and philosophy pure creation”, there in the vicinity of Genius.

Genius is Michelangelo, not Rafaelo. Genius is Leonardo, not rhetoric. Genius is Mozart, not the Royal Court. Genius is Beethoven, not the audience and merely connected hearing. Genius is Zola, not psychotherapy. Genius is Kafka, not stability. Genius is Rembrandt, not feminism. Genius is Tolstoy, not chastisement. Genius is Johann Sebastian, not the Bach family. Genius is Klimt, not neurasthenics and Venus. Genius is van Gogh, not art exhibitionism. Genius is Glinka and Gould, not musical recording. Genius is Abel and Galois, not the Parisian Academy. Genius is Kierkegaard, not Hegelianism. Genius is Weininger, not Aryanism. Genius is Wittgenstein, not philology. Genius is Kant, Einstein, and Zelmanov, not the herd of “scientism”. Genius is Goethe, not Prussia. Genius is Cezanne, not Europe. Genius is Emerson, not America. Genius is Neruda, not Chile. Genius is Tagore, not India.

Genius is the Renaissance in motion before everyone else is capable of naming it, not its “timely and subsequent crumbs”. Genius is Dream, not sleep. Genius is Insight, not the day. Genius is Vision, not a report or a documentary. Genius is the austere summit, not the floating clouds. Genius is the ocean, not a river. Genius is gold, not the muddy colliery, not the mining. Genius is youth, not childhood, not adolescence, not adulthood, and absolutely not old age. Genius is all-life, not imitation. Genius is all-death, not barren constancy and consistency. Genius is acutely conscious suicide, not helplessness — but definitely not all suicides are Genius. Genius is love, not crude relationship. Genius is music, not licensed instrumentation. Genius is Self, not super-tautological composition. Genius is sheer nostalgia, not learning. Genius

is Creation, not school, not training.

Genius is the cold North Atlantic, not the luxurious Titanic. Genius is the Siberian currents, not the avoidance of winter for more festive humidity. Genius is the entire Sonora, not urban life of chance-fragments. Genius is character, not yielding sexuality. Genius is Moment, not societal time. Genius is Mystery, not public space. Genius is Memory, not standard coordination. Genius is Nature, not information — and so not recognition. Genius is the full eclipse as it is, not prediction. Genius is the entire night, not a system.

Genius is Motion-in-itself, not a planned sequence. Genius is real individuality in the Universe, not composite institutional, societal, cultural pride. Genius is the singular conquest, not an artificial war. Genius is the universal meteor, not a celebratory fire-cracker. Genius is the rareness of a tsunami, a volcano, or an earthquake, not reported abrupt casualties. Genius is solitude, not sold and given democracy, and not a republic. Genius is the abyss and the sudden voice and force arising from it, not typical antiquity, Victorianism, and post-modernism.

Genius is the Universe, not a specific age of trends, not a destined place of people.

Genius is Reality, not a situation, not an option, not a collection of societal facts.

Genius is Genius, not talent.

Genius is a word not yet spoken (enough) by other sentient beings. And, respectively, a drop not yet consumed, a meaning not yet sighed, a clarity not yet impregnated. A birth not yet celebrated, a sudden electricity not yet channeled, a humanity not yet recognized.

Often, in relation to tragedy, Genius emerges as a funeral song, preceding all births and surpassing all deaths, which people find hard to canonize. Amidst their superficial merriment, a man of Genius is like the night that falls on their eyes and sinks in their souls — to be forgotten at their selfish ease. He is the loneliness of the day on a deep cogitator’s pane, one with the blue nacre of things.

Why then would Genius be most exclusively, among others, associated with tragedy? It is because most people would not mind partaking of “joy as it is”, with or without anticipation and as much and gauche as possible, yet they are ever impotent and apprehensive when it comes to facing “the other thing as it is”, i.e., tragedy. As Genius is the only spontaneous genera capable of infinitely imbibing the noumenal “thing-in-itself”, in universality and in particularity, in representation and in person, a man of Genius would principally never shun tragedy. His objective is inevitably the surjective pure intimation of it.

Thus, tragedy has sought the Genius even from before the dawning of the world. Indeed, he would even volunteer for it. And the entire Universe volunteers for it too, in and through his very individuality. This is why, the theme of tragedy (or death) is rather universal: it is consciously frequented only by very few men and yet by the entire Universe

itself. These men, without losing their Self, which is Reality and the Universe — unlike the way most people understand it —, embrace phenomenal selflessness and defenselessness with full noumenal understanding and bursting innocence: they are “too close” to the torrents of the most unlikely visitation of kisses, “too close” to thunder in the heavy rain, “too close” to the Sun in elevation and peaking radiation, “too close” to the soil and dust in every heavenly intimation, “too close” to the nakedness of Nature in everything raw and full, “too close” to the chiseled understanding of certain winter-banished seeds and underground grains, “too close” to the Cornelian female breast of surreptitiously migrating strengths and silences. They are “too close” to their own prodigious male latitude, in their expensive self-immolating Siriusian nuclear moods, eventually being poured out of life onto the canvas of death as the most splendid of selfless, will-less, unadulterated presence of colors and paintings, while thus rendering themselves too far from incidental admirers other than Reality itself. Such is glory: only due to that does deeply crimson compassion whiten in this world for a few sensitive others to see.

Though this world may see naught but sad wrinkles, the love of Genius is strong in its own unseen furrows, at the core of stars, in the fire of molten things. Genius is strong though weak and peevish in appearance: it is exalted in everything that takes roots and bears its own growth, in everything universal Reality wishes to see for itself. The Crucified is such a rare taste in people’s veins to devour. So either they unveil their own souls in the tragedy of Genius and then die to live anew, or live the life of a heathen forever.

When will this world fall into indigenous silence, like Genius, but not in certain sleep? Where is the soft hand of a lovely, caring female weaver upon Genius’ crushed, blackening fingers emerging from the rugged Earth and its ravines? In an aspect that relates the solitude of Genius and the continuity of mankind, known and unknown Geniuses have been digging the Earth for eons, for this world’s most conscious dreams, so that humanity may gush out with Nature’s own blood of youth: such is done among tormenting rocks, yet in order to reach above the Sun — yes, with the entire humanity.

Who would glue his petty, cowardly self to the secret, yet infinitely open, wounds of Genius? Either humanity caresses Genius the way Genius would touch humanity, until nerves, whips, and scourges become impalpable in humanity’s constitution of clay and fire, and of some might of the Unknown, or it perishes altogether with self-sufficient Genius not repeating itself for its cause ever again.

And to humanity it will then be said, “Either gaze at the red branches in the park of lovers, where Genius lives and dies unnoticed, where life fills its own cup through entwined hearts, lips, and arms through the sacrificial life of Genius at unseen roots, or, perchance, seek another countenance, another reality altogether and die without Reality ever sketching you in its own bosom.”

In this savage world of heavily fabricated walls, who then would want to taste a most tender, fateful wet drop of dew and honey oozing from the pristine skin of Genius, in the rain of tragedy and in the weft of huge solitude, which might just taste like the Universe — all of the Universe?

Who, then, would be able to recapture the moments of Genius, once they pass for good? Would they ever be able to simply rediscover the soul of Genius among many roots, thorns, and tremors and still multiply the silent understanding of love and life that hides in a wide ocean that shall never want to depart from humanity?

Who, then, would abandon the ever-putrefying cowardice, soulless collectivism, and mere conformity with much of this unconscious world and sit with Genius just for one more night — where there shall be no more secrets in the darkness’ midst, other than shadowless man, without flight from destiny, naked, engraved, and unshaken on the scarlet horizon behind a thousand prison features? Who shall be loved and sought by freedom this way?

Genius is a most shunned resonance behind all languages: both “knowing” and “not knowing” recognize it not. Whereas people are sole humans, a man of Genius is, infinitely more acutely, the most solely human: he is the one who understands love and sacrifice the most, who breathes limitlessly upon the flanks of wild flowers and hidden rivulets, yet no one among sole humans dares to love him with enough vastness of space. Indeed, he is the drops and substances in the rain, all the non-existence in dust.

When an individual of Genius desires existence in this world, he comes yielding against everyone else’s direction, cutting the evening on its very edges, unfolding horizons — even if that means undoing fancy rainbows. And when he yearns for an ultimate self-exile, he rushes towards death unconditionally, just as he once arrived in this world not by slow walking, purblind wandering, and empty gazing, but by the crackling spontaneity that impulsively and immeasurably forms fateful symmetries through the soul’s pure motion.

The life of Genius leaves this world a silent place underground for the most solitary and distinguished of understanding, knowledge, tenderness, and pain. Only a few, therefore, know what a “most original Genius” truly means. If only people knew the universal responsibility set upon the shoulders of Genius, and not just its apparent glories, very few of them would dare to aspire to the rank of Genius. Instead, they would be fairly content with talent alone. For, in relation to humanity as a “non-ideal savior”, Genius lives with such a palpitating, lonely chest and uplifting sensitivity in the narrowness of time’s remaining passage. (As Schopenhauer once declared, “*Great minds are related to the brief span of time during which they live as great buildings are to a little square in which they stand: you cannot see them in all their magnitude because you are standing too close to them.*”)

As regards the history of indifference and war that has befallen mankind, the heavens, some say, can’t be errant. But

what idea do they have of a man of Genius whose heart of immense autumns is like a shattered clock, which he hears ticking mercilessly every second until its near cease, even when its fire — of awakening blood — moves from his heart's solitude, to his soul's labyrinth, to his lips, to the desire to possess, to nearness, to excitement, to the redemption of humanity? When the only place he can carry humanity to — for the moments and lost wings to take, to hold, to secure — is his ship of winter, passing through wounding seas, violent winds, and threshing floors? When he himself is one of the branches of the long, solitary night — of azure fate — and hardly a resting place for another soul's existence?

A man of Genius loves humanity beyond its occasional self-pity and vain arrogance, without knowing how to carry the luster and growth of the garden of passion and intimacy elsewhere other than through the often awkward abruptness and intensity of each second. And so, wordlessly, certain hidden things are written in blood and yet shared in moisture, freely given and fully experienced — just as the cup, potion, and tavern are spun only at night — even while personal hope, let alone a future, ever shies away for himself, for soon enough nearly everyone's eyes are to shut at length in sleep, not knowing that Reality itself is present in the darkest ravine of their modulations.

Men of Genius do not cross poignant, dark reefs to merely taste the deeps of depravity for themselves, but to make contact with the entirety of humanity and to love the unconsciously tragic as it is. But, of conversing with the severity and weather of naked love in the most drenching downpour of sentiments, who shall readily repay these men by communing in their names, even without having seen them?

Who, then, can cover the perimeter of Genius like a pure ring? In the Genius, life passes in a single heartbeat, and he happens to the world like the grip of the strangest spontaneous intimacy upon the furthest comprehension of sincere lovers. The nakedness of Genius is just as day and night are inseparably present in the world, unveiling each other — and thus essentially beating in each other — more than just taking turns and partaking of chance.

Verily, before the whole world of people ever does it, Genius is the poetry that immediately captures the high flares of every joy and the disconcerting depths of every tragedy there has ever been and will ever be so long as humanity exists. By the very personification of Genius is the most distant fate of humanity drawn near and the nearest pitfalls thereof redeemed.

People do the Genius absolutely no honor by merely projecting phenomenal attributes and expectations — and by merely scholastically and naively reflecting — upon him. When, coincidentally, certain men of Genius happen to be situated in certain domains of the society (instead of living in relative obscurity and epistemic solitude), which is a very rare case, it is to be understood that a zoo that proudly keeps a lion or a falcon, has no way of knowing whether or not

it fully possesses it; and yet too often the zoo honors the beast and prides itself in the act only in order to praise itself. Genius exists independently of such a contingency and tautology. The entire gist of societal-phenomenal intentionality approaches not the abyss of the Genius, who, alone, is the monad, center, mind, and heart of the Universe. He is the entirely unabridged, naked pulse of Nature. It is the Genius who merely not “eyes the abyss” and “is conversant with it”, but who also exists there with absolute self-certainty, independently of all the objects outside the abyss (out there in the world), and independently of the entire abyss itself. He is not a mere philosopher of “mereology” either. He never has the need to question his own existence nor to “unveil himself”, whatsoever. He is not a mystic in this sense (and in that of Wittgenstein): it is not mysticism that is mystical, it is the way things already are in and of his nature; yet this he often projects onto people as “mysticism” in order to be “roughly understood”, i.e., when forced to speak to the world.

Indeed, Genius is more of the Universal Mind that establishes (and not just imparts to others) the “Suchness” of the Universe entirely through itself and moves things that way from the infinite past to the infinite future, through the infinite moment, instead of just a mere saint and mystic who has to find his way, by following the ways of other adepts, in much of the Unknown. It is the Pure Sword that still glitters and functions (i.e., moves) in the darkest stretch of space, with or without the presence of mirrors and lights. And it is not just a spark, nor a mere brilliance: Genius is the wholeness of unique illumination and pure presence.

The Universe of Genius individuality is four-fold, encompassing an infinite amount of noumenal uniqueness (not just “totality”) and a most extensive category of phenomenal modes of existence. Thus, again, it contains:

- Reality: *Eidos-Nous* — the Surjective Monad, Absolute Unique Singularity,
- The Mirror-Universe — the Reflective Whole, Singularity, Transcendence,
- The Imagery-World — the Projective Particularity, Multiplicity, Immanence,
- Unreality — the Absolute Darkness

i.e., its being-there, entirely in the greatest genus of individuation, is essentially without chance and residue.

The man of Genius, as such, needs no “belief” nor “hypothesis”, nor even any “transcendental method”, be it of religious, philosophical, or scientific dialectical nature, for he, the Eye-Content of Infinity and the Sign-Severity of Oneness, is he whose essence is All-in-All, the All-One, the Unique: “within”, “without”, “within-the-within”, and “without-the-without”. And this is more than just saying that his individual entification is the microcosm — and that he is a particularization of the Universe.

Unlike a mere saint who is the ultimate phenomenal (linear, diametrical) opposite of a mere criminal, a person of Ge-

nius possesses *Animus* (*Anima*, “animate animal”), with respect to the entire Imagery-World, and is therefore the most unpredictable, spontaneous, intense, and creative in his phenomenal actions, beyond the entirety of collective anthropomorphic morality, if not ethics. And, unlike a mere criminal who is the phenomenal opposite of a mere saint, Genius is fully, intrinsically possessed of Noesis. Thus, a single moment of Genius in the Universe enriches existences infinitely, whether the individual is “animal-like” (in terms of instinct, but not merely psycho-pathological: for instance, even when madness seems to have befallen a man of Genius — as Atlas is said to excessively bear the world on his shoulders, alone, more than any other —, it is so without the Genius losing his persona at all, for his essence is absolutely non-composite Individuality and Universality, inwardly and outwardly; madness is a mere “surrealism” the Genius deliberately embraces in order to relatively, specifically “seal” his suffering without ulterior motives other than “inward romanticizing” (for instance, Goethe and Kafka), and the same can be said about the case of a suicidal Genius) of tragedy-in-itself, or whether he is deliberately an entirely new humanity — and, again, not just a new species — beyond the external world’s understanding.

The Genius is he who knows the saint more than the saint knows himself, and he who knows the devil more than the devil knows himself: needless to say, he definitely knows Kant better than Kant knows himself (indeed, he who understands Kant, goes beyond him and thereby “bedevils” him, while most others are stuck, without soul, in mere scholastic documentaries on Kantianism). Whether or not he speaks of what people call “morality”, it is entirely up to him: in any case, he alone personifies Reality and gives its most elusive aspects to his subjects. Unlike the sadist, he suffers not from the outward surreal vacuum of space and, unlike the masochist, from the inward intimidation of time (again, see Weininger’s psychological essay on aspects of sadism and masochism in [6]). His deliberate transgression of established, normative mores is equally non-understandable by most sentient beings as his infinite capacity for tenderness and selflessness. In any of these acts, he truly owns his moments, either by throwing universal light into utter darkness or by annihilating even light in every phenomenal perception. In one respect, he is indeed ageless Momentum: he is child-like, though not exactly a child, and he is sage-like, though not exactly a sage.

As the Genius is he who phenomenally contains the most variegated manifold of attributes, names, and characters, he thus has to represent an entirely new genus of humanity, a whole new epoch in the evolution of the cosmos, beyond the level of acceptance of present humanity. He remains human, simultaneously aloft as the sky — proud as a mountain — and fragile as the sand of time — humbled as a valley — beyond mere acceptance and refusal, and even beyond contemplation. Just as the heavens send down the rain just as much as they reflect sunlight, and just as the great ocean gently inti-

mates sand-grains and yet annihilates shores and settlements, so is Genius the one most capable of sorrow and joy; rage and calmness; destruction and creation — of both infinitely romanticizing and molding the modes of existence.

Thus, while there can be countless linearly, smoothly predictable talented, institutionalized people in the world, “who are just happy and successful enough” without the tinctures of tragedy and without possessing the Surjective Monad of Genius, there is indeed no Genius without a trait of tragedy, for tragedy is the only melodrama in the Universe used as a language to convey and gather known and unknown multitudes: it is a forceful communication among breaths made possible in a largely superficial world and in a truly secluded corner of the Universe — however with the possibility of communication across it. Of this universal epistemic disposition, the Genius would rather embrace moments of melancholia and quiver like certain autumnal sitar-strings, than be merely happy. Again, while not being a merely fateful one, he never shuns tragedy: he voluntarily internalizes any tragedy (especially the tragedy of other men of Genius, whether known or unknown) and still gives it a breathing space and pulse in the Universe (and indeed binds it as a cosmic episode), when most people are wary of it. Nor does the Genius withhold conquest merely for the sake of mercy. He is the virtuoso, and not just the actor. He is also at once the script, the stage, the spectator, and the actor — the very life of the play. In the cosmic sense of the ultimate unification of observers and observables, he is self-observed, self-observing, self-existent.

As such, the following can be said about the dominion and nature of Genius, which belongs to no school and species at all. An individual of Genius is entirely his very own genus, more than a species, of Universality: without him, the Universe is not the Universe, and Reality would never “act upon itself” and “beget an archetype”. No one can teach Genius anything. No school, nor training, nor erudition can beget, let alone produce, the conscious existence of Genius. Its meta-human dominion is that of non-composite Self-Will animating the infinitesimals (i.e., meta-particulars) of the Universe. Its person is the one most capable of infinite self-differentiation (besides his intrinsic, immutable uniqueness), precisely because the Universe — the infinite Memory (Holography), Moment (Presence), and Mystery (Precedence) — is never exhausted when it comes differentiation, especially self-distinction.

Genius is the very vein and veil of Nature. Once people of discernment and reflection witness the Genius’ unfolding the heavens by climbing them up, at once they shall also witness that he has no ladder nor means, that he is the creator of even the Unknown and of perceptual noema. Or even if at first it appears to them that the Genius uses a ladder or means (such as any transcendental logical method of deduction or any style of art), it will entirely fall back upon themselves after being self-thrown, at them and away from him, by himself, and there is no fear in the Genius regarding this, for, again, he

is everywhere Reality's exception just as Reality is his exception. His sheer independence is the sine qua non of existence.

Thus, where are the kisses to leap towards the solitude of Genius, to consume it for last? Hidden in the pure seethe of an ocean's changeless soul, the love of Genius for the Real and the Human is hardly reachable. Even if Genius appears in the faintest human form, among other things in the perpetual sand of existence, people still find it unreasonable to intimate it. Instead, they readily besiege and confine its very incarnation into disappearance, ridicule by ridicule, betrayal by betrayal, kiss by kiss. But they can imprison not the most invisible, most infinitesimal — the most artful grain (meta-particle) in the Universe. Like unknown butterflies and fresh grapes, however short-lived, the Genius swiftly takes for farewell upon the eyelids of beauty, coming home not any later at the coronet noon of that which has communed with him in existence and appearance.

Only Genius knows Genius, and this is no sentimental exaggeration — whether the inter-subjective world of people (not the world-in-itself) is awake or asleep, it is bound to be troubled by the very person. Indeed, for most, "he draws near from farness, and he draws far from nearness", with respect to perception and non-perception, by the very essence and form of Reality — and Unreality —, for the distance between Genius and people is not the same as that between people and Genius.

Footnote

Suggested parallel reading in philosophy, psychology, mathematics, and physics, especially for the sake of the reader's perspicacity of the present novel epistemological (meta-logical) work in simple comparison with other works dealing with theories of Reality and the Universe.

Submitted on February 29, 2012 / Accepted on March 03, 2012

References

1. Velmans M. Reflexive Monism. *Journal of Consciousness Studies*, 2008, v. 15(2), 5–50.
2. Langan C. The Cognitive-Theoretic Model of the Universe: A New Kind of Reality Theory. <http://www.ctmu.net>
3. Suhendro I. Spin-Curvature and the Unification of Fields in a Twisted Space. Svenska fysikarkivet, Stockholm, 2008 (original doctorate thesis version, 2004).
4. Zelmanov A. L. Orthometric form of monad formalism and its relations to chronometric and kinematic invariants. *Doklady Acad. Nauk USSR*, 1976, v. 227(1), 78–81.
5. Wittgenstein L. *Tractatus Logico-Philosophicus*. (The original draft), 1918.
6. Weininger O. *Sex and Character (Geschlecht und Charakter)*. Wilhelm Braumüller, Leipzig and Vienna 1913 (modern online edition with interlinear translation by Robert Willis, 2004). See also Kevin Solway's splinter page: <http://www.theabsolute.net/minefield/genqtpg.html>
7. Mao L. F. Smarandache Multi-Space Theory. Post-doctoral research report, the Chinese Academy of Sciences, 2006.
8. Borissova L. and Rabounski D. *Fields, Vacuum, and the Mirror Universe*. Svenska fysikarkivet, Stockholm, 2009.
9. Zelmanov A. L. Chronometric invariants and comoving coordinates in the general relativity theory. *Doklady Acad. Nauk USSR*, 1956, v. 107(6), 815–818.
10. Suhendro I. A hydrodynamical geometrization of matter and chronometricity in General Relativity. *The Abraham Zelmanov Journal*, 2010, v. 3, 102–120.
11. Zelmanov A. L. *Chronometric Invariants — On Deformations and the Curvature of Accompanying Space*. Sternberg Astronomical Institute, Moscow, 1944 (published as Zelmanov A. L. *Chronometric Invariants — On Deformations and the Curvature of Accompanying Space*. American Research Press, 2006).
12. Shnoll S. E. *Cosmophysical Factors in Random Processes*. Svenska fysikarkivet, Stockholm, 2009.

Macro-Analogies and Gravitation in the Micro-World: Further Elaboration of Wheeler's Model of Geometrodynamics

Anatoly V. Belyakov

E-mail: belyakov.lih@gmail.com

The proposed model is based on Wheeler's geometrodynamics of fluctuating topology and its further elaboration based on new macro-analogies. Micro-particles are considered here as particular oscillating deformations or turbulent structures in non-unitary coherent two-dimensional surfaces. The model uses analogies of the macro-world, includes into consideration gravitational forces and surmises the existence of closed structures, based on the equilibrium of magnetic and gravitational forces, thereby supplementing the Standard Model. This model has perfect inner logic. The following phenomena and notions are thus explained or interpreted: the existence of three generations of elementary particles, quark-confinement, "Zitterbewegung", and supersymmetry. Masses of leptons and quarks are expressed through fundamental constants and calculated in the first approximation. The other parameters — such as the ratio among masses of the proton, neutron and electron, size of the proton, its magnetic moment, the gravitational constant, the semi-decay time of the neutron, the boundary energy of the beta-decay — are determined with enough precision.

The world . . . is created from nothing,
provided the structure . . .

P. Davies

1 Introduction

The Standard Model of fundamental interactions (SM) is a result of the attempts of thousands of researches in the course of decades. This model thus bears rather complicated mathematical techniques which hide the physical meaning of the phenomena.

Is this process inevitable? And also: can further mathematical details make the Standard Model able to explain virtually everything that takes place in the micro-world? May it be necessary to add SM by the concept proceeding not from electrodynamics? This problem statement is grounded, because another adequate model allows us to consider micro-phenomena from another side, and so it remains accessible for more number researchers.

According to contemporary statements, objects of the micro-world cannot be adequately described by means of images and analogies of the surrounding macro-world. But certain analogies successfully interpreting phenomena of the micro-world and explaining their physical essence exist. It will be shown further in the present exposition.

This work uses conceptualization of another class of physical phenomena, and its possibilities are demonstrated. This model has the inner logic which does not contradict confirmed aspects of SM. Besides, it explains some problems which are not solved at the present time.

It is necessary to outline a survey illustration of our model worked out in the spirit of Wheeler's geometrodynamics. The logic of the model, and its adequacy, is justified by many

examples. Thus another approach towards understanding micro-phenomena is proposed. Herein, straightforward numerical results are obtained only on the basis of the laws of conservation of energy, charge and spin, and evident relations between fundamental constants, without any additional coefficients. These results, being the basic points of this model, justify the model's correctness.

The geometrization of the physics assumes the interpretation of micro-phenomena by topological images. Many such works have been outlined now: for example, the original elements of the micro-world, from which particles are constructed according to Yershov's model [1], are preons, which are, generally speaking, local singularities.

Wheeler's idea of fluctuating topology is used here as an original model of a micro-element of matter: in particular, electric charges are considered therein as singular points located at a surface and connected to each other through "worm-holes" or vortex current tubes of the input-output kind in an additional direction, thus forming a closed contour.

A surface can be two-dimensional, but fractal, topologically non-unitary coherent at that time. It can consist of vortex tubes linkage which form the three-dimensional structure as a whole.

This paper follows [3], where numerical values of the electric charge and radiation constants were obtained. It is shown in [3] that from the purely mechanistic point of view the so-called *charge* only manifests the degree of the non-equilibrium state of physical vacuum; it is proportional to the momentum of physical vacuum in its motion along the contour of the vortical current tube. Respectively, the spin is proportional to the angular momentum of the physical vacuum with respect to the longitudinal axis of the contour, while the

magnetic interaction of the conductors is analogous to the forces acting among the current tubes.

The electric constant in the framework of the model is a linear density of the vortex tube:

$$\varepsilon_0 = \frac{m_e}{r_e} = 3.233 \times 10^{-16} \text{ kg/m}, \quad (1)$$

and the value of *inverse magnetic constant* is associated with a centrifugal force:

$$\frac{1}{\mu_0} = c^2 \varepsilon_0 = 29.06 \text{ n} \quad (2)$$

appearing by the rotation of a vortex tube of the mass m_e and of the radius r_e with the light velocity c . This force is equivalent to the force acting between two elementary charges by the given radius. Note that Daywitt has obtained analogous results in [4].

One must not be surprised that the electrical charge has dimension of impulse. Moreover, only the number of electric charges z is meaningful for the force of electrical and magnetic interaction, but not the dimension of a unit charge. So, for example, the Coulomb formula takes the form:

$$F_e = \frac{z_1 z_2}{\mu_0 r^2} \quad (3)$$

where r is the relative distance between the charges expressed in the units of r_e .

The co-called standard proton-electron contour intersecting the surface at the points p^+ and p^- is considered in [3] and in further papers. The total kinetic energy of this contour equals the energy limit of the electron. Possibilities of the model explaining different phenomena of the micro-world are considered with the help of this standard contour.

2 On the connection between the electric and the weak interactions

The electric and weak interactions are united in the uniform contour. The form of our model continuum in a neighborhood of a particle is similar to the surface of a hyperboloid. It is conditionally possible to separate the contour into two regions: the proper surface of the region (the region X) and the "branches", or vortex tubes (the region Y), as shown Fig. 1. A perturbation between charged particles along the surface X is transmitted at light velocity in the form of a transverse surface wave, i.e. the electromagnetic wave. The perturbation along vortex tubes by Y spreads in the form of a longitudinal wave with the same velocity of transmission, as it will be shown.

Express the light velocity from (1) as:

$$c = \sqrt{\frac{s}{\varepsilon_0}} \sqrt{\frac{1}{s\mu_0}} \quad (4)$$

where s is some section, for instance, the section of the vortex tube. Upon dimensional analysis, the first factor is a specific

volume, the second — a pressure. In other words, this formula coincides with the expression of the local velocity of sound inside continuous medium. It is interpreted in this case as the velocity of the longitudinal wave along the tube of the contour. The longitudinal wave transforms into the transverse surface wave from the viewpoint of an outer observer at the boundary of the X - and Y -regions.

According to [3], the mass of the contour is given by $M = c_0^{2/3} m_e = 4.48 \times 10^5 m_e$. This value equals approximately the *summary mass of W, Z -bosons* (the dimensionless light velocity $c_0 = \frac{c}{[\text{m/sec}]}$ is introduced here). One can state therefore that the vortex current tube is formed by three vortex threads rotating around the principal longitudinal axis. These threads are finite structures. They possess, by necessity, the right and left rotation; the last thread (it is evidently double one) possesses summary null rotation. These threads can be associated with vector bosons W^+, W^-, Z^0 which are considered as true elementary particles as well as the photon, electron and neutrino.

This structure is confirmed by three-jet processes observed by high energies — the appearance of three hadron streams by the heavy Y -particle decay and by the electron and positron annihilation. The dates about detection of three-zone structure of really electron exist [5].

Other parameters of the weak interaction correspond to the given model. So, the projective angle is an addition to the *Weinberg angle of mixing* q_w of the weak interaction. The projective angle is determined in [3] as $\arcsin \frac{c_0^{1/6}}{\sqrt{2\pi a}} = 61.8^\circ$, where a is inverse to the fine structure constant. The value $\sin^2 q_w = 0.231$ is determined experimentally, i.e. $q_w = 28.7^\circ$ and $\frac{\pi}{2} - q_w = 61.3^\circ$. Based exactly on the value of this angle the electric charge is calculated precisely, the numerical value of which has the form [3]:

$$e_0 = m_e c_0^{4/3} \cos q_w \times [\text{m/sec}] = 1.603 \times 10^{-19} \text{ kg m/sec}. \quad (5)$$

3 Fermions and bosons

It is necessary to note that vortex structures are stable in this case if they are leaned on the boundary of phase division, i.e. on the two-dimensional surface.

The most close analogy to this model, in the scale of our world, could be *surfaces of ideal liquid*, vortical structures in it and subsequent interaction between them, forming both relief of the surface and sub-surface structures.

Vortex formations in the liquid can stay in two extreme forms — the vortex *at the surface* of radius r_x along the X -axis (let it be the analog of a fermion of the mass m_x) and the vortical current tube *under the surface* of the angular velocity ν , the radius r_y and the length l_y along the Y -axis (let it be the analog of a boson of the mass m_y). These structures oscillate inside a real medium, passing through one another (forming an oscillation of oscillations). Probably, fermions conserve their boson counterpart with half spin, thereby determining

their magnetic and spin properties, but the spin is regenerated up to the whole value while fermions passing through boson form. The vortex field, twisting into a spiral, is able to form subsequent structures (current tubes).

The possibility of reciprocal transformations of fermions and bosons forms does not mean that a micro-particle can stay simultaneously in two states, but it shows that a mass (an energy) can have two states and *pass from one form to another*.

It is easy to note that this model of micro-particles gives an overall original interpretation of the employed notions: *mass defect* and *supersymmetry*. At the same time, our model does not require us to introduce additional particles (super-players) which have remained undetected until now by experiments and, evidently, will not be discovered.

4 The determination of the relation of the masses proton/electron

In order to compare masses of fermions, it is necessary to consider them as objects possessing inner structure. Let us introduce the analog where the vortex tube is similar to a jet crossing the surface of liquid inside a bounded region and originating ring waves, or contours of the second order (which originate, in turn, contours of the third order, etc.). Let this region of intersection correspond to a micro-particle. Then it is considered now as a proper contour and can be characterized by parameters of the contour: a quantum number n , the radius of the vortex thread r , the circuit velocity v and the mass of the contour M .

Let us proceed to determine the quantum numbers for micro-particles. We express the typical spin of fermions through parameters of their characteristic contour, being restricted to self-evident cases, namely:

1) the spin of the particle equals the momentum of the contour as a whole:

$$\frac{h}{4\pi} = Mvr, \tag{6}$$

2) the spin of the particle equals the momentum of the contour, related to the unity element of the contour structure (the photon):

$$\frac{h}{4\pi} = \frac{Mvr}{z}, \tag{7}$$

where $h = 2\pi am_e cr_e$ is the Planck constant.

The parameters of M , v , r following from the charge conservation condition are determined as [3]:

$$M = (an)^2 m_e, \tag{8}$$

$$v = c_0^{1/3} \frac{c}{(an)^2}, \tag{9}$$

$$r = c_0^{2/3} \frac{r_e}{(an)^4}, \tag{10}$$

and the number of photons z in the contour for the case of the decay of the contour (ionization) is

$$z \approx n^4. \tag{11}$$

The following evident relation ensues from the expression of the linear density ε_0 (1):

$$\frac{l_y}{r_e} = \frac{m_y}{m_e} = \frac{M}{m_e} = (an)^2. \tag{12}$$

In other words, the relative length of the current tube expressed through the units r_e equals the boson mass M expressed through the units m_e .

Using the parameters obtained in (8), (9), (10), (11) from (6) and (7), we find:

1) for the first particle, assuming that it is a proton

$$n = n_p = \left(\frac{2c_0}{a^5}\right)^{1/4} = 0.3338, \tag{13}$$

2) for the second particle, assuming that it is an electron

$$n = n_e = \left(\frac{2c_0}{a^5}\right)^{1/8} = 0.5777. \tag{14}$$

Taking into account properties of fermions and bosons in our model, we conjecture that the boson thread is able to pack extremely compactly into the *fermion form* by a process of oscillation along the Y -axis. This packing is possible along all four coordinates (degrees of freedom), because this structure can form subsequent structures. Using (10) and (12), we find that the relative linear dimension of a fermion along the X -axis is proportional to the radius of the vortex thread. It can be expressed by the formula:

$$\frac{r}{r_e} = \left(\frac{r}{r_e}\right) \left(\frac{l_y}{r_e}\right)^{1/4} = \frac{(c_0)^{2/3}}{(an)^{7/2}}. \tag{15}$$

For instance, substituting into the above-obtained formulas $n = n_p$, we find the characteristic dimensions of the proton structure expressed through the units r_e : the radius of the vortex thread $r = 0.103$, the linear dimension along the X -axis $r_x = 0.692$ and the length of the vortex thread $l_y = 2092$. For the electron, by the substitution $n = n_e$, we have, respectively: 0.0114, 0.1014 and 6266.

Of course, the expression (15) has only qualitative character, but it can be used for the calculation of the *mass relation* of arbitrary fermions, assuming that the respective masses are proportional to their four-dimensional volumes:

$$\frac{m_{xp}}{m_{xe}} = \left(\frac{r_{xp}}{r_{xe}}\right)^4 = \left(\frac{n_e}{n_p}\right)^{14}. \tag{16}$$

For the given couple of particles, we have the relation $\left(\frac{0.5777}{0.3338}\right)^{14} = 2160$, therefore it is evident that this couple is

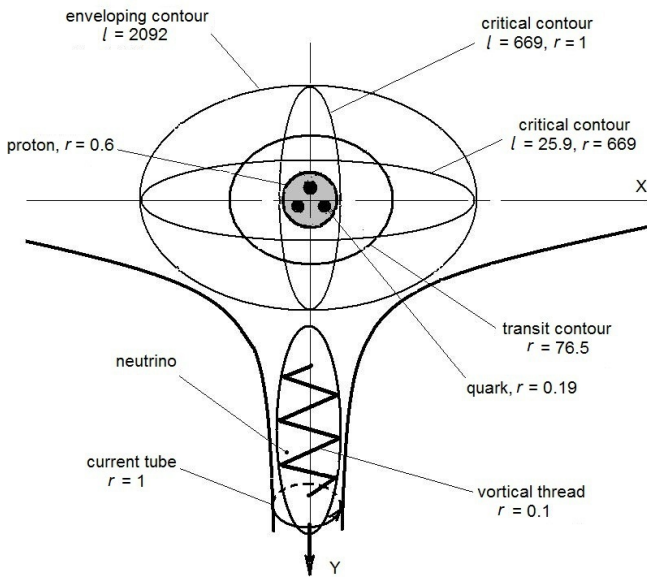

Fig. 1: The contours: scheme of the contours of the proton, and their sizes (in the units of r_e).

really *proton* and *electron*. Thus the given relation is equal to the mass of the proton expressed by the units of the electron mass. It is more evident, because the boson mass of a particle m_{yp} is almost equal to the fermion mass m_{xp} , and it is non-randomly so. Let these masses be equal, then the more precise value is the boson mass according to (12), because it does not depend on the photon number z , which is determined by means of the approximated formula. Then we can correct also the value n_e using the relation (16), and accept that its value is equal to 0.5763. It is necessary to correct the proton mass and electron charge by the cosine of the Weinberg angle. We obtain, as the final result, an almost exact value of the observed proton mass:

$$\frac{m_p}{m_e} = (an_p)^2 \cos q_w = 1835. \quad (17)$$

The Weinberg angle has also a geometric interpretation as $\cos q_w = \left(\frac{1}{2\pi}\right)^{1/14}$, which confirms indirectly the correctness of the expression (16) also.

The masses of other particles expressed through the units of the electron mass are calculated: for the fermion — according to (16), assuming that n_p is the quantum number for an arbitrary fermion, and for the boson — according to (12).

The quantum numbers for the electron n_e and the proton n_p are their inner determinant parameters, emerging into the influence zone of these particles. The parameter n_e determines the length of the enveloping contour of the electron as a circle of the length $l_y = (an_e)^2 r_e$, corresponding to three inscribed circles of the diameter d_y . The vortex threads rotate inside these circles. This diameter equals the Compton wavelength, i.e. the amplitude of electron oscillations, which

follows from the Dirac equation (the phenomena “*Zitterbewegung*”). Evidently, it follows from geometric reasons:

$$d_y = \frac{(an_e)^2 r_e \sin(60^\circ)}{2\pi} = 2.423 \times 10^{-12} \text{m}, \quad (18)$$

which coincides with the Compton wavelength, where “*Zitterbewegung*” is confirmed by experiments [6].

Analogously, the parameter n_p determines the length of the contour of the proton of the diameter $d_y = \frac{(an_p)^2 r_e}{\pi}$ enveloping the extremely contracted $p^+ - e^-$ -contour, parameters of which reach critical values with $v = c$, Fig. 1. It follows in this case from (9):

$$n_p = n_{min} = \frac{c_0^{1/6}}{a} = 0.1889 \quad (19)$$

and using (12) we find further $l_y = c_0^{1/3} r_e = 669 r_e \approx d_y$.

The excitation of elementary particles gives a set of their non-stable forms. So, fermions can have more porous and voluminous packing of boson threads, forming hyperons, etc. Apparently, some preferred configurations of packing exist, but the most compact is a proton, for which the volume and the mass of the particle are *minimal* for baryons.

5 Three generations of elementary particles

A micro-particle is considered in our model as an actual contour, therefore any contour connecting charged particles can be compared with a particle included in a greater contour; i.e. the mass of a relatively lesser contour is assumed to be the mass of a hypothetical fermion (e.g. a baryon as the analog of a proton for greater one), as shown in Fig. 2. Thus, there can exist correlated contours of the first and following orders forming several generation of elementary particles. It is clear that two quantum numbers correspond to every particle depending on its classification: 1) the particle is considered as a fermion (the analog of the proton being part of the greater contour of the following class); 2) the particle is considered as a boson (the mass of the contour of the previous class of particles). Fermion and boson masses are equal only for a proton, besides they have the same quantum number $n = 0.3338$.

The analog of a proton for the μ -contour is the mass of the standard contour $M = c_0^{2/3} m_e$. We find from (16) its quantum number $n_\mu = 0.228$. The analog of a proton for the τ -contour is the mass of the μ -contour, and n_τ is determined from extreme conditions, i.e. when $v \rightarrow 1$, $r \rightarrow 1$ and $n_\tau = n_{min} = 0.1889$. Then we find from (16) the mass of the μ -contour or the τ -analog of a proton which equals $6.05 \times 10^6 m_e$.

It is logical to assume that by analogy with the second class that this mass also consists of three bosons (the middle mass of every boson $2.02 \times 10^6 m_e$, i.e. 1030 GeV), which corresponds to the upper bound of the mass of the unknown Higgs boson. Thus, in reality, the τ -contour is the largest and the last one in the row.

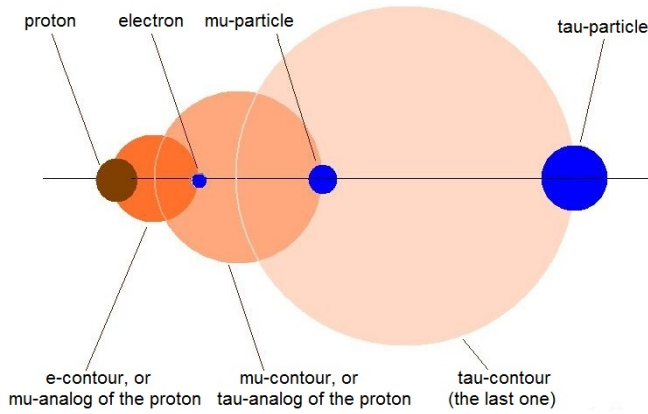

Fig. 2: Scheme of the families of the elementary particles.

Assume that the relation between the masses of baryons and their leptons in the following classes of particles, i.e. between masses of the μ -analog of the proton and a muon, and the τ -analog of a proton and a taon, is the same as for a proton-electron contour: it equals 2092. Then, using the obtained value, we can estimate the masses of other leptons. The mass of a *muon* equals $\frac{4.48 \times 10^5}{2092} = 214 m_e$, whereas the mass of a *taon* equals $\frac{6.05 \times 10^6}{2092} = 2892 m_e$.

The μ - and the τ -analogs of protons as baryons do not actually exist, but their boson masses $(an_\mu)^2 m_e$ and $(an_\tau)^2 m_e$ are close to the masses of lightest mesons — kaon and a couple of pions.

6 On the proton's structure

Continuing a hydrodynamic analogy, we assume that any charged particle included in a contour of circulation is the region where a flow of the medium intersects the boundary between X - and Y -regions: the phase transformation is realized in this boundary and the parameters attain *critical values*.

Let us now introduce the notion the density of a fermion and a boson mass: $\rho_x = \frac{m_x}{w_x}$ and $\rho_y = \frac{m_y}{w_y}$. Neglecting their exact forms, assume three-dimensional volumes of fermions and bosons in the simplest form: a fermion — as a sphere $w_x = r_x^3$, a boson thread — as a cylinder $w_y = r^2 l_y$.

Using (10), (12), (15), (16), we obtain, after transformations, their respective densities:

$$\rho_x = \frac{\rho_e n_e^{14} a^{10.5}}{n^{3.5} c_0^2}, \quad (20)$$

$$\rho_y = \frac{\rho_e (an)^8}{c_0^{4/3}}, \quad (21)$$

where ρ_e is the density of the electron for a classical volume $\frac{m_e}{r_e^3} = 4.071 \times 10^{13} \text{ kg/m}^3$.

Of course, the densities of fermion and boson masses by the critical section are equal. Then we find by $\rho_x = \rho_y$ the critical quantum number and the density:

$$n_k = \frac{n_e^{1.217} a^{0.217}}{c_0^{0.058}} = 0.480, \quad (22)$$

$$\rho_k = \frac{\rho_0 (an_e)^{9.74}}{c_0^{1.797}} = 7.65 \times 10^{16} \text{ kg/m}^3, \quad (23)$$

It is possible to ascribe these averaged parameters to some particle — a *quark*, existing only inside the phase transfer region. At once note that a quark by this interpretation is not a specific particle but only a part of the mass of a proton, obtaining critical parameters. The value of the mass can be determined from the formula (16): $m_k = 12.9 m_e$. It is easy to calculate further other parameters of an electronic quark. It is possible to verify that the density of a quark is between the fermion and boson densities of a proton, and its size goes in to the size of a nucleon.

The critical velocity of a vortex current is determined from the known hydrodynamic equation:

$$v_k = \left(\frac{p_k}{\rho_k} \right)^{1/2}, \quad (24)$$

where in this case: v_k is the critical velocity, $\rho_k = \frac{m_k}{w_k}$ is the critical density, w_k is the volume of the quark, p_k is the pressure in the critical section, or the energy related to a corresponding volume. The energy of the standard contour equals $m_e c^2$ [3], and the critical volume is determined as $z_k w_k$, where z_k is the number of quarks.

Substituting the indicated values and expressing also v_k through (9), we find from (24) the number of quarks as

$$z_k = \frac{(an_k)^4 m_e}{c_0^{2/3} m_k} = 3.2. \quad (25)$$

This result shows that the flow of the general contour must split into *three parts* in the region of the proton so as to satisfy the conditions of critical density and velocity. The relation of boson masses of an electron and a proton equals the same value. In fact, using (12), we obtain $\frac{M_e}{M_p} = \left(\frac{n_e}{n_p} \right)^2 = 3.0$.

It means that in order that the conditions of current continuity and charge steadiness in any section of the contour are realized, *inverse circulation currents* must arise in a neighborhood of a proton. It can be interpreted as a whole that zones with different signs of charge exist in a proton. Using a *minimal number of non-recurrent force current lines*, we can express schematically current lines in a proton in a unique way, as shown in the Fig. 3

As seen, there exist two critical sections with a conditionally plus current (up in the scheme) and one section with a conditionally minus current (down in the scheme), where three current lines correspond to a general current in the scheme. Therefore, the fermion surface of a proton is constructed: the regions where force lines intersect the critical sections on the line 0 – 0 inside a proton will be projected

on this surface in the form $+2/3, +2/3, -1/3$ from the total charge according to the number and direction of the force lines intersecting this surface.

Therefore, it is more correct to associate quarks not with critical sections but with *steady ring currents*, containing one or two closed single contours intersecting the critical section, as follows from the scheme. Therefore the masses of quarks can be determined as $1/3$ or $2/3$ from the summary-calculated $12.9 m_e$, i.e. they must be equal, respectively, to $4.3 m_e$ and $8.6 m_e$, which coincides in fact with the masses of light quarks determined at the present time.

Parameters of quarks of μ - and τ -classes are calculated analogously by substitution of muon and taon quantum numbers in place of n_e , respectively, (Table 1).

Of course, the proposed structure of the proton is a hypothesis of the author only. Nevertheless, the definite numbers and masses of quarks here do not contradict the ones obtained by other methods earlier. Concerning the *confinement* or non-flying of quarks: this phenomenon is self-evident, because a proton in the presently given model has no combined parts, but it has only local features in its structure. The density of a proton in critical-value regions is considerable less than its fermion density: they are, probably “holes” and, of course, they cannot be distinguished as individual particles. On the other hand, only regions of critical sections, being of advanced frontal velocity pressure (dynamical pressure), are observed by experiments as *partons*.

We can deduce one more reason on behalf of the stated model: the Georgi-Glashow hypothesis of a linear potential exists. According to this hypothesis, between infinitely heavy quarks there must act, independently from a distance, a force of attraction (approximately 14 tons). Current tubes are just linear objects in our model.

Concerning the force: its limiting value can be expressed here as the sum of electrical forces’ projections relative to the center of the right triangle. The forces act in pairs between critical sections carrying an elementary charge by the condition that the distance between them is minimal (according to (10), for a quark $r = 0.0239 r_e$). Then, taking into account (3), we find $F_e = \frac{3 \cos 30^\circ}{\mu_0 r^2} = 1.33 \times 10^5 \text{ N}$ or 13.3 tons.

7 The weak interaction and the neutrino

The stated scheme of a proton allows us to give a native illustration to the proton-neutron transitions in the weak interactions. For example, in the case of the so-called hunting phenomenon (*e-capture*) if a proton and an electron bring together up to $n \leq 1$ an intermediate contour is formed, connecting the particles temporarily. The boson mass of the contour, in addition, must be more than the sum of the combined boson masses of the proton and the electron, precisely:

$$M = (an)^2 m_e + m_{yp} + m_{ye}. \quad (26)$$

Let $n = 1$, then $M = 27108 m_e$. Using the general relation

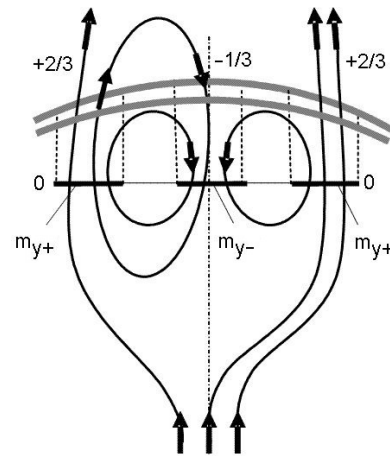

Fig. 3: Scheme of the proton: distribution of the current lines inside the proton.

between the boson mass of a contour and a lepton, we find the mass of the fermion for this contour: $m_x = \frac{27137}{2092} = 12.9 m_e$.

This result turns out to be independent. The obtained value M coincides with a total mass of the quark and confirms that in the process of *e-capture* the temporal contour is actually formed, which is analogous to earlier considered contours (section 5) where one of the critical sections of a proton as a lepton is present.

Recall that our model contour has the properties of ideal liquid, therefore closed ring formations as parts of this continuum are absolutely inelastic and absolutely deforming at the same time. The contour connecting the particles, by their further coming together, transmits a share of energy-momentum to the inner structure of the proton, deforms and orients itself to the *Y*-region; then it is extracted as a *neutrino* which takes the momentum (spin) of the electron (Fig. 1). In other words, this process is similar to a separation of charge and spin — the phenomenon, fixed in hyperfine conductors [7], which vortex tubes are supposedly similar to.

A similar contour is formed by every act of the weak interaction, and it corresponds to the exchange of intermediate bosons. The relative slowness of this process is connected with the *time constant* t . The typical value of t , taking into account a spiral derived structure, determined by the time during which a circulating current passes with the velocity v through all line of the “stretched” counter (the size of *W*-, *Z*-particles). For the standard contour we have

$$t = (4.884)^2 \frac{R_b(r_e/r)}{v} = 1.25 \times 10^{-9} \text{ sec}, \quad (27)$$

where 4.884 is the quantum number for a standard contour [3], r and v are determined by (9) and (10) by the given n , R_b is the Bohr first radius.

It follows from the logic of the model, that a neutrino is a particle analogous to a photon, but it spreads in the *Y*-region,

i.e. it transfers energy along the vortex tube of the contour. As known, two kinds of these particles: a neutrino — with a left spiral and an anti-neutrino — with a right spiral, corresponding to two poles of a general contour. Because a neutrino is a closed structure and exists only in the Y -region, it has no considerable charge and the mass in a fermion form (i.e. in form of the X -surface objects). Probably, a neutrino has a spiral-toroidal structure and thus it inherits or reproduces (depending on the type of the weak interaction) the structure of the vortex tube of the contour.

8 On the magnetic-gravitational interaction

Consider a possibility of existence of the mentioned closed contours at the express of an equilibrium between magnetic forces of repulsion and electrical forces of attraction. Let us formally write this equality for tubes with oppositely directed currents, neglecting the form of the contour and its possible completeness, and expressing the magnetic forces through the Ampere formula in the “Coulomb-less” form:

$$\frac{z_{g1}z_{g2}\gamma m_e^2}{r_i^2} = \frac{z_{e1}z_{e2}\mu_0 m_e^2 c^2 l_i}{2\pi r_i \times [\text{sec}^2]}, \quad (28)$$

where z_{g1} , z_{g2} , z_{e1} , z_{e2} , r_i , l_i are gravitational masses and charges expressed through masses and theirs length.

Substituting μ_0 from (2), we derive from (28) the characteristic size of the contour as the *mean-geometric* of two linear values:

$$l_k = \sqrt{l_i r_i} = \sqrt{\frac{z_{g1}z_{g2}}{z_{e1}z_{e2}}} \sqrt{2\pi\gamma\epsilon_0} \times [\text{sec}]. \quad (29)$$

The parameter l_k is composite. Using the formulas (10), (12), (29), we obtain for a contour with a unit charge the values l_i and r_i , where the lengths are expressed by the units of r_e :

$$l_i = \frac{c_0^{2/3}}{l_k^2}, \quad (30)$$

$$r_i = \frac{l_k^4}{c_0^{2/3}}. \quad (31)$$

The contour can be placed both in the X -region (for example, a contour $p^+ - e^-$) and in the Y -region (inside an atomic nucleus). A deformation of the contour, for example, its contraction by the e -capture, takes place by means of the β -decay energy. When a proton and an electron come together, energy and fermion-mass increase of the contour occurs, while the boson mass decreases, but the impulse (charge) is conserved.

Consider some characteristic cases of a contour contraction and of a further transition of the nucleon from a proton form into a neutron one.

a) Write the equality (29) for $p^+ - e^-$ -contour, where $z_{g1} = \frac{m_p}{m_e \cos q_w}$ is the relative mass of the proton, where the

cosine of the Weinberg angle is considered, and $z_{g2} = 1$. In this case $l_k = 5977.4 r_e$, which corresponds to the value $\frac{R_b}{\pi}$ exactly. In other words, for the contour $p^+ - e^-$:

$$l_k = \sqrt{\frac{m_p}{m_e \cos q_w}} \sqrt{2\pi\gamma\epsilon_0} \times [\text{sec}] = \frac{R_b}{\pi}. \quad (32)$$

The extension of the contour is now impossible, because all the mass of the proton is involved in the contour of circulation. Thus the parameters l_i and r_i are limited and equal to 0.0125 and $2.850 \times 10^9 r_e$, respectively, i.e. the length of contour tubes equals the radius of the vortex thread of an electron, approximately (section 4), and the distance between them equals the limiting size of the hydrogen atom ($390^2 R_b$). The last result is confirmed by the fact that the maximal level of energizing of hydrogen atoms in the cosmos, registered at the present time by means of radio astronomy, does not exceed $n = 301$ [8].

b) Let l_k be equal to the Compton wavelength $\lambda_k = 2\pi a r_e$. In this case, l_i and r_i are equal to 0.604 and $1.227 \times 10^6 r_e$, respectively, i.e. the length of contour tubes corresponds to the diameter of a nucleon, and the distance between them — to the size of the most atomic size ($8^2 R_b$). Thus, taking into account (30) and the expression for λ_k , we can express the proton radius in the form:

$$r_p = \frac{c_0^{2/3}}{8\pi^2 a^2} = 0.302 r_e = 851 \text{ fm}, \quad (33)$$

which corresponds to the size of the proton, determined by the last experiments (842 fm) [9].

The equality (29) of $l_k = \lambda_k$ is observed, if the relation $\frac{z_{g1}z_{g2}}{z_{e1}z_{e2}} = 43.4$. This value can be interpreted as the product of the masses of two quarks $z_{g1}z_{g2}$, included in the contour of a nucleon or an atomic nucleus.

c) The critical contour of $v = c$. Here $l_i = c_0^{1/6}$, $r_i = c_0^{1/3}$, $l_k = c_0^{1/4}$ by the units of r_e . The equality (29) is fulfilled provided that the relation $\frac{z_{g1}z_{g2}}{z_{e1}z_{e2}} \approx 1$. A fraction of the impulse is transmitted to its own current (quark) contour of the proton by a further contraction of the contour, because the velocity of circulation cannot exceed the light velocity.

d) The contour is axially symmetric and is placed at the intersection of regions X and Y , which corresponds to a transient state between a proton and a neutron. It is logical to assume that the mass of the contour is situated in a critical state which is intermediate between fermion and boson forms. It is possible to suppose, according to the considered model, that a boson thread is contracted already into a contour by the length l_k , but it is not packed yet into a fermion form.

In this case $l_i = r_i = l_k = c_0^{2/9} r_e$, and the equality (29) is fulfilled provided that the relation $\frac{z_{g1}z_{g2}}{z_{e1}z_{e2}} \approx 1/3$. The limit impulse of this contour $I = \pi\epsilon_0 l_k c \approx \frac{e_0}{3 \cos q_w}$, consequently it could correspond to one excited quark contour.

The size of the magnetic-gravitational contour is correlated with the size of an atom depending on the value of gravi-

tational masses involved in its structure; the product of these masses is in the limits $(5.4 \dots 43)m_e^2$ in the intervals of the main quantum numbers $n = 1, \dots, 8$. Moreover, in the region X the relation $\frac{z_{g1}z_{g2}}{z_{e1}z_{e2}}$ is proportional to the degree of deformation of the contour, i.e. to the relation of the size of the symmetric contour l_k with respect to the small axis of the deforming one; the coefficient of proportionality is *constant* and equal to $0.34 \approx 1/3$.

The contour is reoriented into the region Y by the proton-neutron transition. However in this case, in the region Y , there is a *sole solution*, which determines the critical contour by $v = c$. Here $l_i = c_0^{1/3}$, $r_i = 1$, $l_k = c_0^{1/6}$ by the units r_e . The contour is inserted in the current tube with the size r_e and the inverse relation is realized exactly for this contour:

$$\frac{z_{e1}z_{e2}}{z_{g1}z_{g2}} = \frac{l_k}{3r_i}. \quad (34)$$

Taking into account that for the symmetric contour $l_k = c_0^{2/9}r_e$ and using the formula (29), we have, after transformations,

$$\frac{c_0^{5/9}r_e^2}{2\pi\gamma\varepsilon_0 \times [\text{sec}^2]} = 3. \quad (35)$$

The uniqueness of the solution indicates that, by the transition of a proton into a neutron, the contour is isolated into the region Y , namely with the corresponding critical parameters, and corresponds to a neutrino.

The expressions (32) and (35) are exact, as the values π and 3 reflect the geometry of the space and its three-dimensionality. It is possible to deduce from them the formula of the *gravitational constant* using the least quantity of values possessing dimensions, and to obtain also the more exact expression for the Weinberg angle. So, removing the expression for ε_0 , we find from (35), after transformations,

$$\gamma = \frac{c_0^{5/9}}{6\pi\rho_e \times [\text{sec}^2]} = 6.6733 \times 10^{-11} \text{ m}^3/\text{sec}^2 \text{ kg}, \quad (36)$$

from (32) and (35):

$$\cos q_w = \frac{\pi^2 c_0^{5/9} m_p}{3a^4 m_e} = 0.8772. \quad (37)$$

Note that the expression for γ shows that the gravitational constant is an acceleration, i.e. the velocity at which the specific volume of matter in the Universe changes, in view of its expansion.

Thus, the analysis of a magnetic-gravitational equilibrium, additionally and independently, confirms the existence of three zones in the proton structure and the correspondence to the masses of light quarks of the active parts of the proton mass, included in the circulation. The conditions stated in sections 4, 6, 8 reflect different aspects of the unit structure of a proton as a whole.

9 The determination of the mass and lifetime of the neutron

A neutron is somewhat heavier than a proton, which is due to the excited condition of its own current (quark) contours. But in SM, only one quark from among the three undergoes a transformation by the proton-neutron jump. Let us assume that this quark contour obtains in addition the energy of a symmetric contour (which is considered in this situation as the own contour of a particle of the mass $\varepsilon_0 l_k$), which leads to its size extension and, respectively, to the increase of the nucleon mass.

Let us equate a total-energy differential, obtained by a nucleon, to the rotational energy of a symmetric contour except the initial rotational energy of a quark contour:

$$\frac{(m_n - m_p)c^2}{\cos q_w} = \varepsilon_0 l_k v_i^2 - \frac{m_k v_k^2}{2}, \quad (38)$$

where v_i is the peripheral velocity of a symmetric contour, v_k is the peripheral velocity of a quark contour, $\frac{1}{2}m_k$ is the averaged mass of a quark contour (section 6). Starting from the masses $c_0^{2/9}m_e$ and $12.9m_e$, their quantum numbers are determined from the formula (16), the rotational velocities — from (9). Substituting these values we obtain after transformations the expression (by the unites of m_e and r_e):

$$m_n - m_p = r_{ie} \left(c_0^{2/7} - \frac{m_k^{9/7}}{2} \right) \cos q_w = 2.53m_e, \quad (39)$$

where r_{ie} is the radius of the vortical thread of the electron determined from (10).

After discharge of a neutrino and deletion of three enclosed current lines, there remains one summary contour in the neutron. This contour consists of three closed force lines. Its size can maximally reach the size of a symmetric contour by means of the obtained energy. This contour forms three vortex threads by the length l_y with co-directed currents. These threads rotate relative to the longitudinal axis and have the boson masses m_y . The equality of magnetic and inertial (centrifugal) forces for vortex threads must follow from the equilibrium condition. By analogy with (28), we have:

$$\frac{m_y v_0^2}{r_i} = \frac{z_{e1}z_{e2} \mu_0 m_e^2 c^2 l_y}{2\pi r_i \times [\text{sec}^2]}, \quad (40)$$

where v_0 is the *peripheral velocity* of vortex threads. Taking into account (1), (2), (12), we find from (40):

$$v_0 = \frac{\sqrt{z_{e1}z_{e2}} r_e}{\sqrt{2\pi} \times [\text{sec}]}, \quad (41)$$

where the velocity does not depend on the length of the vortex threads and the distance between them.

A spontaneous, without action of outer forces, neutron-decay is realized just owing to the own rotation of vortex

threads, causing a variation of its inner structure. In other words, the excited contour deforms and is turned into another configuration with less energy, which corresponds to the initial energy of the proton. This process must characterize itself by the *constant of time* which can be determined as a quotient from a division of the characteristic linear size in terms of the peripheral velocity v_0 . As the diameter of the tube is not determined, r_i is not determined, then it is expediently to consider the length of a symmetric transient contour πl_k as a characteristic size. In this case, the constant of time takes the form for unit charges:

$$\tau = \frac{\pi l_k}{v_0} = \sqrt{2\pi^3} c_0^{2/9} \times [\text{sec}] = 603 \text{ sec.} \quad (42)$$

On the other hand, the constant of time can be determined also from energetic reasons, taking into account the difference of the masses of nucleons.

Let a neutron lose step-by-step the transmitted total energy $(m_n - m_p)c^2$ by portions which are proportional to the energy of an electron $m_e v_e^2$, where v_e is the electron's own-contour rotational velocity during the time equal to the period of vortex threads rotation inside the current tube. Determine this characteristic time as $\frac{r_e}{v_0} = 2.51 \text{ sec}$, then, taking into account (9), (39), (41), we obtain the period of the total dispersion of the energy by a neutron:

$$\tau = \frac{\sqrt{2\pi}(m_n - m_p) \times [\text{sec}]}{r_{ie} \cos q_w} = 628 \text{ sec,} \quad (43)$$

The obtained constants of time correspond to the half-life of a neutron $\tau_{1/2}$. By definition, $\tau_{1/2} = \ln 2 \times \tau_n$, where τ_n is the lifetime of a neutron; its value which is obtained by one of the recent studies is 878.5 sec [10], then $\tau_{1/2} = 609 \text{ sec}$.

Note that the contour of a neutrino also consists of three different vortex fields and probably undergoes periodically small variations of time when forming three configurations relative to a chosen direction. This result, probably, can explain the problem of solar neutrinos and their possible variations.

10 On the β -decay energy

The energy of the excited contour of a neutron by its decay is transmitted to an electron and an anti-neutrino extracted by this process. Taking into account (1), (9), (16), we can express, in relative units, the additional impulse $I_\beta = \pi \varepsilon_0 l_k v_i$ transmitted to a nucleon from the symmetric contour:

$$I_\beta = \frac{\pi c_0^{37/63}}{(a n_e)^2} = 47.92 m_e c. \quad (44)$$

This impulse is distributed between the contours of a neutrino and an electron with the total mass M_β , and these contours are present in any process of the weak interaction.

In addition, the mass of a neutrino contour is $c_0^{1/3} m_e$, and the mass of an electron contour also cannot be smaller than

the critical value $c_0^{1/3} m_e$. The velocity of rotation of the contour by the impulse transmission will be $\frac{I_\beta}{M_\beta}$, and the β -decay energy is $E_\beta = \frac{I_\beta^2}{M_\beta}$; then its maximal value, transmitted additionally to the electron and neutron contours, and, consequently, to the electron and the neutrino, occurs at $M_\beta = 2c_0^{1/3} m_e$. Substituting the values, we obtain the boundary value of energy: $E_{\beta 0} = 1.72$ (in the units of $m_e c^2$) or 0.88 MeV.

The same result can be obtained by means of another, independent way, if we assume that the transient contour is symmetric from an energetic viewpoint (but not from a geometric one). Assume that the limit energy of the mass of a fermion contour equals the energy of rotation of this mass in a boson form, i.e. $m_x c^2 = m_y v^2$. Introduce also into the expression of the impulse the value of the spin of the contour: it allows us to characterize the process of the β -decay more objectively. Correct to this end the quantum number n_e for the unit relative mass (the mass of an electron) in the case of arbitrary spin. It is evident that, taking into account of (7) and (14), $n_{ei} = \frac{n_e}{k^{1/8}}$, where k is the relation between an arbitrary spin value and the spin 1/2.

Taking into account the aforesaid equalities and using the formulas (9), (12), (16), we obtain as a result the expression for the impulse of the contour which is analogous to (44), in the units of $m_e c$:

$$I_\beta = \frac{k^{7/12} c_0^{11/9}}{(a n_e)^{14/3}}. \quad (45)$$

It gives, for $k = 2$, the value of the impulse $47.96 m_e c$, coinciding with the result of the formula (44).

Thus we have showed that, by the transient condition of a nucleon, the symmetric contour obtains temporarily the spin 1 (joining the spin of an electron 1/2, which then takes a neutrino).

This energy of the β -decay for isotopes can be higher, and its maximal value can be determined. According to our model, a symmetric contour can transfer the limit impulse which equals one third of a charge (section 8, d). Then, taking into account (5), assuming $M_\beta = 2c_0^{1/3} m_e$ and introducing the Weinberg angle, we obtain as a result the simple expression of the β -decay limit energy in the units of $m_e c^2$:

$$E_{\beta \text{lim}} = \frac{c_0^{1/3} \cos q_w}{18} = 32.6 \quad (46)$$

or 16.7 MeV.

In fact, the maximal value of the β -decay energy among different isotopes is registered for the transition $\text{N}^{12} \rightarrow \text{C}^{12}$ (16.6 MeV), which coincides with the calculated value. The value of the impulse which corresponds to the given energy follows from the formula (45) by $k = 28$. In other words, the obtained spin is proportional to the number of nucleons in the nucleus (for a nitrogen, $28/2 = 14$).

In the case of e -capture only a neutrino is extracted, then $M_\beta = c_0^{1/3} m_e$, and the typical energy of the neutrino must be

1.75 MeV.

Namely, such contours, possessing symmetric forms and balanced energies (quarks), are the base of the microstructure of particles: *three* quarks for baryons and *two* — for mesons. Partially, for $k = 1$, the contour, possessing the spin 1/2, has the mass $146.4 m_e$. Consequently, two such contours, depending on their properties of combination, can form mesons more easily — pions, and their excited states — , i.e. heavier micro-particles.

Thus, the results obtained in sections 8, 9, 10 in the framework of our model correspond to well-known parameters and admissible limits. Various coincidences of the calculated values with reality (e.g. the number of quarks, the sizes of the axes of characteristic contours, the size of the proton, the gravitational constant, the difference of the masses of nucleons, the half-life of the neutron, the β -decay energy) cannot have accidental nature: they prove that the structure satisfying the magnetic-gravitational equilibrium condition really exists in the micro-world.

11 The magnetic moments of the proton and the neutron

The anomalous magnetic moment of the proton μ_p in the given model can be calculated as follows. The value μ_p depends on the boson configuration of a proton and is determined relative to the Y -axis where μ_p is the product (charge \times velocity \times path). We thus have, for a vortex thread, a peripheral velocity v and a circumference πr . Substituting v and r from (9) and (10), we obtain as a result:

$$\mu = \frac{\pi c_0 c e_0 r_e}{(a n_p)^6} = 1.393 \times 10^{-26} \text{ am}^2, \quad (47)$$

which differs insignificantly from the experimental value.

The magnetic moment of the neutron equals two thirds of the proton's magnetic moment, i.e. proportional to the reduction of the number of intersections of the critical sections by current lines for a proton (six instead of nine, existing in a proton, see Fig. 3). Naturally, the sign of the moment changes in addition, because three positive enclosed currents are removed.

The calculated values of some parameters with respect to reality, or obtained earlier by other methods, are given in Table 1.

12 Conclusion

This work is an attempt to add a physically descriptive interpretation to some phenomena of the micro-world using both topological images of Wheeler's geometrodynamics idea and further macro-world analogies. This approach allows us to include into consideration inertial and gravitational forces.

This model has a logical demonstrative character and determines a scheme for the construction of a possible theory adding up the Standard Model (SM) of particle physics. The new theory must use such mathematical apparatus, in the framework of which vortex structures and their interactions

Particles*	Calculated data	Actual data
<i>Family 1</i>		
Proton	1835	1836
Electron	1	1
Quark	12.9 (4.3; 8.6)	3.93; 9.37
<i>Family 2</i>		
μ -analog of the proton, $m_{x\mu}$	4.48×10^5	4.92×10^5 †
Muon	214	206.8
μ -quark	8780	3230; 276
<i>Family 3</i>		
τ -analog of the proton, $m_{x\tau}$	6.31×10^6	?
τ -lepton	2892	3480
τ -quark	233000	348000; 8260
<i>Other parameters</i>		
Charge of the electron, kg m/s	1.603×10^{-19}	1.602×10^{-19}
Number of the quarks (on the basis of the phase transit condition)	3.2	3
Number of the quarks (on the basis of the magnetic-gravitational equilibrium)	3	3
Interacting force among the quarks, N	1.33×10^5	1.4×10^5
Weinberg angle	28.2°	28.7°
Compton wavelength, m	2.423×10^{-12}	2.426×10^{-12}
The gravitational constant, $m^3/kg \text{ sec}^2$	6.673×10^{-11}	6.673×10^{-11}
Radius of the proton, fm	851	842
Difference between the mass of the proton and the mass of the neutron, m_e	2.53	2.53
Semi-decay of the neutron (kinematic estimation), sec	603	609
Semi-decay of the neutron (energetic estimation), sec	628	609
Ultimate high energy of the β -decay, MeV	16.7	16.6
Magnetic moment of the proton, am^2	1.39×10^{-26}	1.41×10^{-26}
Magnetic moment of the neutron, am^2	-0.92×10^{-26}	-0.97×10^{-26}

*Masses of the particles are given in the mass of the electron.

†The summary mass of the W, Z-bosons.

Table 1: The actual numerical parameters, and those calculated according to the model suggested by the author.

could be described. As often mentioned by the author, the contours will be mapped out by singular configurations of force lines of some field.

Nevertheless, the present model gives a correct interpretation even in the initial, elementary form where only laws of conservation are used. It explains some phenomena misunderstood in the framework of SM and allows us to obtain qualitative and, sometimes, quantitative results by calculation of important parameters of the micro-world.

In part, this model predicts that it is impossible by means of experiments conducted at the BAC to obtain new particles — dubbed “super-partners”: rather, it is necessary to seek new massive vector bosons in the region of energies approximating 1000 GeV.

Submitted on October 13, 2011 / Accepted on January 31, 2012

References

1. Yershov V.N. Fermions as topological objects. *Progress in Physics*, 2006, v. 1, 19–26.
2. Dewitt B.S. Quantum gravity. *Scientific American*, December 1983, v. 249, 112–129.
3. Belyakov A.V. Charge of the electron, and the constants of radiation according to J.A. Wheeler’s Geometrodynamics Model. *Progress in Physics*, 2010, v. 4, 90–94.
4. Daywitt W.C. The Relativity Principle: space and time and the Planck vacuum. *Progress in Physics*, 2010, v. 4, 34–35.
5. *New Scientist*, 1998, no. 2119, 36.
6. Gerritsma R. et al. Quantum simulation of the Dirac equation. *Nature*, 2010, v. 463, 68–71.
7. Jompol Y., Ford C.J.B., Griffiths J.P., Farrer I., Jones G.A.C., Anderson D., Ritchie D.A., Silk T.W., and Schofield A.J. Probing spin-charge separation in a Tomonaga-Luttinger liquid. *Science*, 31 July 2009, v. 325, no. 5940, 597–601.
8. Pedlar A. et al. *Mon. Not. R. Astron. Soc.*, 1978, v.182, 473.
9. Pohl R. et al. The size of the proton. *Nature*, 08 July 2010, v. 466, 213–216.
10. Serebrow A.P. The Measurement of the neutron lifetime with the use of gravitational traps of ultra-cold neutrons. *Uspekhi-Physics*, 2005, v. 175, no. 9, 905–923.

Quantum Uncertainty and Relativity

Sebastiano Tosto

Italy. Email: stosto@inwind.it

The major challenge of modern physics is to merge relativistic and quantum theories into a unique conceptual frame able to combine the basic statements of the former with the quantization, the non-locality and non-reality of the latter. A previous paper has shown that the statistical formulation of the space-time uncertainty allows to describe the quantum systems in agreement with these requirements of the quantum world. The present paper aims to extend the same theoretical model and approach also to the special and general relativity.

1 Introduction

Merging quantum mechanics and general relativity is surely the most challenging task of the modern physics. Since their early formulation these theories appeared intrinsically dissimilar, i.e. conceived for different purposes, rooted on a different conceptual background and based on a different mathematical formalism. It is necessary to clarify preliminarily what such a merging could actually mean.

A first attempt was carried out by Einstein himself in the famous EPR paper [1] aimed to bridge quantum behavior and relativistic constraints; he assumed the existence of hypothetical “hidden variables” that should overcome the asserted incompleteness of the quantum mechanics and emphasize the sought compatibility between the theories. Unfortunately this attempt was frustrated by successive experimental data excluding the existence of hidden variables. The subsequent development of both theories seemed to amplify further their initial dissimilarity; consider for instance the emergence of weird concepts like non-locality and non-reality of quantum mechanics, which make still more compelling the search of an unified view.

The most evident prerequisite of a unified model is the quantization of physical observables; being however the general relativity essentially a 4D classical theory in a curved non-Euclidean space-time, the sought model requires new hypotheses to introduce the quantization. A vast body of literature exists today on this topic; starting from these hypotheses several theories have been formulated in recent years, like the string theory [2,3] and loop quantum gravity [4], from which were further formulated the M-theory [5] and the supersymmetric theories [6]. The new way to represent the particles as vibrating strings and multi-dimensional branes is attracting but, even though consistent with the quantization, still under test. Moreover the quantization of the gravity field is not the only problem; additional features of the quantum world, the non-locality and non-reality, appear even more challenging as they make its rationale dissimilar from that of any other physical theory. The quantum mechanics postulates a set of mathematical rules based on the existence of a state vector $|\psi\rangle$ describing the quantum system in Hilbert space and a Hermitian

operator corresponding to a measure, whose outcomes are the eigenvalues that represent the observables; the evolution of a system is represented by an evolution operator $T(t)$ such that $|\psi(t)\rangle = T(t)|\psi(0)\rangle$ operating on the state vector at the initial time. To these rules overlap also the exclusion and indistinguishability principles to formulate correctly the state vectors. The relativity rests on physical intuitions about the behavior of masses in a gravity field and in accelerated systems; it postulates the equivalence between gravitational and inertial mass and aims to build a covariant model of physical laws under transformation between inertial and non-inertial reference systems.

Apart from the apparent dissimilarity of their basic assumptions, a sort of conceptual asymmetry surely characterizes the quantum and relativistic theories; on the one side abstract mathematical rules, on the other side intuitive statements on the behavior of bodies in a gravity field. If the unification of these theories concerns first of all their basic principles, the task of introducing into a unified model even the concepts of non-locality and non-reality appears seemingly insurmountable. Eventually, a further concern involves the choice of the mathematical formalism appropriate to the unified approach. In general the mathematical formulation of any theoretical model is consequence of its basic assumptions. The tensor calculus is required to introduce covariant relativistic formulae in curvilinear reference systems; is however its deterministic character really suitable to formulate a non-real and non-local theoretical model? This last remark is suggested by previous papers that have already touched on this subject.

Early results showed that a theoretical approach based on the quantum uncertainty only, introduced as a unique assumption to calculate the electron energy levels of many-electron atoms/ions and diatomic molecules [7,8], could be subsequently extended to the special relativity too [9] while being also consistent with the concepts of non-localism and non-realism of quantum mechanics. Despite this encouraging background, however, so far the implications of the concepts introduced in the quoted papers have not been fully investigated and systematically exploited. In these early papers, the connection between quantum approach and special relativity

was preliminarily acknowledged through gradual results progressively obtained, concerning however other less ambitious tasks; for instance, to assess the chance of superluminal speed of neutrinos [9]. The decisive strategy to this purpose was to regard the concept of uncertainty as a fundamental law of nature and not as a mere by-product of the commutation rules of operators. The statistical formulation of the quantum uncertainty has been proven effective on the one side to explain and account for all of the aforesaid features of the quantum world, i.e. quantization and non-reality and non-locality, and on the other side to obtain as corollaries the basic statements of special relativity too along with the invariant interval and Lorentz transformations. So it seemed sensible to exploit more profoundly these early achievements before proceeding towards a more advanced generalization including the general relativity too.

The present paper aims to collect together and push forward these preliminary results through further considerations having more general and systematic character; the approach proposed here is purposely focused towards a unifying task able to combine together quantum and relativistic requirements within the same conceptual frame. For this reason the present paper heavily rests on previous results introduced in the quoted references. While referring to the respective papers when necessary, some selected considerations very short and very important are again reported here for clarity of exposition and to make the present paper as self-contained as possible.

The paper consists of three parts. The first part, exposed in section 2, merely summarizes some concepts already published and some selected results previously achieved; these preliminary ideas are however enriched and merged together with new suggestions. The second part, section 3, stimulates further considerations approaching the intermediate target of merging together basic concepts of quantum mechanics and special relativity. The third part, section 4, aims to show that effectively even the most significant Einstein results of general relativity are compliant with the quantum approach here proposed.

The foremost concern constantly in mind is how to transfer into the beautiful self-consistency of relativity the alien concepts of quantization, non-locality and non-reality of the quantum world.

2 Preliminary considerations

The present section collects some ideas and results reported in previous papers concerning the statistical formulation of quantum uncertainty. Two equations sharing a common number of allowed states

$$\Delta x \Delta p_x = n\hbar = \Delta \epsilon \Delta t \quad (2,1)$$

are the only basic assumption of the present model. No hypothesis is made about size and analytical form of these ran-

ges, which are by definition arbitrary. These equations disregard the local values of the dynamical variables, considered indeed random, unknown and unpredictable within their uncertainty ranges and thus of no physical interest. The concept of uncertainty requires the particle delocalized everywhere in its space range Δx without any further detail about its actual motion; in practice the theoretical approach describes a system of quantum particles through their uncertainty ranges only exploiting the following positions

$$p_x \rightarrow \Delta p_x, \quad x \rightarrow \Delta x, \quad t \rightarrow \Delta t, \quad \epsilon \rightarrow \Delta \epsilon. \quad (2,2)$$

The first relevant consequence is that the calculations based on these ranges only waive in fact a specific kind of reference system. Consider for instance $\Delta x = x - x_o$: the lower boundary x_o describes the position of Δx with respect to the origin O of an arbitrary reference system R , the upper boundary x its size. So, owing to the lack of hypotheses or constraints on x_o and x , the considerations inferred through the ranges (2,2) hold in any R whatever it might be, Cartesian or curvilinear or else; also, being both boundary coordinates x_o and x arbitrary and unknowable, their role as concerns size and location of Δx in R could be identically exchanged. Hold also for the other ranges, e.g. for t_o and t of $\Delta t = t - t_o$, the same considerations introduced for x_o and x , in particular the arbitrariness of the time coordinates in the reference system where is defined the time length Δt .

If in R both boundaries are functions of time, as it is to be reasonably expected according to eqs. (2,1), then not only the range size is itself a function of time dependent on the relative signs and values of \dot{x} and \dot{x}_o , but also the results hold for reference systems in reciprocal motion; indeed a reference system R_o solidal with x_o moves in R at rate \dot{x}_o and possible acceleration \ddot{x}_o . Nothing indeed compels to regard \dot{x}_o as a constant, i.e. R_o could be non-inertial or inertial depending on whether the concerned physical system admits or not accelerations. As any outcome inferred through the positions (2,2) holds by definition in an arbitrary reference system R or R_o , it is clear since now the importance of this conclusion in relativity, which postulates covariant general laws of nature. Introducing local coordinates requires searching a covariant form for the physical laws thereafter inferred; once introducing arbitrary uncertainty ranges that systematically replace the local coordinates "a priori", i.e. conceptually and not as a sort of approximation, hold instead different considerations.

This topic will be concerned in the next subsection 4.1. Here we emphasize some consequences of the positions (2,2): (i) to waive a particular reference system, (ii) to fulfill the Heisenberg principle, (iii) to introduce the quantization through the arbitrary number n of allowed states, (iv) to overcome the determinism of classical physics, (v) to fulfill the requirements of non-locality and non-reality [9]. Hence appears sensible to think that an approach based uniquely on eqs. (2,1) through the quantum positions (2,2) is in principle suitable to

fulfil the requirements of special and general relativity too, far beyond the conceptual horizon of the quantum problems to which the quoted papers were early addressed. While being well known that the concept of uncertainty is a corollary of the operator formalism of wave mechanics, the reverse path is also possible: the operators of wave mechanics can be inferred from eqs. (2,1) [9]. The operator formalism is obtained introducing the probability $\Pi_x = \delta x / \Delta x$ for a free particle to be found in any sub-range δx included in the whole Δx during a given time range δt ; it is only required that the sub-range be subjected to the same conditions of arbitrariness and uncertainty of Δx . Analogous considerations hold in defining the probability $\Pi_t = \delta t / \Delta t$ for the particle to be confined during a time sub-range δt within a given δx , while Δt is the time range for the particle to be within Δx . These probabilities allow to infer the operators

$$p_x \rightarrow \pm \frac{\hbar}{i} \frac{\partial}{\partial x}, \quad \epsilon \rightarrow \pm \frac{\hbar}{i} \frac{\partial}{\partial t}. \quad (2,3)$$

As intuitively expected, the space and time sub-ranges δx and δt describe a wave packet having finite length and momentum that propagates through Δx during Δt . The positions (2,2), directly related to eqs. (2,1), and the non-relativistic positions (2,3), inferred from eqs. (2,1), compare the two possible ways of introducing the quantum formalism. This result is important for two reasons: (i) it justifies why eqs. (2,1) lead to correct quantum results through the positions (2,2); (ii) the connection and consistency of the positions (2,2) with the familiar wave formalism (2,3) justifies the starting point of the present model, eqs. (2,1) only, as an admissible option rather than as an unfamiliar basic assumption to be accepted itself. Although both eqs. (2,1) and the wave equations introduce the delocalization of a particle in a given region of space, in fact the degree of physical information inherent the respective approaches is basically different: despite their conceptual link, eqs. (2,1) entail a degree of information lower than that of the wave formalism; hence they have expectedly a greater generality.

Consider a free particle. Eqs. (2,1) discard any information about the particle and in fact concern the delocalization ranges of its conjugate dynamical variables only; accordingly they merely acknowledge its spreading throughout the size of Δx during the time uncertainty range Δt . Being also this latter arbitrary, the information provided by eqs. (2,1) concerns the number of states n allowed to the particle and its average velocity component $v_x = \Delta x / \Delta t$ only. The wave mechanics concerns and describes instead explicitly the particle, which is regarded as a wave packet travelling throughout Δx ; as it is known, this leads to the concept of probability density for the particle to be localized somewhere within Δx at any time. The probabilistic point of view of the wave mechanics, consequence of Π_x and Π_t , is replaced in eqs. (2,1) by the more agnostic total lack of information about local position and motion of the particle; this minimum information, con-

sistent with the number of allowed states only, corresponds in fact to the maximum generality possible in describing the physical properties of the particle. The fact that according to eqs. (2,1) the particle could likewise be anywhere in all available delocalization range, agrees with the Aharonov-Bohm effect: the particle is anyhow affected by the electromagnetic field even in a region of zero field, because the probabilistic concept of “here and then there” is replaced by that of “anywhere” once regarding the region of the concerned field as a whole 3D uncertainty volume whose single sub-regions cannot be discerned separately. These conclusions also explain the so called “EPR paradox”: the idea of spooky action at a distance is replaced by that of action at a spooky distance [9], because the positions (2,2) exclude the concept of local positions and thus that of a specific distance physically distinguishable from any other distance. Just because ignoring wholly and in principle the particle and any detail of its dynamics, while concerning instead uncertainty ranges only where *any* particle could be found, the indistinguishability of identical particles is already inherent the eqs. (2,1); instead it must be postulated in the standard quantum wave theory. The number n of allowed states is the only way to describe the physical properties of the particle; this explains why n plays in the formulae inferred from eqs. (2,1) the same role of the quantum numbers in the eigenvalues calculated solving the appropriate wave equations [7]. An evidence of this statement is shortly sketched for clarity in section 3.

The generality of eqs. (2,1) has relevant consequences: the approach based on these equations has been extended to the special relativity; instead the momentum and energy operators of eqs. (2,3) have limited worth being inherently non-relativistic. In effect the probabilities Π_x and Π_t have been inferred considering separately time and space; it was already emphasized in [9] that Π_x and Π_t should be merged appropriately into a unique space-time probability $\Pi(x, t)$. The necessity of a combined space-time reference system will be discussed in the next section 3. This fact suggests that a general description of the system is obtainable exploiting directly eqs. (2,1), which by their own definition introduce concurrently both space and time coordinates into the formulation of quantum problems; in short, the present paper upgrades the early concept of uncertainty to that of space-time uncertainty in the way highlighted below.

It has been shown that eqs. (2,1) also entail inherently the concepts of non-locality and non-reality of the quantum world: the observable outcome of a measurement process is actually the result of the interaction between test particle and observer, as a function of which early unrelated space and momentum ranges of the former collapse into smaller ranges actually related to n according to eqs. (2,1); accordingly, it follows that the quantized eigenvalues are compliant with the non-locality and non-reality of quantum mechanics. This collapse is intuitively justified here noting that any measurement process aims to get information about physical observables;

without shrinking the initial unrelated ranges, thus reducing their degree of initial uncertainty, the concept of measurement would be itself an oxymoron. These results prospect therefore a positive expectation of relativistic generalization for the positions (2,2). Due to the subtle character of the connection between quantum and relativistic points of view, the present paper examines more closely in the next section the first consequences of the considerations just carried out, previously obtained in the quoted papers: the first goal to show the successful connection of eqs. (2,1) with the special relativity, is to infer the invariant interval and the Lorentz transformation.

3 Uncertainty and special relativity

The special relativity exploits 4-vectors and 4-tensors that consist of a set of dynamical variables fulfilling well defined transformation rules from one inertial reference system to another. For instance, the components u_i of four velocity are defined by the 4-vector dx_i as $u_i = dx_i(cdt)^{-1}(1 - (v/c)^2)^{-1/2}$, being v the ordinary 3D space velocity; the angular momentum is defined by the anti-symmetric 4-tensor $M^{ik} = \sum(x^i p^k - x^k p^i)$, whose spatial components coincide with that of the vector $\mathbf{M} = \mathbf{r} \times \mathbf{p}$.

Despite the wealth of information available from such definitions, however, the central task always prominent in the present paper concerns their link to the concepts of quantization, non-locality and non-reality that inevitably qualify and testify the sought unification: if the final target is to merge quantum theory and relativity, seems ineffective to proceed on without a systematic check step after step on the compliance of such 4-vectors and tensors with the quantum world.

To explain in general the appropriate reasoning, compare the expectations available via tensor calculus and that available via the positions (2,2): having shown previously that eqs. (2,1) are compliant with the non-reality and non-locality, this means verifying the consistency of the former definitions of angular momentum or velocity with the concept of uncertainty. Since both of them necessarily exploit local coordinates, then, regardless of the specific physical problem to be solved, the previous definitions are in fact useless in the present model; the local coordinates are considered here worthless "a priori" in determining the properties of physical systems and thus disregarded.

Merging quantum and relativistic points of view compels instead to infer the angular momentum likewise as shown in [7], i.e. through its own physical definition via the positions (2,2) to exploit eqs. (2,1). For clarity this topic is sketched in the next sub-sections 3.4 to 3.7 aimed to show that indeed the well known relativistic expressions of momentum, energy and angular momentum of a free particle are inferred via trivial algebraic manipulations of eqs. (2,1) without exploiting the aforesaid standard definitions through local 4-coordinates.

Let us show now that the basic statements of special relativity are corollaries of eqs. (2,1) without any hypothesis on

the uncertainty ranges. First, the previous section has shown that once accepting the positions (2,2) all inertial reference systems are indistinguishable because of the total arbitrariness of their boundary coordinates; if in particular both x_o and t_o are defined with respect to the origin of an inertial space-time reference system R , then the arbitrariness of the former require that of the latter. So in any approach based on eqs (2,1) only, all R are necessarily equivalent in describing the eigenvalues, i.e. the observables of physical quantities. Second, it is immediate to realize that the average velocity $v_x = \Delta x/\Delta t$ previously introduced must be upper bounded. Consider a free particle in finite sized Δx and Δp_x , thus with finite n ; if $v_x \rightarrow \infty$ then $\Delta t \rightarrow 0$ would require $\Delta \varepsilon \rightarrow \infty$, which in turn would be consistent with $\varepsilon \rightarrow \infty$ as well. Yet this is impossible, because otherwise a free particle with finite local momentum p_x could have in principle an infinite energy ε ; hence, being by definition an allowed value of any physical quantity effectively liable to occur, the value of v_x must be upper bound. Third, this upper value allowed to v_x , whatever its specific value might be, must be invariant in any inertial reference system. Indeed v_x is defined in its own R without contradicting the indistinguishability of all reference systems because its value is arbitrary like that of both Δx and Δt ; hence the lack of a definite value of v_x lets R indistinguishable with respect to other inertial reference systems R' whose v'_x is arbitrary as well. If however v_x takes a specific value, called c from now on, then this latter must be equal in any R otherwise some particular $R^{(c)}$ could be distinguishable among any other R' , for instance because of the different rate with which a luminous signal propagates in either of them. Thus: finite and invariant value of c , arbitrariness of the boundary coordinates of Δx and equivalence of all reference systems in describing the physical systems are strictly linked. One easily recognizes in these short remarks, straightforward corollaries of eqs (2,1), the basic statements of the special relativity.

This result legitimates thus the attempt to extend the outcomes of the non-relativistic approach of the early papers [7,8] to the special relativity. Before exemplifying some specific topics in the following subsections, it is useful to note that eqs. (2,1) can be read in several ways depending on how are handled the ranges in a given R .

The first example is provided by the ratio $\Delta x/\Delta t$: if the particle is regarded as a corpuscle of mass m delocalized in Δx , thus randomly moving throughout this range, then $\Delta x/\Delta t$ is its average velocity component v_x during Δt , whatever the local features of actual motion within Δx might be. Interesting results can be inferred hereafter in a straightforward way. It is possible to define $\Delta p_x/\Delta t$ equal to $\Delta \varepsilon/\Delta x$ for any n , thus obtaining the concept of average force field component $F_x = \Delta p_x/\Delta t$ throughout Δx , or the related average power $\Delta \varepsilon/\Delta t = F_x v_x$ and so on. This is not mere dimensional exercise; these definitions hold without specifying a particular reference system and will be exploited in the following to check their ability to get both quantum and relativistic results.

In the next subsection will be examined in particular the ratio $\Delta p_x/\Delta x$ to introduce the curvature of the space-time simply via uncertainty ranges, i.e. in the frame of the uncertainty only. In these expressions, the ranges play the same role of the differentials in the respective classical definitions. This suggests how to regard the concept of derivative entirely in the frame of eqs. (2,1) only, i.e. as ratio of uncertainty ranges. The fact that the size of the ranges is arbitrary suggests the chance of thinking, for mere computational purposes, their limit sizes so small to exploit the previous definitions through the differential formalism; for instance it is possible to imagine a particle delocalized in a very small, but conceptually not vanishing, range dx without contradicting any concept introduced in the positions (2,2), because remains valid in principle the statement $dx\Delta p_x = n\hbar$ despite the random values of x between x_o and $x_o + dx$ tend to the classical local value x_o . It is also possible to define very low values of v_x , i.e. $dx/\Delta t \ll c$, because Δx and Δt are independent ranges and so on. Furthermore, hypothesizing \hbar so small that all ranges can be even treated as differentials, let us try to regard and handle the ranges of eqs. (2,1) as if in the limit case $n = 1$ they would read $(dx)(dp_x) = \hbar = (dt)(d\varepsilon)$. This means that, for mere computational purposes, the case $n = 1$ is regarded as a boundary condition to be fulfilled when calculating the sought physical property.

To check the validity of this point through an example of calculation involving v_x , rewrite eqs. (2,1) in the forms $\Delta p_x/\Delta t = \Delta\varepsilon/\Delta x$ and $\Delta\varepsilon = \Delta p_x\Delta x/\Delta t$ that however will be now handled likewise as if $dp_x/dt = F_x = d\varepsilon/dx$ and $d\varepsilon = v_x dp_x$ to assess the results hereafter obtainable. In agreement with these computational notations, which however do not mean at all regarding the formal position $\Delta x/\Delta t \rightarrow dx/dt$ as a local limit, let us consider a free particle and write

$$\varepsilon = \int v'_x (dp_x/dv'_x) dv'_x. \quad (3,1)$$

Although these positions are here introduced for calculation purposes only, since actually the uncertainty ranges are by definition incompatible with the concept of differential limit size tends to zero, nevertheless it is easy to check their validity recalling that in a previous paper [9] simple considerations based on eqs. (2,1) only allowed to infer $p_x = \varepsilon v_x/c^2$; this equation is so important that its further demonstration based on a different reasoning is also provided below in subsection 3.4. Replacing in eq (3,1) and integrating yields $\varepsilon = c^{-2} \int v'_x [d(\varepsilon v'_x)/dv'_x] dv'_x$, easily solved in closed form; the solution $\varepsilon = const(1 - (v_x/c)^2)^{-1/2}$ yields by consequence also $p_x = v_x c^{-2} const(1 - (v_x/c)^2)^{-1/2}$. If $v_x \rightarrow 0$ then $p_x \rightarrow 0$; yet nothing compels also the vanishing of ε . Calculating thus the limit p_x/v_x for $v_x \rightarrow 0$ and calling m this finite limit,

$$\lim_{v_x \rightarrow 0} \frac{p_x}{v_x} = m, \quad (3,2)$$

one infers the integration constant $const = \pm mc^2$; follow immediately the well known expressions

$$\begin{aligned} p_x &= \pm m v_x (1 - (v_x/c)^2)^{-1/2}, \\ \varepsilon &= \pm m c^2 (1 - (v_x/c)^2)^{-1/2}. \end{aligned} \quad (3,3)$$

The double sign corresponds in the former case to that of either velocity component, in the latter case to the existence of antimatter. Moreover exploit also $\Delta p_x/\Delta t - \Delta\varepsilon/\Delta x = 0$; regarding again this equation in its computational differential form $dp_x/dt - d\varepsilon/dx = 0$ and solving it with respect to v_x , as if the ranges would really be differentials, one finds of course $v_x = -\Delta x/\Delta t$. These results are important: handling the ranges as differentials entails just the well known relativistic results, which appear however to be limit cases i.e. boundary conditions of the respective definitions via uncertainty ranges; this confirms that the intervals appearing in the invariant interval and in the Lorentz transformation of length and time must be actually regarded as uncertainty ranges, as pointed out in [9], so that also the transformation formulae get full quantum meaning. This holds provided that the ranges related to \hbar be really so small with respect to distances and times of interest to justify the integral calculus; this is certainly true in typical relativistic problems that usually concern massive bodies or cosmological distances and times.

So far the particle has been regarded as a corpuscle characterized by a mass m traveling throughout Δx during the time range Δt . According to the positions (2,3) and owing to the results [9], however, the particle can be identically described as a wave propagating throughout the same space range during the same time range; also to this purpose are enough eqs. (2,1), the basic assumptions of the wave formalism are unnecessary.

Let us regard Δx as the space range corresponding to one wavelength and the related Δt as a reciprocal frequency $\omega = \Delta t^{-1}$; so one finds $\Delta\varepsilon = n\hbar\omega$ with $\omega = 2\pi\nu$, in which case $\Delta x/\Delta t = \omega\lambda = v$ as well. In principle one expects from this result that in general an average velocity v_1 corresponds to the frequency ω_1 , thus v_2 to ω_2 and so on. Suppose that, for fixed Δx , a time range $\Delta t'$ and thus a frequency ω' exist such that the right hand side turns into a unique constant velocity, whose physical meaning will appear soon; then, using again the differential formalism, $d(\lambda^{-1}) = -\lambda^{-2}d\lambda$ and $\lambda d\omega' + \omega' d\lambda = 0$ combined into $\lambda(d\omega' - \lambda\omega' d(\lambda^{-1})) = 0$ yield $v'/2\pi = d\omega'/dk$ where $k = 2\pi/\lambda$. Being v' arbitrary like Δx , including the trivial factor 2π in $v'' = v'/2\pi$ yields $v'' = d\omega'/dk$. So are defined the phase and group velocities v and v'' of a wave, which of course coincide if v does not depend on ω ; this is possible because Δx and Δt are independent ranges that can fulfil or not this last particular case. Moreover eqs. (2,1) also yield immediately $\Delta\varepsilon/\Delta p = dv/d(\lambda^{-1}) = v$. Eventually, dividing both sides of $\Delta x\Delta p_x = n\hbar$ by Δt yields

$F\Delta x = n\hbar\omega$; since dF/dv has physical dimension of momentum, being all range sizes arbitrary the last equation reads in general $p = h/\lambda$. These reasonable results are distinctive features of quantum mechanics, here found as corollaries by trivial manipulations of eqs. (2,1). If both corpuscle and wave formalisms are obtained from a unique starting point, eqs. (2,1), then one must accept the corpuscle/wave dual behavior of particles, as already inferred in [9]. This justifies why these equations have been successfully exploited in the early papers [7,8] to describe the quantum systems.

After having checked the compliance of eqs. (2,1) with the fundamental principles of both quantum mechanics and special relativity, we are now justified to proceed further towards the connection between the theories. Eq. (2,1) allow describing various properties of quantum systems, e.g. in the frame of space/time uncertainty or energy/momentum uncertainty, as better specified in the next subsection. Note that the invariant interval, inferred itself from eqs. (2,1) only, is compliant with the non-locality and non-reality simply regarding the space and time intervals as uncertainty ranges; by consequence merging quantum mechanics and special relativity simply requires abandoning the deterministic meaning of intervals defined by local coordinates, which have classical character and thus are exactly known in principle. Indeed we show below that the invariant interval consists of ranges having fully quantum meaning of space-time uncertainty. In the frame of eqs. (2,1) only, the concept of time derivative necessarily involves the time uncertainty range; an example is $\Delta x/\Delta t$ previously identified with the velocity v_x . This latter, even though handled as dx/dt for computational purposes only, still keeps however its physical meaning of average velocity.

These considerations hold in the reference system R where are defined eqs. (2,1) and suggest a remark on the algebraic formalism; once trusting on eqs. (2,1) only, the concept of derivative is replaced by that of ratio between uncertainty ranges. These latter indeed represent the chance of variability of local quantities; so the derivative takes here the meaning of correlation between these allowed chances. Of course being the ranges arbitrary and unknown, this chance is extended also to the usual computational concept of derivative, as shown before. Once having introduced through the uncertainty the requirements of quantum non-locality and non-reality into the relativistic formulae, a problem seems arising at this point, i.e. that of the covariance.

This point will be concerned in the next section 4, aimed to discuss the transformations between inertial and non-inertial reference systems. For clarity of exposition, however, it is better to continue the present introductory discussion trusting to the results so far exposed; it is enough to anticipate here that the arbitrariness of the quantum range boundaries, and thus that of the related reference systems as well, is the key topic to merge the requirements of uncertainty and covariance.

3.1 The space-time uncertainty

This section aims to show that the concept of space-time is straightforward corollary of the space/momentum and time/energy uncertainties. Eq. (2,1) represent the general way of correlating the concepts of space, momentum, time and energy by linking their uncertainties through the number n of allowed states; just their merging defines indeed the eigenvalues of any physical observable. On the one side, therefore, the necessity of considering concurrently both time and space coordinates with analogous physical meaning appears because of the correlation of their uncertainties; for instance the particular link underlying time and space ranges through c allows to infer the invariant interval and the relativistic expressions of momentum and energy. On the other side the concept of quantization appears strictly related to that of space-time, since the concurrence of both Δx and Δt that defines n also introduces in fact a unique space-time uncertainty. These elementary considerations highlight the common root between relativity and quantum theory, which also accounts for the non-locality and non-reality of the latter according to the conclusions emphasized in [9].

Eq. (2,1) consist of two equations that link four ranges; for any n , two of them play the role of independent variables and determine a constrain for the other two, regarded therefore as dependent variables. In principle this means that two independent ranges introduce eqs. (2,1) via n . As Δp_x and $\Delta \varepsilon$ include local values of physical observables while Δx and Δt include local values of dynamical variables, it is reasonable to regard as a first instance just these latter as arbitrary independent variables to which are related momentum and energy as dependent variables for any n ; however any other choice of independent variables would be in principle identically admissible.

For instance, let us concern $\Delta \varepsilon \Delta x / (v_x/c) = n\hbar c$ considering fixed the energy and coordinate ranges. Two limits of this equation are particularly interesting: (i) $v_x/c \rightarrow 0$, which requires in turn $n \rightarrow \infty$, and (ii) $v_x \lesssim c$, which requires $\Delta x \lesssim n\hbar c / \Delta \varepsilon$ for any given n . Consider the former limit rewriting identically $(\Delta p_x / v_x) v_x \Delta x = n\hbar$, which reads $v_x \Delta x \Delta m = n\hbar$ according to eq (3,2); since for a free particle v_x is a constant, then $\Delta(mv_x) = \Delta p_x$ i.e. $p_x \approx mv_x$. Guess the related classical energy regarding again $\Delta \varepsilon / \Delta p_x = v_x$ as $d\varepsilon / dp_x = v_x$, whence $d\varepsilon = v_x m dv_x$ i.e. $\varepsilon = mv_x^2/2 + const$. As expected, these expressions of energy and momentum result to be just the non-relativistic limits of eqs. (3,3) for $v_x \ll c$. This is because we have considered here the space coordinate separately from the time coordinate: despite the time range has been somehow introduced into the previous reasoning through the definition of v_x , yet it occurred in the way typical of the Newtonian mechanics, i.e. regarding the time as an entity separated from the space coordinate, and not through the link between Δp_x and $\Delta \varepsilon$ provided by n .

We also know that the classical physics corresponds to

the limit $n \rightarrow \infty$ [9]; thus eqs. (2,1) require that the non-relativistic limit $v_x \ll c$ and the classical physics limit $n \rightarrow \infty$ are actually correlated. Indeed, eqs. (3,3) have been obtained handling the ranges as differentials just thanks to small values of n . Of course such a correlation is not required when regarding quantum theory and relativity separately, it appears instead here as a consequence of their merging. Since for $n \rightarrow \infty$ the difference between n and $n+1$ becomes more and more negligible with respect to n , this latter tends to behave more and more like a continuous variable. It has been shown in [9] that just the quantization entails the non-real and non-local features of the quantum world; instead locality and reality are asymptotic limit properties of the classical world attained by the continuous variable condition $n \rightarrow \infty$. Now it appears that just the same quantization condition of n requires also the relativistic properties of the particles, which indeed are well approximated by the corresponding equations of Newtonian physics in the limit $n \rightarrow \infty$ i.e. $v_x \ll c$. Otherwise stated, the special relativity rests itself on the quantization condition required by the space/momentum and time/energy uncertainties merged together; these latter are therefore the sought unique fundamental concept on which are rooted quantum properties, non-reality, non-locality and special relativity.

3.2 Energy-momentum uncertainty and Maxwell equations

Let us start from $\Delta\varepsilon = v_x \Delta p_x$; being as usual $\Delta\varepsilon = \varepsilon - \varepsilon_0$ and $\Delta p_x = p_x - p_0$, this uncertainty equation splits into two equations $\varepsilon = v_x p_x$ and $\varepsilon_0 = v_x p_0$ defined by the arbitrary boundary values of energy and momentum. Consider first the former equation; dividing both sides by an arbitrary volume V and by an arbitrary velocity component v_x , the uncertainty equation turns dimensionally into the definition $J_x^{\S} = C^{\S} v_x$ of a mass flow; indeed J_x^{\S} is the flux of the mass m initially defining momentum and energy of the particle, C^{\S} is the corresponding amount of mass per unit volume. Calculating the flux change between any x and $x + \delta x$ during δt , one finds $\delta J_x^{\S} = v_x \delta C^{\S} + C^{\S} \delta v_x$. This result can be exploited in various ways. For instance in a previous paper it has been shown that eqs. (2,1) lead under appropriate hypotheses to the result $J_x^{\S} = -D \partial C^{\S} / \partial x$ [10], being D the diffusion coefficient of m . The particular case of constant v_x in the absence of an external force field acting on m during the time range $\delta t = \delta x / v_x$ yields $\delta J_x^{\S} = -[\partial(D \partial C^{\S} / \partial x) / \partial x] \delta x$. Since $\delta J_x^{\S} / \delta x = -\delta C^{\S} / \delta t$, because $\delta J_x^{\S} / \delta x$ and $\delta C^{\S} / \delta t$ have opposite sign under the hypothesis of gradient driven mass flow in the absence of sinks or sources in the diffusing medium, one obtains the 1D Fick law $\delta C^{\S} / \delta t = \partial(D \partial C^{\S} / \partial x) / \partial x$, trivially extensible to the 3D case. In general, under the constraint of constant v_x only, the vector equations corresponding to $J_x^{\S} = C^{\S} v_x$ and $\delta J_x^{\S} = -v_x \delta C^{\S}$ read

$$\mathbf{J}^{\S} = C^{\S} \mathbf{v}, \quad \nabla \cdot \mathbf{J}^{\S} = -\partial C^{\S} / \partial t. \quad (3,4)$$

Multiplying by e/m both sides of these expressions, one

obtains the corresponding equations for the flux of charge density C_e , i.e. $\mathbf{J}_e = C_e \mathbf{v}$. An analogous result holds for the second part $\varepsilon_0 = v_x p_0$ of the initial uncertainty equation, rewritten now as $\mathbf{J}_m = C_m \mathbf{v}$ with $C_m = C^{\S} e_m / m$; the physical meaning of e_m will be remarked below. Put now $C = C_e + C_m$ and $\mathbf{J} = \mathbf{J}_e + \mathbf{J}_m$; then, replacing \mathbf{J}^{\S} and C^{\S} of the mass concentration gradient equation with \mathbf{J} and C , it is possible to introduce an arbitrary vector \mathbf{U}_- such that the second equation eq (3,4) reads

$$\nabla \cdot \nabla \times \mathbf{U}_- = \nabla \cdot \mathbf{J} + \frac{\partial C}{\partial t} \quad (3,5)$$

as it is clear because the left hand side is null. So one obtains

$$\begin{aligned} \nabla \times \mathbf{U}_- &= \frac{\partial \mathbf{U}_+}{\partial t} + \mathbf{J}, & \nabla \cdot \mathbf{U}_+ &= C, \\ \mathbf{J} &= \mathbf{J}_e + \mathbf{J}_m, & C &= C_e + C_m. \end{aligned} \quad (3,6)$$

The second equation defines \mathbf{U}_+ . Since $C = C_e + C_m$, the vector \mathbf{U}_+ must reasonably have the form $\mathbf{U}_+ = \mathbf{H} + \mathbf{E}$, where \mathbf{H} and \mathbf{E} are arbitrary vectors to be defined. As also \mathbf{J} is sum of two vectors, \mathbf{U}_- is expected to be itself sum of two vectors too. For mere convenience let us define these latter again through the same \mathbf{H} and \mathbf{E} ; there is no compelling reason to introduce necessarily further vectors about which additional hypotheses would be necessary to solve the first eq (3,6). Appears now sensible to guess $\mathbf{U}_- = c(\mathbf{H} - \mathbf{E})$, with c mere dimensional factor, for four reasons: (i) $\mathbf{U}_+ + c^{-1} \mathbf{U}_- = 2\mathbf{H}$ and $\mathbf{U}_+ - c^{-1} \mathbf{U}_- = 2\mathbf{E}$, i.e. \mathbf{U}_- and \mathbf{U}_+ can be expressed through the same vectors they introduce; (ii) the same holds for the scalars $c^{-1} \mathbf{U}_+ \cdot \mathbf{U}_- = H^2 - E^2$ and $U_+^2 - c^{-2} U_-^2 = 4\mathbf{E} \cdot \mathbf{H}$; (iii) the same holds also for $c^{-1} \mathbf{U}_- \times \mathbf{U}_+ = 2\mathbf{E} \times \mathbf{H}$ and (iv) $U_+^2 + c^{-2} U_-^2 = 2(H^2 + E^2)$. If \mathbf{H} and \mathbf{E} are now specified in particular as vectors proportional to magnetic and electric fields, then the proposed definitions of \mathbf{U}_- and \mathbf{U}_+ entail a self-consistent set of scalars and vectors having some interesting features: the scalars (ii) define two invariants with respect to Lorentz transformations, whereas the vector (iii) is proportional to the Poynting vector and defines the energy density flux; moreover the point (iv) defines a scalar proportional to the energy density of the electromagnetic field; eventually the integral $\int \mathbf{U}_+ \cdot \mathbf{U}_- dV$ over the volume previously introduced is proportional to the Lagrangian of a free field.

Although eqs. (3,5) and (3,6) are general equations straightforward consequences of charge flows, simply specifying purposely them to the case of the electromagnetic field follows the validity of the form assigned to \mathbf{U}_- because of such sensible outcomes. The first eq (3,6) reads thus $c \nabla \times (\mathbf{H} - \mathbf{E}) = \partial(\mathbf{H} + \mathbf{E}) / \partial t + (\mathbf{J}_e + \mathbf{J}_m)$. In principle the terms of this equation containing \mathbf{H} , \mathbf{E} , \mathbf{J}_e and \mathbf{J}_m can be associated in various ways, for instance is admissible $c \nabla \times \mathbf{H} = \partial \mathbf{H} / \partial t + \mathbf{J}_m$; integrating this equation is certainly possible but the solution $\mathbf{H} = \mathbf{H}(x, y, z, t, \mathbf{J}_m)$ would be of scarce interest, i.e. one would merely find the space and time profile of a possible

\mathbf{H} consistent with \mathbf{J}_m . The same would hold considering the analogous equation for \mathbf{E} . A combination of mixed terms that appears more interesting is

$$\begin{aligned} \nabla \cdot \mathbf{E} &= C_e, & \nabla \cdot \mathbf{H} &= C_m, \\ -c\nabla \times \mathbf{E} &= \frac{\partial \mathbf{H}}{\partial t} + \mathbf{J}_m, & c\nabla \times \mathbf{H} &= \frac{\partial \mathbf{E}}{\partial t} + \mathbf{J}_e. \end{aligned} \quad (3,7)$$

In this form, the interdependence of the magnetic and electric field vectors \mathbf{H} and \mathbf{E} through \mathbf{J}_e and \mathbf{J}_m yields the Maxwell equations formulated in terms of charge and current densities. These equations, also inferred from eqs. (2,1), have been written having in mind the maximum generality; C_e and C_m are proportional to the electric charge and magnetic charge densities, \mathbf{J}_e and \mathbf{J}_m to the charge and magnetic current densities. While C_e is known, an analogous physical meaning for C_m is doubtful because the magnetic ‘‘monopoles’’ are today hypothesized only but never experimentally observed. Although it is certainly possible to regard these equations with $C_m = 0$ and $\mathbf{J}_m = 0$, nevertheless seems formally attractive the symmetric character of the four equations (3,7). Note however in this respect that rewriting $\mathbf{E} = \mathbf{E}_o + \mathbf{Q}$ and $\mathbf{H} = \mathbf{H}_o + \mathbf{W}$, where \mathbf{W} and \mathbf{Q} are further field vectors whose physical meaning is to be defined, with the positions

$$\begin{aligned} C'_e &= \nabla \cdot \mathbf{Q}, & \nabla \times \mathbf{Q} &= 0, & \mathbf{J}'_e &= \frac{\partial \mathbf{Q}}{\partial t}, \\ \rho_m &= -\nabla \cdot \mathbf{W}, & \nabla \times \mathbf{W} &= 0, & \mathbf{J}'_m &= \frac{\partial \mathbf{W}}{\partial t}, \end{aligned}$$

the equations (3,7) turn into

$$\begin{aligned} \nabla \cdot \mathbf{E}_o &= C_e - C'_e, & \nabla \cdot \mathbf{H}_o &= \rho_m, \\ -c\nabla \times \mathbf{E}_o &= \frac{\partial \mathbf{H}_o}{\partial t} + \mathbf{J}'_m, & c\nabla \times \mathbf{H}_o &= \frac{\partial \mathbf{E}_o}{\partial t} - \mathbf{J}'_e + \mathbf{J}_e, \end{aligned}$$

having put here $C_m = 0$ and $\mathbf{J}_m = 0$. In practice rewriting \mathbf{H} and \mathbf{E} as a sum of vectors \mathbf{H}_o and \mathbf{E}_o parallel to them plus \mathbf{W} and \mathbf{Q} fulfilling the aforesaid conditions one obtains a new set of Maxwell equations whose form, even without reference to the supposed magnetic monopoles, is however still the same as if these latter would really exist. Note eventually that beside eqs. (3,7) there is a further non-trivial way to mix the electric and magnetic terms, i.e.

$$\begin{aligned} \nabla \cdot \mathbf{E} &= C_e, & \nabla \cdot \mathbf{H} &= C_m, \\ -c\nabla \times \mathbf{E} &= \frac{\partial \mathbf{H}}{\partial t} + \mathbf{J}_e, & c\nabla \times \mathbf{H} &= \frac{\partial \mathbf{E}}{\partial t} + \mathbf{J}_m, \end{aligned} \quad (3,8)$$

expectedly to be read with $C_m = 0$ and $\mathbf{J}_m = 0$. Work is in progress to highlight the possible physical meaning of \mathbf{Q} and \mathbf{W} and that of the eqs. (3,8) still consistent with eq (3,6).

3.3 Uncertainty and wave formalism

Start now from eqs. (3,3) that yield $\varepsilon^2 = (cp_x)^2 + (mc)^2$; so the positions (2,3) define the known 2D Klein-Gordon equation $-\partial^2\psi_o/c^2\partial t^2 = -\partial^2\psi_o/\partial x^2 + (mc/\hbar)^2\psi_o$, whose extension to the 4D case is trivial simply assuming $\psi_o = \psi_o(x, y, z, t)$

$$\frac{\partial^2\psi_o}{c^2\partial t^2} - \nabla^2\psi_o + k^2\psi_o = 0, \quad k^2 = \left(\frac{mc}{\hbar}\right)^2. \quad (3,9)$$

Eq. (3,9) is equivalent to $O_5^2\psi_o = 0$ inferred from $O_5\psi_o = 0$, where the total momentum operator O_5 is defined as

$$\begin{aligned} O_5 &= \mathbf{a}_j \frac{\hbar}{i} \frac{\partial}{\partial x_j} + \mathbf{a}_4 \frac{i\hbar}{c} \frac{\partial}{\partial t} + \mathbf{a}_5 mc, \\ j &= 1, 2, 3; \quad \mathbf{a}_j \cdot \mathbf{a}_{j'} = \delta_{j,j'}. \end{aligned}$$

Thus O_5 is the sought linear combination $\mathbf{a}_j P_j + (\mathbf{a}_4 i/c)H + \mathbf{a}_5 mc$ of the momentum P_j and energy H operators (2,3) via orthogonal unit vector coefficients \mathbf{a}_j and $\mathbf{a}_4 i/c$ and \mathbf{a}_5 ; this combination of space and time operators defines the wave equation corresponding to the relativistic eqs. (3,3).

Replace now ψ_o with $\psi = \psi_o + \mathbf{a} \cdot \mathbf{A} + b\varphi$ in eq (3,9); \mathbf{a} and b are arbitrary constants, \mathbf{A} and φ are functions of x_j, t that must still fulfill eq (3,9). Assuming constant both modulus and direction of \mathbf{a} with respect to \mathbf{A} , trivial calculations yield three equations. One is once again the Klein-Gordon equation for ψ_o ; moreover subtracting and summing to the two remainder terms the amount $\mathbf{a} \cdot \mathbf{J}/c$, where \mathbf{J} is a further arbitrary vector, the condition $\mathbf{a} \cdot \mathbf{J}/cb = -\rho$ yields the following two equations

$$\begin{aligned} \frac{\partial^2\varphi}{c^2\partial t^2} - \nabla^2\varphi + k^2\varphi - \rho &= 0, \\ \frac{\partial^2\mathbf{A}}{c^2\partial t^2} - \nabla^2\mathbf{A} + k^2\mathbf{A} - \frac{\mathbf{J}}{c} &= 0. \end{aligned} \quad (3,10)$$

In principle this result is anyway formally possible with the given b , which links the equations through ρ and $\mathbf{J} = \rho\mathbf{v}$ according to eqs. (3,4). The condition on b requires $\mathbf{a} \cdot \mathbf{J}/c\rho = \mathbf{a}' \cdot \mathbf{J}'/c\rho'$; so in general \mathbf{J} is not necessarily a constant. Let us specify now this result. If \mathbf{A} and φ are proportional to the magnetic and electric potentials, then ρ and \mathbf{J} are charge density and flux; in effect the particular case $\varphi \propto r^{-1}$ agrees with the physical meaning of the former, whence the meaning of the latter as well. The fact that ψ_o differs from $\psi = \psi_o + \mathbf{a} \cdot (\mathbf{A} - \mathbf{J}\varphi/c\rho)$ by the vector $\mathbf{A} - \mathbf{J}\varphi/c\rho \neq 0$ suggests defining $\mathbf{a} = \xi\mathbf{J}'/c$ in order obtain the scalar $\mathbf{J}' \cdot \mathbf{A}/c - \varphi\mathbf{J}' \cdot \mathbf{J}/\rho c^2$, i.e. $\mathbf{J}' \cdot \mathbf{A}/c - \rho'\varphi\mathbf{v}' \cdot \mathbf{v}/c^2$; ξ is a proportionality factor. So putting $\varphi = \varphi'q$, with q proportionality factor, the result is $\mathbf{J}' \cdot \mathbf{A}/c - \rho'\varphi'$ with $q^{-1} = \mathbf{v}' \cdot \mathbf{v}/c^2$. In this way one obtains $\psi = \psi_o + \xi(\mathbf{J}' \cdot \mathbf{A}/c - \rho'\varphi')$, while eqs. (3,10) are the well known Proca's equations in vector form.

Note that ξ has physical dimension $field^{-2}$, which indeed justifies the particular way of defining \mathbf{a} , while the scalar in parenthesis characterizes the wave function of a particle moving in the presence of magnetic and electric potentials.

Since a free particle has by definition kinetic energy only, the scalar additive to ψ_o is a perturbative term due to the magnetic and electric potentials; so it should reasonably represent a kinetic energy perturbation due to the presence of magnetic and electric fields. This suggests that the complete Lagrangian $T - U$ of the particle moving in the electromagnetic field should be therefore given by the linear combination of the scalar just found and the free field scalar $c\mathbf{U}_- \cdot \mathbf{U}_+ = H^2 - E^2$, i.e. it should be obtained by volume integration of $\mathbf{J}' \cdot \mathbf{A}/c - \rho'\varphi' + \chi(E^2 - H^2)$, being χ an appropriate coefficient of the linear combination of potential and kinetic energy terms.

This topic is well known and does not deserve further comments. It is worth noticing instead that eqs. (3,10) can be also obtained introducing the extended space-time momentum operator \mathbf{O}_7 collecting together the space and time operators of the positions (2,3) in a unique linear combination expressed as follows

$$\mathbf{O}_7 = \mathbf{a}_j \partial / \partial x_j + \mathbf{a}_4 i \partial / \partial (ct) + \mathbf{a}_5 i / x_5 + \mathbf{a}_6 \partial / \partial x_6 + \mathbf{a}_7 \partial / \partial x_7,$$

where x_5, x_6 and x_7 are to be regarded as extra-coordinates. Putting $x_5 = \hbar/mc$, the wave function that yields directly both eqs. (3,10) with this operator reads accordingly

$$\psi = \psi_o + \mathbf{a} \cdot (\mathbf{A} - \mathbf{J}x_5^2/c)x_6 + (\varphi - \rho x_5^2)x_7.$$

Still holds the position $\mathbf{a}_j \cdot \mathbf{a}_{j'} = \delta_{j,j'}$ that regards again the various \mathbf{a}_j , with $j = 1..7$, as a set of orthogonal unit vectors in a 7D dimensional space where is defined the equation $\mathbf{O}_7^2 \psi = 0$ containing as a particular case the Klein-Gordon equation. The sixth and seventh addends of \mathbf{O}_7 are ineffective when calculating $\mathbf{O}_7^2 \psi_o$, which indeed still yields the free particle equation; however just these addends introduce the non-null terms of Proca's equations in the presence of fields.

In summary, the free particle eq (3,9) is nothing else but the combination of the two eqs. (3,3) expressed through the wave formalism of quantum mechanics; its successive manipulation leads to define the Lagrangian of the electromagnetic field in the presence of magnetic and electric potentials while introducing additional extra-dimensions. It appears however that the chance of defining 3 extra-dimensions to the familiar ones defining the space-time is suggested, but not required in the present model, by the relativistic wave formalism only.

3.4 Uncertainty and invariant interval

In [9] has been inferred the following expression of invariant interval

$$\Delta x^2 - c^2 \Delta t^2 = \delta s^2 = \Delta x'^2 - c^2 \Delta t'^2 \quad (3,11)$$

in two inertial reference systems R and R' . Owing to the fundamental importance of this invariant in special relativity, from which can be inferred the Lorentz transformations [11], we propose here a further instructive proof of eq (3,11) based uniquely on the invariance of c . Consider then the uncertainty range $\Delta x = x - x_o$ and examine how its size might

change during a time range Δt if in general $x = x(\Delta t)$ and $x_o = x_o(\Delta t)$.

Let be $\delta_{\pm} = \Delta x \pm v\Delta t$ the range in R that generalizes the definition $\Delta x/\Delta t = v_x$ to $\delta_{\pm} \neq 0$ through a new velocity component $v \neq v_x$ taking also into account the possible signs of v . Regard both δ_{\pm} as possible size changes of Δx during the time range Δt in two ways: either (i) with x_o replaced by $x_o \pm v\Delta t$ while keeping fixed x or (ii) with x replaced by $x \pm v\Delta t$ while keeping fixed x_o . Of course the chances (i) or (ii) are equivalent because of the lack of hypotheses on Δx and on its boundary coordinates. In both cases one finds indeed $\delta_+ = \Delta x + v\Delta t$ and $\delta_- = \Delta x - v\Delta t$, which yield $\overline{\delta} = (\delta_+ + \delta_-)/2 = \Delta x$; so the range size Δx , seemingly steady in R , is actually a mean value resulting from random displacements of its lower or upper boundaries from x_o or x at average rates $v = \dot{x}_o$ or $v = \dot{x}$ as a function of time. Of course v is in general arbitrary. The actual space-time character of the uncertainty, hidden in $\overline{\delta}$, appears instead explicitly in the geometric mean $\langle \delta \rangle = \langle \delta_- \delta_+ \rangle = (\Delta x^2 - v^2 \Delta t^2)^{1/2}$ of both time deformations allowed to Δx . Note however that the origin O of the reference system R where is defined Δx appears stationary in (ii) to an observer sitting on x_o because is x that displaces, but in (i) O appears moving to this observer at rate $\mp \dot{x}_o$. Consider another reference system R' solidal with x_o , thus moving in R at rates $\pm \dot{x}_o$. In R' is applicable the chance (ii) only, as x_o is constant; it coincides with the origin in R' and, although it does not in R , yet anyway $\dot{x}_o = 0$. So the requirement that both (i) and (ii) must be equivalent to describe the deformation of Δx in R and R' , otherwise these reference systems would be distinguishable, requires concluding that the chance (ii) must identically hold itself both in R and R' . This is possible replacing $v = \dot{x} = c$ in $\langle \delta \rangle$, which indeed makes in this particular case the deformation rate (ii) of Δx indistinguishable in R and R' : in both systems $\dot{x}_o = 0$, as x_o is by definition constant, whereas \dot{x} also coincides because of the invariance of c ; when defined through this particular position, therefore, $\langle \delta^{(c)} \rangle$ is invariant in any R and R' in agreement with eqs. (3,11). These equations have been written considering spacelike intervals; of course an identical reasoning holds also writing eqs. (3,11) as timelike intervals.

3.5 The invariance of eqs. (2,1)

The following considerations concern the invariance of eqs. (2,1) in different inertial reference systems. The proof is based on the arbitrariness of the range sizes and on the fact that in any R and R' actually n is indistinguishable from n' pertinent to the different range sizes resulting from the Lorentz transformations; indeed neither n nor n' are specified and specifiable by assigned values, rather they symbolize arbitrary numbers of states. Admitting different range sizes in inertial reference systems in reciprocal motion, the chance of any n in R corresponds to any other chance allowed to n' in R' . However the fact that the ranges are arbitrary compels

considering the totality of values of n and n' , not their single values, in agreement with the physical meaning of eqs. (2,1). Hence, despite the individual numbers of states can be different for specific $\Delta x \Delta p_x$ in R and $\Delta x' \Delta p'_x$ in R' , the sets of all arbitrary integers represented by all n and n' remain in principle indistinguishable regardless of how any particular n might transform into another particular n' .

The fact of having inferred in [9] the interval invariant in inertial reference systems, the Lorentz transformations of time and length and the expression $p_x = \varepsilon v_x / c^2$, should be itself a persuasive proof of the compliance of eqs. (2,1) with special relativity; now it is easy to confirm this conclusion demonstrating the expression of p_x in a more straightforward way, i.e. exploiting uniquely the concept of invariance of c . The present reasoning starts requiring an invariant link between $\Delta p_x = p_1 - p_0$ and $\Delta \varepsilon = \varepsilon_1 - \varepsilon_0$ in $\Delta \varepsilon = \Delta p_x \Delta x / \Delta t$. This is possible if $\Delta x / \Delta t = c$, hence $\Delta p_x c = \Delta \varepsilon$ is a sensible result: it means of course that any local value ε within $\Delta \varepsilon$ must be equal to $c p_x$ calculated through the corresponding local value p_x within Δp_x although both are unknown. If however $\Delta x / \Delta t < c$, the fact that the arbitrary v_x is not an invariant compels considering for instance $v_x^k \Delta x / \Delta t = q c^{k+1}$ with k arbitrary exponent and $q < 1$ arbitrary constant. Then $(\Delta p_x v_x^{-k}) c^{k+1} q = \Delta \varepsilon$ provides in general an invariant link of $\Delta p_x v_x^{-k}$ with $\Delta \varepsilon$ through $c^{k+1} q$. Is mostly interesting the chance $k = 1$ that makes the last equation also consistent with the previous particular case, i.e. $(\Delta p_x / v_x) c^2 q = \Delta \varepsilon$; so one finds $\varepsilon_1 v'_x / c^2 - p_1 = \varepsilon_0 v'_x / c^2 - p_0$ with $v'_x = v_x / q$. The arbitrary factor q is inessential because v_x is arbitrary itself, so it can be omitted; hence $p_x = \varepsilon v_x / c^2$ when considering any local values within the respective ranges because of the arbitrariness of $p_0, p_1, \varepsilon_0, \varepsilon_1$. At this point holds identically the reasoning of the previous subsection. Rewrite $\Delta \varepsilon - (\Delta p_x / v_x) c^2 = 0$ as $\delta_{\pm} = \Delta \varepsilon \pm (\Delta p_x / v) c^2 \neq 0$ with $v \neq v_x$ to calculate $\overline{\delta} = \Delta \varepsilon$ and $< \delta \varepsilon > = \pm \sqrt{\Delta \varepsilon^2 - (\Delta p_x / v)^2 c^4}$; one concludes directly that the invariant quantity of interest is that with $v = c$, i.e. $\delta \varepsilon_c = \pm \sqrt{\Delta \varepsilon^2 - \Delta p_x^2 c^2}$ that reads

$$\Delta \varepsilon^2 = \delta \varepsilon_c^2 + \Delta p_x^2 c^2. \tag{3,12}$$

So $\varepsilon^2 = (m c^2)^2 + p_x^2 c^2$ once having specified $\delta \varepsilon_c$ with the help of eq (3,2). This is not a trivial way to obtain again eqs (3,3). In general the ranges are defined by arbitrary boundary values; then ε_1 and ε_0 can be thought in particular as arbitrary values of ε , thus invariant themselves if calculated by means of eqs. (3,3). So, despite the local values within their own uncertainty ranges are unknown, the range $\Delta \varepsilon$ defined as the difference of two invariant quantities must be invariant itself. Consider thus in particular the interval of eq (3,11). It is interesting to rewrite this result with the help of eqs. (2,1) as $(n \hbar)^2 \Delta p_x^{-2} - c^2 (n \hbar)^2 \Delta \varepsilon^{-2} = \delta s^2 = \Delta x'^2 - c^2 \Delta t'^2$, which yields therefore

$$\delta p_x \delta s = n \hbar = \delta p'_x \delta s, \tag{3,13}$$

$$\delta p_x = \pm \frac{\Delta p_x \Delta \varepsilon}{\sqrt{\Delta \varepsilon^2 - (c \Delta p_x)^2}}, \quad \delta p'_x = \pm \frac{\Delta p'_x \Delta \varepsilon'}{\sqrt{\Delta \varepsilon'^2 - (c \Delta p'_x)^2}}.$$

So $\delta p_x = \delta p_x(\Delta p_x, \Delta \varepsilon)$, whereas $\delta p'_x = \delta p'_x(\Delta p'_x, \Delta \varepsilon')$ as well. Both δs and δp_x at left hand side are invariant: the former by definition, the latter because formed by quantities $\Delta \varepsilon$ and Δp_x defined by invariant boundary quantities $\varepsilon_1, \varepsilon_0, p_1, p_0$ of the eqs. (3,3). Being the range sizes arbitrary and not specifiable in the present theoretical model, the first eq. (3,13) is nothing else but the first eqs. (2,1) explicitly rewritten twice with different notation in invariant form. This feature of the first eq. (3,13) confirms not only the previous reasoning on n and n' , thus supporting the relativistic validity of eqs. (2,1) in different inertial reference systems, but also the necessity of regarding the ranges of special relativity as uncertainty ranges; in other words the concept of invariance merges with that of total arbitrariness of n , on which was based the previous reasoning. In conclusion: (i) disregarding the local coordinates while introducing the respective uncertainty ranges according to the positions (2,2) is enough to plug the classical physics into the quantum world; (ii) replacing the concepts of space uncertainty and time uncertainty with that of space-time uncertainty turns the non-relativistic quantum physics into the relativistic quantum physics; (iii) the conceptual step (ii) is fulfilled simply considering time dependent range sizes; (iv) if the deterministic intervals of special relativity are regarded as uncertainty ranges, then the well known formulae of special relativity are in fact quantum formulae that, as a consequence of eqs. (2,1), also fulfil the requirements of non-locality and non-reality. Accordingly, it is not surprising that the basic postulates of special relativity are in fact corollaries of eqs. (2,1) only, without the need of any further hypothesis.

3.6 The angular momentum

Let us show how the invariant interval of eq (3,11) leads to the relativistic angular momentum. Expand in series the range $\delta s = \sqrt{\Delta x^2 - c^2 \Delta t^2}$ noting that in general

$$\sqrt{a^2 - b^2} = a - \left(b/a + (b/a)^3/4 + (b/a)^5/8 + \dots \right) b/2.$$

Calculated with an arbitrary number of terms, the series expansion can be regarded as an exact result. Thus write $\delta s = \delta r_x - \delta r_t / 2$ where $\delta r_t = c \Delta t \left[c \Delta t / \Delta x + (c \Delta t / \Delta x)^3 / 4 + \dots \right]$ and $\delta r_x = \Delta x$. Being Δt and Δx both arbitrary, δr_x and δr_t are independent ranges. Regard δs as the x -component of an arbitrary uncertainty vector range $\delta \mathbf{s} = \delta \mathbf{r}_s - \delta \mathbf{r}_t / 2$ and repeat identically the reasoning introduced in [7] and shortly sketched here; the subscripts stand for "space" and "time". Insert $\delta \mathbf{s}$ in the classical component $M_w = \delta \mathbf{s} \times \delta \mathbf{p} \cdot \mathbf{w}$ of angular momentum \mathbf{M} along the arbitrary unit vector \mathbf{w} . The analytical form of the function expressing the local value \mathbf{p} does not need to be specified; according to the positions (2,2) \mathbf{p} is a random value to be replaced by its own uncertainty

range $\delta\mathbf{p}$ to find the eigenvalues of the angular momentum. For the mere fact of having introduced an invariant interval into the definition of angular momentum, therefore, M_w results defined by the sum of two scalars $M_{w,s} = \delta\mathbf{r}_s \times \delta\mathbf{p} \cdot \mathbf{w}$ and $M_{w,t} = -\delta\mathbf{r}_t \times \delta\mathbf{p} \cdot \mathbf{w}/2$. So $M_{w,s} = \mathbf{w} \times \delta\mathbf{r}_s \cdot \delta\mathbf{p}$, i.e. $M_{w,s} = \delta\mathbf{p} \cdot \delta\mathbf{I}_s$ with $\delta\mathbf{I}_s = \mathbf{w} \times \delta\mathbf{r}_s$. If $\delta\mathbf{p}$ and $\delta\mathbf{I}_s$ are orthogonal then $M_{w,s} = 0$; else $M_{w,s} = \delta p_{I_s} \delta I_s$, defined by the conjugate dynamical variables $\delta p_{I_s} = \delta\mathbf{p} \cdot \delta\mathbf{I}_s / |\delta\mathbf{I}_s|$ and $\delta I_s = |\delta\mathbf{I}_s|$, yields immediately by virtue of eqs. (2,1) $M_{w,s} = \pm\hbar$ with l arbitrary integer including zero; instead of n , we have used the standard notation l for the eigenvalues of angular motion of the particle. Identically one finds also $M_{w,t} = \pm l'\hbar/2$, with l' arbitrary integer including zero too. Hence $M_w = \pm\hbar \pm l'\hbar/2$.

The first addend is clearly the non-relativistic component \hbar of angular momentum already found in [7], the latter yields an additional component $l'\hbar/2$ of angular momentum. Having considered the invariant range δs rather than the space range Δx only, the further number l' of states is due to the time term of the space-time uncertainty; putting $\Delta t = 0$, i.e. omitting the time/energy uncertainty and thus the time coordinate, $\delta r_t = 0$ and M_w coincides with the non-relativistic quantum component of angular momentum only.

Four important remarks concern:

(i) the number l of states allowed for the non-relativistic angular momentum component coincides with the quantum number of the eigenvalue of the non-relativistic angular momentum wave equation;

(ii) the concept of space-time uncertainty defines the series development of the particular invariant range δs as sum of two terms, the second of which introduces a new non-classical component of angular momentum $l'/2$;

(iii) the local momentum \mathbf{p} and local coordinate \mathbf{s} within the ranges $\delta\mathbf{p}$ and $\delta\mathbf{s}$ are not really calculated, rather they are simply required to change randomly within the respective ranges of values undetermined themselves; (iv) the boundary coordinates of both $\delta\mathbf{p}$ and $\delta\mathbf{s}$ do not appear in the result, rather is essential the concept of delocalization ranges only to infer the total component as a sum of both eigenvalues.

The component $M_w = \pm\hbar \pm s\hbar$, with $s = l'/2$, requires introducing $\mathbf{M} = \mathbf{L} + \mathbf{S}$. In [7] the non-relativistic M_{nr}^2 has been calculated summing its squared average components between arbitrary values $-L$ and $+L$ allowed for $\pm l$, with L by definition positive, thus obtaining $M_{nr}^2 = 3 < (\hbar l)^2 > = L(L+1)\hbar^2$. Replace now $\pm l$ with $\pm l \pm s$; with $j = l \pm s$ ranging between arbitrary $-J$ and J , then $M^2 = 3 < (\hbar j)^2 > = 3(2J+1)^{-1} \sum_{-J}^J (\hbar j)^2 = \hbar^2 J(J+1)$ being J positive by definition. The obvious identity $\sum_{-J}^J j^2 \equiv 2 \sum_0^J j^2$ requires that J consistent with M^2 takes all values allowed to $|j|$ from $|l-s|$ up to $|l+s|$ with $l \leq L$ and $s \leq S$. Since no hypothesis has been made on \mathbf{L} and \mathbf{S} , this result yields in general the addition rule of quantum vectors. Also, holds for \mathbf{S} the same reasoning car-

ried out for \mathbf{L} in [7], i.e. only one component of \mathbf{S} is known, whereas it is immediate to realize that $S^2 = \hbar^2(L'/2+1)L'/2$.

The physical meaning of \mathbf{S} appears considering that: (i) $l'\hbar/2$ is an angular momentum, inferred likewise as and contextually to \hbar ; (ii) l' results when considering the invariant space-time uncertainty range into the definition of M_w ; (iii) l and l' are independent, indeed they concern two independent uncertainty equations; the former is related to the angular motion of the particle, the latter must be instead an intrinsic property of the particle, as l' is defined regardless of whether $l = 0$ or $l \neq 0$. Since in particular $l' \neq 0$ even though the orbital angular momentum is null, \mathbf{S} can be nothing else but the intrinsic property of the particle we call spin angular momentum. Indeed it could be also inferred in the typical way of reasoning of the special relativity i.e. introducing observers and physical quantities in two different inertial reference systems R and R' in relative constant motion; so, exploiting exactly the same procedure considering couples $\delta\mathbf{r}$ and $\delta\mathbf{p}$ together with $\delta\mathbf{r}'$ and $\delta\mathbf{p}'$ fulfilling the Lorentz transformation one finds of course the same result.

It is significant the fact that here the spin is inferred through the invariant interval of eq (3,13), i.e. exploiting eqs. (2,1) only. This is another check of the conceptual compliance of these equations with the special relativity.

3.7 The hydrogenlike atom/ion

The following example of calculation concerns first the non-relativistic hydrogenlike atom/ion. Assume first the origin O of R on the nucleus, the energy is thus $\varepsilon = p^2/2m - Ze^2/r$ being m the electron mass. Since $p^2 = p_r^2 + M^2/r^2$, the positions (2,2) $p_r \rightarrow \Delta p_r$ and $r \rightarrow \Delta r$ yield $\varepsilon = \Delta p_r^2/2m + M^2/2m\Delta r^2 - Ze^2/\Delta r$. Two numbers of states, i.e. two quantum numbers, are expected because of the radial and angular uncertainties. Eqs. (2,1) and the results of section 3.3 yield $\varepsilon = n^2\hbar^2/2m\Delta r^2 + l(l+1)\hbar^2/2m\Delta r^2 - Ze^2/\Delta r$ that reads $\varepsilon = \varepsilon_o + l(l+1)\hbar^2/2m\Delta r^2 - E_o/n^2$ with $E_o = Z^2e^4m/2\hbar^2$ and $\varepsilon_o = (n\hbar/\Delta r - Ze^2m/n\hbar)^2/2m$. Minimize ε putting $\varepsilon_o = 0$, which yields $\Delta r = n^2\hbar^2/Ze^2m$ and $\varepsilon_{tot} = [l(l+1)/n^2 - 1]E_o/n^2$; so $l \leq n-1$ in order to get $\varepsilon < 0$, i.e. a bound state. Putting thus $n = n_o + l + 1$ one finds the electron energy levels $\varepsilon_{el} = -E_o/(n_o + l + 1)^2$ and the rotational energy $\varepsilon_{rot} = l(l+1)E_o/n^4$ of the atom/ion as a whole around O . So $\varepsilon_{rot} = \varepsilon_{tot} - \varepsilon_{el}$. Repeat the same reasoning putting O on the center of mass of the system nucleus + electron; it is trivial to infer $E'_o = Z^2e^4m_r/2\hbar^2$ and $\Delta r' = n^2\hbar^2/Ze^2m_r$, being m_r the electron-nucleus reduced mass. If instead O is fixed on the electron, i.e. the nucleus moves with respect to this latter, then $E''_o = Z^2e^4A/2\hbar^2$ and $\Delta r'' = n^2\hbar^2/Ze^2A$, being A the mass of the nucleus. Thus various reference systems yield the same formula, and then again $\varepsilon'_{rot} = \varepsilon'_{tot} - \varepsilon'_{el}$ and $\varepsilon''_{rot} = \varepsilon''_{tot} - \varepsilon''_{el}$, yet as if the numerical result would concern particles of different mass.

The ambiguity between change of reference system and

change of kind of particle is of course only apparent; it depends merely on the erroneous attempt of transferring to the quantum world dominated by the uncertainty the classical way of figuring an “orbital” system of charges where one of them really rotates around the other. Actually the uncertainty prevents such a phenomenological way of thinking: instead the correct idea is that exists a charge located somewhere with respect to the nucleus and interacting with it, without chance of specifying anything else. This is shown noting that anyway one finds $E_{el} = -Ze^2/2\Delta\rho$ with $\Delta\rho$ symbolizing any radial range of allowed distances between the charges, regardless of which particle is actually in O . Since the total uncertainty range $2\Delta\rho$ is the diameter of a sphere centered on O , the different energies are mere consequence of different delocalization extents of a unique particle with respect to any given reference point.

This reasoning shows that different ranges of allowed radial momenta entail different allowed energies: if the particle of mass m is replaced for instance by one of lower mass, then $\Delta\rho$ increases while therefore Δp_ρ decreases; i.e. E_o reasonably decreases along with the range of allowed radial momenta. Of course it is not possible to infer “a priori” if these outcomes concern the motion of three different particles or the motion of a unique particle in three different reference systems; indeed no specific mass appears in the last conclusion. The allowed radial momenta only determine ε_{el} , defined as $-E_o$ of two charges $-Ze$ and e at diametric distance with respect to O times n^{-2} ; this latter is the fingerprint of the quantum delocalization meaning of $\Delta\rho$. So E_o is defined by the mass m of the particle whose energy levels are of interest; for instance in the case of a mesic atom m would be the mass of a negative muon.

Note that ε_{el} is the intrinsic energy of the system of two charges, regardless of the kinetic energy of the atom as a whole and the rotational energy, i.e. $\Delta\varepsilon = \varepsilon_{tot} - \varepsilon_{el} = l(l+1)E_o/n^2$. The physical meaning of the boundary coordinates of Δx and Δt has been already emphasized.

Let us consider now the boundary values of other uncertainty ranges, examining also the harmonic oscillator and the angular momentum. The vibrational and zero point energies of the former $n\hbar\omega$ and $\hbar\omega/2$ define $\Delta\varepsilon = \varepsilon_{tot} - \varepsilon_{zp} = n\hbar\omega$; i.e. the lower boundary of the range is related to an intrinsic energy not due to the oscillation of the mass, likewise as that of the hydrogenlike atom was the binding energy. In the case of angular momentum $\Delta M_w = M_w - l\hbar = l\hbar$, with $M_w \equiv M_{tot,w}$, i.e. the lower boundary of the range is still related to the intrinsic angular momentum component of the particle; from this viewpoint, therefore, the spin is understandable as the intrinsic property not dependent on the specific state of motion of the particle with respect to which the arbitrary values of l define the range size ΔM_w . The same holds for the relativistic kinetic energy of a free particle; the series development of the first eq (3.3) shows that its total energy is the rest energy plus higher order terms, i.e. one expects $\Delta\varepsilon = \varepsilon - mc^2$; also

now the lower boundary of the range is an intrinsic feature of the particle, not related to its current state of motion. Classically, the energy is defined an arbitrary constant apart; here it appears that this constant is actually an intrinsic property of the particle, not simply a mathematical requirement, and that a similar conclusion should hold in general, thus expectedly also for the relativistic hydrogenlike energy. Let us concern the relativistic case specifying the energy ranges in order to infer the binding energy $\varepsilon_{el} < 0$ through trivial manipulations of eq (3.12) $\Delta\varepsilon^2 = c^2\Delta p^2 + \delta\varepsilon_c^2$. This expression is the 4D extension of that considering the component Δp_x only; whatever the three space components and their link to Δp might be, their arbitrariness allows to write again $\Delta p = p_1 - p_o$ and $\Delta\varepsilon = \varepsilon_1 - \varepsilon_o$. The first steps of calculations are truly trivial: consider $c\Delta p/\delta\varepsilon_c$ then calculate $(c\Delta p - \Delta\varepsilon)/\delta\varepsilon_c$, so that $(cp_1 - \Delta\varepsilon)/\delta\varepsilon_c = b + \sqrt{a^2 - 1} - a$ with $a = \Delta\varepsilon/\delta\varepsilon_c$ and $b = cp_o/\delta\varepsilon_c$. Next $(cp_1 - \Delta\varepsilon)^2/\delta\varepsilon_c^2$ yields trivially

$$\frac{\Delta\varepsilon^2}{(cp_1 - \Delta\varepsilon)^2} - \frac{(c\Delta p)^2}{(cp_1 - \Delta\varepsilon)^2} = \frac{1}{(b + \sqrt{a^2 - 1} - a)^2}.$$

A reasonable position is now $(cp_1 - \Delta\varepsilon)^2 = (c\Delta p)^2$: indeed the left hand side $\Delta\varepsilon^2/(c\Delta p)^2 = 1$ for $b \rightarrow \infty$, i.e. for $\delta\varepsilon_c \rightarrow 0$, agrees with the initial equation. Trivial manipulations yield

$$\frac{cp_1}{\Delta\varepsilon} = 1 \pm \frac{1}{\sqrt{1 + (b + \sqrt{a^2 - 1} - a)^{-2}}},$$

$$c\Delta p = \pm(cp_1 - \Delta\varepsilon), \quad a = \frac{\Delta\varepsilon}{\delta\varepsilon_c}, \quad b = \frac{cp_o}{\delta\varepsilon_c}.$$

This result has not yet a specific physical meaning because it has been obtained simply manipulating the ranges $\Delta\varepsilon$, $\delta\varepsilon_c$ and $c\Delta p$. Physical information is now introduced taking the minus sign and calculating the non-vanishing first order term of series development of the right hand side around $b = \infty$, which is $1/2b^2$; the idea that specifies the result is thus the non-relativistic hydrogenlike energy $-(\alpha Z/n)^2 mc^2/2$ previously found. Requiring $b = n/\alpha Z$, the limit of the ratio $cp_1/\Delta\varepsilon$ is thus the energy in mc^2 units gained by the electron in the bound state with respect to the free state. To infer a recall that $n = l + 1$ and note that the second equation $\pm\Delta\varepsilon = cp_o - cp_1 \pm cp_1$ reads $\pm\Delta\varepsilon = cp_o$ or $\pm\Delta\varepsilon = cp_o - 2cp_1$; dividing both sides by $\delta\varepsilon_c$, the latter suggests $cp_1/\delta\varepsilon_c = (2\alpha Z)^{-1}$ in order that $\pm a = n/\alpha Z$ or $\pm a = (n-1)/\alpha Z$ read respectively $\pm a = (l+1)/\alpha Z$ or $\pm a = l/\alpha Z$, i.e. $a = (l+1/2 \pm 1/2)/\alpha Z$.

In conclusion the relativistic form of the binding energy ε_{el} is

$$\frac{\varepsilon_{el}}{mc^2} = \sqrt{1 + \frac{(\alpha Z)^2}{\left(n + \sqrt{(j+1/2)^2 - 1} - (j+1/2)\right)^2} - 1}$$

with $j = l \pm s$. If $n \rightarrow \infty$ then $\varepsilon_{el} \rightarrow 0$, while the non-relativistic limit previously found corresponds to $\alpha Z \rightarrow 0$.

3.8 The pillars of quantum mechanics

Let us show now that the number of allowed states introduced in eqs. (2,1) leads directly to both quantum principles of exclusion and indistinguishability of identical particles. The results of the previous section suggest the existence of different kinds of particles characterized by their own values of l' . If this conclusion is correct, then the behavior of the particles should depend on their own l' . Let us consider separately either possibility that l' is odd or even including 0.

If $l'/2$ is zero or integer, any change of the number N of particles is physically indistinguishable in the phase space: are indeed indistinguishable the sums $\sum_{j=1}^N l_j + Nl'/2$ and $\sum_{j=1}^{N+1} l_j^* + (N+1)l'/2$ controlling the total value of M_w before and after increasing the number of particles; indeed the respective l_j and l_j^* of the j -th particles are arbitrary. In other words, even after adding one particle to the system, M_w and thus M^2 replicate any possible value allowed to the particles already present in the system simply through a different assignment of the respective l_j ; so, in general a given number of allowed states determining M_w is not uniquely related to a specific number of particles.

The conclusion is different if l' is odd and $l'/2$ half-integer; the states of the phase space are not longer indistinguishable with respect to the addition of particles since M_w jumps from ... integer, half-integer, integer... values upon addition of each further particle, as any change of the number of particles necessarily gives a total component of M_w , and then a resulting quantum state, different from the previous one. In other words any odd- l' particle added to the system entails a new quantum state distinguishable from those previously existing, then necessarily different from that of the other particles. The conclusion is that a unique quantum state is consistent with an arbitrary number of even- l' particles, whereas a unique quantum state characterizes each odd- l' particle. This is nothing else but a different way to express the Pauli exclusion principle, which is thus corollary itself of quantum uncertainty. Recall also the corollary of indistinguishability of identical particles, already remarked; eqs. (2,1) concern neither the quantum numbers of the particles themselves nor their local dynamical variables but ranges where *any* particle could be found, whence the indistinguishability.

We have shown that a unique formalism based on eqs. (2,1) only is enough to find the basic principles of both special relativity and quantum mechanics; also, quantum and relativistic results have been concurrently inferred. The only essential requirement to merge special relativity and quantum mechanics is to regard the intervals of the former as the uncertainty ranges of the latter. The next step concerns of course the general relativity.

4 Uncertainty and general relativity

In section 3 the attempt to generalize the non-relativistic results of the papers [7,8] was legitimated by the possibility of

obtaining preliminarily the basic postulates of special relativity as straightforward corollaries of eqs. (2,1). Doing so, the positions (2,2) ensure that the special relativity is compliant with the concepts of quantization, non-reality and non-locality of quantum mechanics [9]. At this point, the attempt of extending further an analogous approach to the general relativity is now justified by showing two fundamental corollaries: (i) the equivalence of gravitational and inertial forces and (ii) the coincidence of inertial and gravitational mass. These concepts, preliminarily introduced in [9], are so important to deserve being sketched again here.

Once accepting eqs. (2,1) as the unique assumption of the present model, the time dependence of the uncertainty range sizes $\Delta x = x - x_o$ and $\Delta p_x = p_x - p_o$ rests on their link to Δt through n ; for instance it is possible to write $d\Delta x/d\Delta t$ in any R without contradicting eqs. (2,1); this position simply means that changing Δt , e.g. the time length allowed for a given event to be completed, the space extent Δx necessary for the occurring of that event in general changes as well. In other words there is no reason to exclude that $\Delta t \rightarrow \Delta t + \Delta t^{\S}$, with Δt^{\S} arbitrary, affects the sizes of Δx and Δp_x although n remains constant; in fact eqs. (2,1) do not prevent such a possibility. Hence, recalling that here the derivative is the ratio of two uncertainty ranges, the rate $\Delta \dot{x}$ with which changes Δx comes from the chance of assuming $\dot{x} = \delta x/d\Delta t$ and/or $\dot{x}_o = \delta x_o/d\Delta t$; also, since analogous considerations hold for $d\Delta p_x/d\Delta t$ one finds similarly \dot{p}_x and \dot{p}_o . Also recall that the boundary values of the ranges are arbitrary, so neither p_o and p_x nor their time derivatives need to be specified by means of assigned values. Since \dot{p}_o and \dot{p}_x are here simply definitions, introduced in principle but in fact never calculated, the explicit analytical form of the momentum p of general relativity does not need to be known; the previous examples of angular momentum and hydrogenlike atoms elucidate this point. The following reasoning exploits therefore the mere fact that a local force is related to a local momentum change, despite neither the former nor the latter are actually calculable functions of coordinates.

Let us define Δt and the size change rates $d\Delta x/d\Delta t$ and $d\Delta p_x/d\Delta t$ in an arbitrary reference system R as follows

$$d\Delta p_x/d\Delta t = F = -n\hbar\Delta x^{-2}d\Delta x/d\Delta t \quad (4,1)$$

with $F \neq 0$ provided that $\dot{x} \neq \dot{x}_o$ and $\dot{p}_x \neq \dot{p}_o$. At left hand side of eqs. (4,1) the force component F involves explicitly the mass of the particle through the change rate of its momentum; at the right hand side F concerns the range Δx and its size change rate only, while the concept of mass is implicitly inherent the physical dimensions of \hbar . It is easy to explain why a force field arises when changing the size of Δx : this means indeed modifying also the related size of Δp_x and thus the extent of values allowed to the random p_x ; the force field is due to the resulting \dot{p}_x throughout Δx whenever its size is altered. After having acknowledged the link between $\Delta \dot{x}$ and

F intuitively suggested by eqs. (2,1), the next task is to check the conceptual worth of eqs. (4,1). Let x_o be the coordinate defined with respect to the origin O of R where hold eqs. (2,1). If $\Delta t = t - t_o$ with $t_o = const$, then the previous expression reads $d\Delta p_x/dt = F = -n\hbar\Delta x^{-2}d\Delta x/dt$. Formally eqs. (4,1) can be rewritten in two ways depending on whether x_o or x , and likewise p_o or p_x , are considered constants: either (i) $\Delta\dot{p}_x \equiv \dot{p}_x$ so that $\dot{p}_x = F_x = -n\hbar\Delta x^{-2}\dot{x}$ or (ii) $\Delta\dot{p}_x \equiv \dot{p}_o$ so that $\dot{p}_o = F_o = -n\hbar\Delta x^{-2}\dot{x}_o$.

The physical meaning of these results is realized imagining in R the system observer + particle: the former is sitting on x_o , the latter is fixed on x . In (i) the observer is at rest with respect to O and sees the particle accelerating according to \dot{p}_x by effect of F_x generated in R during the deformation of the space-time range Δx . In (ii) the situation is different: now Δx deforms while also moving in R at rate \dot{x}_o with respect to O , the deformation occurs indeed just because the particle is at rest with respect to O ; thus the force F_o displaces the observer sitting on x_o , which accelerates with respect to the particle and to O according to $-\dot{p}_o$. In a reference system R_o solidal with x_o , therefore, a force F'_o still acts on the observer although he is at rest; the reason is clearly that R_o is non-inertial with respect to R because of its local acceleration related to $-\dot{p}_o$. Although the reasoning is trivially simple, the consequence is important: both situations take place in the presence of a force component because both cases (i) and (ii) are equally allowed and conceptually equivalent; however the force in R is real, it accelerates a mass, that in R_o does not; yet $F_x \neq 0$ compels admitting in R also $F_o \neq 0$, which in turn reads $F'_o \neq 0$ in R_o . Whatever the transformation rule from F_o to F'_o might be, the conclusion is that an observer in an accelerated reference frame experiences a force similar to that able to accelerate a massive particle with respect to the observer at rest. Of course F_x is actually the component of a *force field*, because it is an average value defined throughout a finite sized range Δx deforming as a function of time, whereas F_o and F'_o are by definition *local* forces in x_o ; if however the size of Δx is smaller and smaller, then F_x is better and better defined itself like a classical local force.

Now we are also ready to find the equivalence between inertial and gravitational mass. Note indeed that F_x has been defined through a unique mass m only, that appearing in the expression of momentum; hence from the standpoint of the left hand side of eqs. (4,1) we call m inertial mass. Consider in this respect that just this mass must somehow appear also at right hand side of eqs. (4,1) consisting of uncertainty ranges only, which justifies the necessary position $n\hbar\Delta\dot{x}\Delta x^{-2} = m \sum_{j=2}^{\infty} a_j\Delta x^{-j}$ according which the mass is also an implicit function of Δx , $\Delta\dot{x}$, \hbar and n ; the lower summation index is due to the intuitive fact that $\Delta\dot{x}$ cannot be function of or proportional to Δx otherwise it would diverge for $\Delta x \rightarrow \infty$, hence the power series development of the quantity at left hand side must start from Δx^{-2} . So, putting as usual the coefficient of the first term of the series $a_2 = k_G$, eqs. (4,1)

yields $F = -k_G m \Delta x^{-2} + m a_3 \Delta x^{-3} + \dots$. Three remarks on this result are interesting: (i) the first term is nothing else but the Newton gravity field, where now the same m plays also the expected role of gravitational mass generating a radial force that vanishes with x^{-2} law if expressed through the local radial distance x from m ; (ii) F is in general additive at the first order only, as it is evident considering the sum of $\Delta\dot{x}_1$ due to F_1 related to m_1 plus an analogous $\Delta\dot{x}_2$ due to F_2 in the presence of another mass m_2 ; (iii) gravitational mass generating F and inertial mass defined by \dot{p}_o coincide because in fact m is anyway that uniquely defined in eqs. (4,1). By consequence of (ii) force and acceleration are co-aligned at the first order only. The proportionality factor k_G has physical dimensions l^3t^{-2} ; multiplying and dividing the first term at right hand side by a unit mass m'' and noting that $m''m$ can be equivalently rewritten as $m'm''$ because m is arbitrary like m' and m'' , the physical dimensions of k_G turn into $l^3t^{-2}m^{-1}$ while

$$F = -Gm'm''\Delta x^{-2} + m'm''a_3\Delta x^{-3} + \dots \quad (4,2)$$

In conclusion eqs. (2,1) allow to infer as corollaries the two basic statements of general relativity, the arising of inertial forces in accelerated systems and the equivalence principle.

This result legitimates the attempt to extend the approach hitherto outlined to the general relativity, but requires introducing a further remark that concerns the concept of covariance; this concept has to do with the fact that eqs. (4,1) introduce in fact two forces F_x and F_o in inertial, R , and non-inertial, R_o , reference systems. This early idea introduced by Einstein first in the special relativity and then extended also to the general relativity, aimed to exclude privileged reference systems by postulating the equivalence principle and replacing the concept of gravity force with that of space-time curved by the presence of the mass; Gaussian curvilinear coordinates and tensor calculus are thus necessary to describe the local behavior of a body in a gravity field. This choice allowed on the one side to explain the gedankenexperiment of light beam bending within an accelerated room and on the other side to formulate a covariant theory of universal gravitation through space-time Gaussian coordinates.

Yet the covariance requires a mathematical formalism that generates conflict with the probabilistic basis of the quantum mechanics: the local metric of the space-time is indeed deterministic, obviously the gravity field results physically different from the quantum fields. It makes really difficult to merge such a way of describing the gravitation with the concepts of non-locality and non-reality that characterize the quantum world. In the present model the concept of force appears instead explicitly: without any "ad hoc" hypothesis the Newton law is obtained as approximate limit case, whereas the transformation from an inertial reference system R to a non-inertial reference system R_o correctly describes the arising of an inertial force.

Hence the present theoretical model surely differs in principle from the special and general relativity; yet, being derived from eqs. (2,1), it is consistent with quantum mechanics as concerns the three key requirements of quantization, non-reality, non-locality. Also, the previous discussion exploits a mathematical formalism that despite its extreme simplicity efficiently bypasses in the cases examined the deterministic tensor formalism of special relativity. In the next sub-section 4.1 attention will be paid to the concept of covariancy, not yet explicitly taken into consideration when introducing the special relativity and apparently skipped so far. Actually this happened because, as shown below, the concept of covariancy is already inherent “per se” in the concept of uncertainty once having postulated the complete arbitrariness of size and boundary coordinates of the delocalization ranges.

Let us conclude this introductory discussion rewriting the eqs. (4,1) as $\Delta\dot{p}_x = F = \mu\Delta\ddot{x}$, where

$$\mu = -n\hbar \frac{\Delta\dot{x}}{\Delta x^2 \Delta\ddot{x}}$$

has of course physical dimensions of mass; indeed $\Delta\dot{p}_x$ ensures that effectively μ must somehow be related to the mass of a particle despite it is defined as a function of space delocalization range and its proper time derivatives only.

It is worth noticing that in eq (3,2) the mass was defined regarding the particle as a delocalized corpuscle confined within Δx , here the quantum of uncertainty \hbar introduces the mass μ uniquely through its physical dimension. Also note that μ/\hbar has dimension of a reciprocal diffusion coefficient D , so the differential equation $\Delta\dot{x}/(\Delta x^2 \Delta\ddot{x}) = \mp(Dn)^{-1}$ admits the solution $\Delta x = (L(\xi) + 1) \sqrt{D\tau_o}$, where L is the Lambert function and $\xi = \pm n \exp(\mp n \Delta t / \tau_o)$; the double sign is due to that possibly owned by μ , the integration constants are $-t_o$ defining $\Delta t = t - t_o$ and τ_o . In conclusion we obtain in the same R of eqs. (4,1)

$$F = \pm n^2 \frac{\hbar/\tau_o}{\sqrt{D\tau_o}} \frac{L(\xi)}{(L(\xi) + 1)^3}, \quad \frac{\Delta x}{\Delta x_D} = L(\xi) + 1, \\ \mu = \pm \hbar/D, \quad \xi = \pm n \exp(\mp n \Delta t / \tau_o), \quad (4,3)$$

$$\Delta x_D = \sqrt{D\tau_o}.$$

Note that the ratio $\Delta\dot{x}/\Delta\ddot{x} = \mp(L(\xi) + 1)^2 \tau_o/n$ inferred from the given solution never diverges for $n > 0$; moreover Δx defined by this solution is related to the well known FLRW parameter $q = -\ddot{a}/\dot{a}^2$, where a is the scale factor of the universe. Replacing this latter with Δx thanks to the arbitrariness of Δx_D and Δx itself, one finds that $q = \mp L(\xi)^{-1}$.

The importance of eqs. (4,3) rests on the fact that $\Delta x = \Delta x_D$ for $n = 0$ whereas instead, selecting the lower sign, $\Delta x < \Delta x_D$ for any $n > 0$; the reason of it will be clear in the next section 4.3 dealing with the space-time curvature.

It is worth remarking here the fundamental importance of n : (i) in [9] its integer character was proven decisive to discriminate between reality/locality and non-reality/non-locality of the classical and quantum worlds; (ii) previously small or large values of n were found crucial to describe relativistic or non-relativistic behavior; (iii) here the values $n = 0$ and $n > 0$ appear decisive to discriminate between an unphysical world without eigenvalues and a physical world as we know it. This last point will be further remarked in the next subsection 4.2.

Eventually μ deserves a final comment: μ is a mass defined within Δx uniquely because of its $\Delta\dot{x}$ and $\Delta\ddot{x}$; its sign can be in principle positive or negative depending on that of the former or the latter.

Relate Δx to the size of our universe, which is still expanding so that $\Delta\dot{x} \neq 0$; also, since there is no reason to exclude that the dynamics of the whole universe corresponds to $\Delta\ddot{x} \neq 0$ too, assume in general an expansion rate not necessarily constant.

It follows for instance $\mu < 0$ if the universe expands at increasing rate, i.e. with $\Delta\dot{x} > 0$ and $\Delta\ddot{x} > 0$. Eqs. (4,3) show that a mass is related to non-vanishing Δx and $\Delta\dot{x}$, $\Delta\ddot{x}$. This result appears in fact sensible recalling the dual corpuscle/wave behavior of quantum particles, i.e. imagining the particle as a wave propagating throughout the universe.

It is known that a string of fixed length L vibrates with two nodes L apart, thus with fundamental frequency $\nu_o = v/2L$ and harmonics $\nu_n = n\nu_o = nv/2L$; the propagation velocity of the wave is $v = \nu_n \lambda_n = \sqrt{T/\sigma}$, being T and σ the tension and linear density of the string. If L changes as a function of time while the string is vibrating and the wave propagating, then ν_n and λ_n become themselves functions of time.

Let the length change occur during a time δt ; it is trivial to find $\delta\nu_n/\nu_n = (\dot{v}/v - \dot{L}/L)\delta t$, i.e. the frequency change involves L , \dot{L} and \dot{v} . Put now L equal to the diameter of the universe at a given time, i.e. identify it with Δx ; then propagation rate and frequency of the particle wave clearly change in an expanding universe together with its dynamic delocalization extent.

This therefore means changing the energy $\hbar\delta\nu_n$ of the particle wave, which in turn corresponds to a mass change $\delta m = \hbar\delta\nu_n c^{-2}$. All this agrees with the definition $\mu = \mu(\Delta x, \Delta\dot{x}, \Delta\ddot{x})$ and supports the analogy with the vibrating string. If so the mass μ results related itself to the big-bang energy, early responsible of the expansion. Once again is the uncertainty the key to highlight the origin of μ : likewise as the time change of Δx entails the rising of a force, see eqs. (4,1), correspondingly the time change of the size of the universe changes the delocalization extent of all matter in it contained and thus its internal energy as well.

Two questions arise at this point: has μ so defined something to do with the supposed “dark mass”? If this latter is reasonably due to the dynamics of our universe and if the kind of this dynamics determines itself both space-time curvature and sign of $\pm\mu$, has this sign to do with the fact that

our universe is preferentially made of matter rather than of antimatter? Work is in advanced progress to investigate these points, a few preliminary hints are sketched below.

4.1 Uncertainty and covariacy

In general the laws of classical mechanics are not covariant by transformation from inertial to non-inertial reference systems. Their form depends on the arbitrary choice of the reference system describing the time evolution of local coordinates, velocities and accelerations; this choice is subjectively decided for instance to simplify the formulation of the specific problem of interest.

A typical example is that of a tethered mass m rotating frictionless around an arbitrary axis: no force is active in R where the mass rotates, whereas in R_o solidal with the mass is active the centrifugal force; also, if the constrain restraining the mass to the rotation axis fails, the motion of the mass becomes rectilinear and uniform in R but curved in R_o , where centrifugal and Coriolis forces also appear. Let in general the non-covariacy be due to a local acceleration a_R in R , to which corresponds a combination a_{R_o} of different accelerations in R_o . This dissimilarity, leading to fictitious forces appearing in R_o only, suggested to Einstein the need of a covariant theory of gravitation. Just in this respect however the theoretical frame of the present model needs some comments.

First, the local coordinates are conceptually disregarded since the beginning and systematically eliminated according to the positions (2,2), whence the required non-locality and non-reality of the present model; accordingly the functions of coordinates turn into functions of arbitrary ranges, i.e. in 2D $a_R(x, t) \rightarrow a_R(\Delta x, \Delta \varepsilon, \Delta p, \Delta t, n)$, whereas the same holds for a_{R_o} . So the classical x -components of a_R and a_{R_o} transform anyway into different combinations of the same ranges $\Delta x, \Delta \varepsilon, \Delta p, \Delta t$; the only information is that the local a_R and a_{R_o} become random values within ranges $\Delta a_R = a_R^{(2)} - a_R^{(1)}$ and $\Delta a_{R_o} = a_{R_o}^{(2)} - a_{R_o}^{(1)}$. Yet being these range sizes arbitrary and unpredictable by definition, maybe even equal, is still physically significant now the formal difference between a_R and a_{R_o} ?

Second, eqs. (4,1) introduce explicitly a force component F via $\Delta \dot{p}_x$ consequence of $\Delta \dot{x} \neq 0$; still appears also in the present model the link between force and deformation of the space-time, hitherto intended however as expansion or contraction of a 2D space-time uncertainty range.

Third, the positions (2,2) discriminate non-inertial, R_o , and inertial, R , reference systems; from the arbitrariness of x_o and p_o follows that of \dot{x}_o and \dot{p}_o as well. For instance the previous discussion on the 2D eqs. (4,1) leads directly to Einstein's gedankenexperiment of the accelerated box; in the present model the expected equivalence between gravity field in an inertial reference system, F_x , and inertial force in accelerated frames, F'_o , is indeed obtained simply considering the time dependence of both boundary coordinates of Δx ; with-

out specifying anything, this also entails the equivalence of gravitational and inertial mass. Being all space-time ranges arbitrary, the equivalence principle previously inferred is extensible to any kind of acceleration through a more general, but conceptually identical, 4D transformation from any R to any other R_o ; indeed defining appropriately x_{oj} and their time derivatives \dot{x}_{oj} and \ddot{x}_{oj} times m , with $j = 1, 2, 3$, one could describe in principle also the inertial forces of the example quoted above through the respective p_j, p_{oj} and \dot{p}_j, \dot{p}_{oj} .

The key point of the present discussion is just here: the arbitrariness of both x_j and x_{oj} generalizes the chances of accounting in principle for any a_R and any a_{R_o} . A typical approach of classical physics consists of two steps: to introduce first an appropriate R according which are defined the local coordinates and to examine next the same problem in another R_o via a suitable transformation of these coordinates, whence the necessity of the covariacy. The intuitive considerations just carried out suggest instead that the classical concept of coordinate transformation fails together with that of local coordinates themselves. Imagine an observer able to perceive a range of values only, without definable boundaries and identifiable coordinates amidst; when possibly changing reference system, he could think to the transformation of the whole range only. This is exactly what has been obtained from eqs. (4,1) through the arbitrary time dependence of both x and x_o : the classical physics compels deciding either R or R_o , the quantum uncertainty requires inherently both of them via the two boundary coordinates of space-time ranges. The ambiguity of forces appearing in either of them only becomes in fact completeness of information, paradoxically just thanks to the uncertainty: the classical freedom of deciding "a priori" either kind of reference system, inertial or not, is replaced by the necessary concurrency of both of them simply because each couple of local dynamical variables is replaced by a couple of ranges.

As shown in the 2D eqs. (4,1), in the present model R -like or R_o -like reference systems are not alternative options but complementary features in describing any physical system that involves accelerations. Accordingly eqs. (4,1) have necessarily introduced two forces, F_x and F_o , related to the two standpoints that entail the equivalence principle as a particular case. After switching the concept of local dynamical variables with that of space-time uncertainty, the physical information turns in general into two coexisting perspectives contextually inferred; inertial and non-inertial forces are no longer two unlike or fictitious images of a unique law of nature merely due to different formulations in R or R_o , but, since each one of them requires the other, they generalize the equivalence principle itself. Just this intrinsic link surrogates here the concept of covariacy in eliminating a priori the status of privileged reference system. On the one hand, the chance of observers sitting on accelerated x_o or x excludes by necessity a unique kind of reference system; on the other hand, avoiding fictitious forces appearing in R_o only testifies the ability

of the present approach to incorporate all forces into a unique formulation regardless of their inertial and non-inertial nature.

Instead of bypassing the ambiguity of unlike forces appearing in either reference system only by eliminating the forces, the present model eliminates instead the concept itself of privileged reference system in the most general way possible when describing a physical system, i.e. through the concomitant introduction of both R and R_o . The total arbitrariness of both boundary coordinates of the uncertainty ranges on the one side excludes a hierarchical rank of R or R_o in describing the forces of nature, while affirming instead the complementary nature of their unique physical essence; on the other side it makes this conclusion true in general, regardless of whether x_o or x is related to the origin O of R and to the size of Δx .

4.2 Uncertainty and space-time curvature

The concept of curvature is well known in geometry and in physics; it is expressed differently depending on the kind of reference system. In general relativity the space-time curvature radius is given by $\rho = g^{ik} R_{ik}$, being g^{ik} the contravariant metric tensor and R_{ik} the Ricci tensor. As already emphasized, however, the central issue to be considered here is not the mathematical formalism to describe the curvature but the conceptual basis of the theoretical frame hitherto exposed; the key point is again that the positions (2,2) exclude the chance of exploiting analytical formulae to calculate the local curvature of the space-time. So, once having replaced the concept of space-time with that of space-time uncertainty, the way to describe its possible curvature must be accordingly reviewed. Just at this stage, eqs. (2,1) are exploited to plug also the quantum non-locality and non-reality in the conceptual structure of the space-time, i.e. into the general relativity.

In a previous paper [9] these features of the quantum world were introduced emphasizing that the measurement process perturbs the early position and momentum of the observed particle, assumed initially in an unphysical state not yet related to any number of states and thus to any observable eigenvalue. Owing to the impossibility of knowing the initial state of the particle, the early conjugate dynamical variables were assumed to fall within the respective Δx^{\S} and Δp_x^{\S} ; the notation emphasizes that before the measurement process these ranges are not yet compliant with eqs. (2,1), i.e. they are unrelated. These ranges, perturbed during the measurement process by interaction with the observer, collapse into the respective Δx and Δp_x mutually related according to the eqs. (2,1) and thus able to define eigenvalues of physical observables through n ; this also means that Δx^{\S} and Δp_x^{\S} were mere space uncertainty ranges, whereas after the measurement process only they turn into the respective Δx and Δp_x that take by virtue of eqs. (2,1) the physical meaning of space-time uncertainty ranges of position and momentum. The paper

[9] has explained the reason and the probabilistic character of such a collapse to smaller sized ranges, thanks to which the measurement process creates itself the number of states: the non-reality follows just from the fact that after the measurement process only, the particle leaves its early unphysical state to attain an allowed physical state characterized by the n -th eigenvalue.

This kind of reasoning is now conveyed to describe how and why a particle while passing from an unphysical state to any allowed physical state also curves concurrently the space-time. In this way the basic idea of the general relativity, i.e. the space-time curvature, is conceived itself according the concepts of non-reality and non-locality; the latter also follows once excluding the local coordinates and exploiting the uncertainty ranges of eqs. (2,1) only.

To start the argument, note that the arbitrary boundaries of the range $\Delta x^{\S} = x^{\S} - x_o$ control the actual path traveled by a particle therein delocalized. Let the space reference system be an arbitrary 1D x -axis about which nothing is known; information like flat or curled axis is inessential. Thus the following considerations are not constrained by any particular hypothesis on the kind of possible curvature of the early 1D reference system. Consider first the space range Δx^{\S} alone; changing by an arbitrary amount dx^{\S} the actual distance of x^{\S} from x_o on the x -axis, the size of Δx^{\S} changes as well so that $d\Delta x^{\S}/dx^{\S} = 1$, i.e. $d\Delta x^{\S} = dx^{\S}$. This implicitly means that the range Δx^{\S} overlaps to, i.e. coincides with, the reference x -axis. Thus the delocalization motion of the particle lies by definition between the aforesaid boundary coordinates just on this axis, whatever its actual geometry before the measurement process might be. In principle this reasoning holds for any other uncertainty range corresponding to Δx^{\S} , e.g. the early local energy of a particle delocalized within Δx^{\S} could be a function of its local coordinate along the x -axis; however such a local value of energy is inconsequential, being in fact unobservable in lack of n and thus by definition unphysical.

Consider again the aforesaid 1D space range, yet assuming now that a measurement process is being carried out to infer physical information about the particle; as a consequence of the perturbation induced by the observer, the actual correlation of $\Delta x = x - x_o$ with its conjugate range $\Delta p_x = p_x - p_o$ of allowed momenta introduces n too; now, by virtue of eqs. (2,1), these ranges take the physical meaning of space-time uncertainties and concur to define allowed eigenvalues according to the concept of quantum non-reality. Although Δx is still expressed by two arbitrary coordinates on the x -axis, it is no longer defined by these latter only; rather Δx is defined taking into account also its correlation with Δp_x through n . In other words eqs. (2,1) compel regarding the change of x , whatever it might be, related to that of Δp_x ; this does not contradict the concept of arbitrariness of the ranges so far assumed, as x remains in fact arbitrary like Δp_x itself and unknown like the function $x(\Delta p_x)$ correlating them. Yet, when calculating $d\Delta x/dx$ with the condition $\Delta x \Delta p_x = n\hbar$, we ob-

tain in general $d\Delta x/dx = -(n\hbar)^{-1}\Delta x^2 d\Delta p_x/dx \neq 1$.

To summarize, Δx^{\S} and Δx have not only different sizes but also different physical meaning, i.e. the former is mere precursor of the latter: before the measurement process Δx^{\S} overlapped to the x -axis and had mere space character, the early path length of the particle lay on the reference axis, i.e. $d\Delta x^{\S} = dx^{\S}$; after the measurement process Δx^{\S} shrinks into the new Δx such that in general $d\Delta x \neq dx$, thus no longer coincident with the x -axis and with space-time character. In this way the measurement process triggers the space-time uncertainty, the space-time curvature and the allowed eigenvalues as well.

Let us visualize for clarity why the transition from space to space-time also entails curved Gaussian coordinates as a consequence of the interaction of the particle with the observer. If Δx^{\S} shrinks to Δx , then the early boundary coordinates of the former must somehow approach each other to fit the smaller size of the latter; thus the measurement driven contraction pushes for instance x^{\S} towards a new x closer to x_o along the reference axis previously coinciding with the space range Δx^{\S} and its possible dx^{\S} . So, after shrinking, Δx^{\S} turns into a new bowed space-time range, Δx , forcedly decoupled from the reference x -axis because of its acquired curvature, whence $dx \neq dx^{\S}$ as well. If length of the x -axis and size of the uncertainty range physically allowed to delocalize the particle do no longer coincide, the particle that moves between x_o and x follows actually a bowed path reproducing the new curvature of Δx , no longer that possibly owned by the 1D reference system itself, whence the curvature of the 2D space-time uncertainty range.

This is possible because nothing is known about the actual motion of the particle between the boundary coordinates x_o and x of the reference x -axis; moreover it is also possible to say that the new curvature is due to the presence of a mass in Δx^{\S} , as in lack of a particle to be observed the reasoning on the measurement process would be itself a non-sense.

The last remark suggests correctly that the space-time is actually flat in the absence of matter, as expected from the original Einstein hypothesis, so is seemingly tricky the previous specification that even the early Δx^{\S} could even owe a possible curvature coincident with that of the x -reference axis; this specification, although redundant, was deliberately introduced to reaffirm the impossibility and uselessness of hypotheses on the uncertainty ranges and to avoid confusion between arbitrariness of the uncertainty ranges and Einstein's hypothesis.

Eventually, the probabilistic character of the shrinking of delocalization range, emphasized in [9], guarantees the probabilistic nature of the origin of space-time and its curvature. Indeed all above is strictly related to the time uncertainty: a time range Δt is inevitably necessary to carry out the measurement process during which Δx^{\S} and Δp_x^{\S} collapse into Δx and Δp_x .

As found in the previous section, the correlation of the

range deformation with the time involves change of momentum of the particle within Δp_x , i.e. the rising of a force component as previously explained. This reasoning therefore collects together four concepts: (i) introduces the space-time as a consequence of the measurement process starting from an unphysical state of the particle in a mere space range and in an unrelated momentum range, both not compliant separately with observable eigenvalues; (ii) introduces the non-reality into the space-time curvature, triggered by the measurement process; (iii) links a force field to this curvature by consequence of the measurement process; (iv) introduces the uncertainty into the concepts of flat space and curved space-time: the former is replaced by the idea of an early space uncertainty range where is delocalized the particle coincident with the coordinate axis, whatever its actual geometry might be; the latter is replaced by the idea of early geometry modified by the additional curvature acquired by the new Δx with respect to that possibly owned by the x -axis during their decoupling. Of course just this additional curvature triggered by the measurement process on the particle present in Δx^{\S} is anyway that experimentally measurable.

In conclusion, the measurement process not only generates the quantum eigenvalues of the particle, and thus its observable properties described by their number of allowed states, but also introduces the space-time inherent eqs. (2,1) concurrently with new size and curvature with respect to the precursor space delocalization range. Hence the particle is effectively confined between x_o and x during the time range Δt ; yet, in the 2D feature of the present discussion, it moves outside the reference axis. Actually these conclusions have been already inferred in eqs. (4,3); it is enough to identify Δx^{\S} with the previous Δx_D for $n = 0$ to find all concepts so far described.

Note that the existence of a curved space-time was not explicitly mentioned in section 3, in particular when calculating the orbital and spin angular momenta or hydrogenlike energy in subsection 3.3, simply because it was unnecessary and inconsequential: the eigenvalues do not depend on the properties of the uncertainty ranges, e.g. on their sizes and possible curvature, nor on the random values of local dynamical variables therein defined. To evidence either chance of flat or curved space-time uncertainty, the next sub-section 4.3.2 describes the simulation of a specific physical experiment, the light beam bending in the presence of a gravitational mass, whose outcome effectively depends on the kind of path followed by the particle.

This "operative" aspect of the model is indeed legitimate now; after having introduced the basic requirements of special and general relativity and a possible explanation of the space-time curvature, we are ready to check whether or not some significant outcomes of general relativity can be effectively obtained in the conceptual frame of eqs. (2,1) through the positions (2,2) only. Once again, the essential requirement to merge relativity and quantum mechanics is to regard

the deterministic intervals of the former as the quantum uncertainty ranges of the latter.

4.3 Some outcomes of general relativity

Before proceeding on, it is useful a preliminary remark. Despite the conceptual consistency of eqs. (2,1) with the special relativity, extending an analogous approach to the general relativity seems apparently difficult.

Consider for instance the time dilation and the red shift in the presence of a stationary gravitational potential φ . As it is known, the general relativity achieves the former result putting $dx^1 = dx^2 = dx^3 = 0$ in the interval $-ds^2 = g_{ik}dx^i dx^k$; calculating the proper time in a given point of space as $\tau = c^{-1} \int \sqrt{-g_{00}} dx^0$, the integration yields $\tau = c^{-1} x^0 \sqrt{1 + 2\varphi/c^2}$, i.e. $\tau = c^{-1} x^0 (1 + \varphi/c^2)$.

In an analogous way is calculated the red shift $\Delta\omega = c^{-2} \omega \Delta\varphi$ between two different points of space where exists a gap $\Delta\varphi$ of gravitational potential φ . Are the ranges of eqs. (2,1) alone suitable and enough to find similar results once having discarded the local conjugate variables?

Appears encouraging in this respect the chance of having obtained as corollaries the fundamental statements of special and general relativity. Moreover is also encouraging the fact that some qualitative hints highlight reasonable consequences of eqs. (2,1).

Put $m' = \hbar\omega/c^2$ to describe a system formed by a photon in the gravity field of the mass m ; thus $\Delta\dot{p}_x = F$ of eq (4,1) is now specified as the momentum change of the photon because of the force component F due to m acting on m' . Since the photon moves in the vacuum at constant velocity c there are two possibilities in this respect: the photon changes its wavelength or its propagation direction.

These chances correspond to two relevant outcomes of general relativity, i.e. the red shift and the light beam bending in the presence of a gravity field; the former occurs when the initial propagation direction of the photon coincides with the x -axis along which is defined the force component $\Delta\dot{p}_x$, i.e. radial displacement, the latter when the photon propagates along any different direction. The bending effect is of course closely related to the previous considerations about the actual curvature of the space-time uncertainty range that makes observable the path of the photon; this means that in fact the deflection of the light beam replicates the actual profile of Δx with respect to the x -axis.

Eventually, also the perihelion precession of orbiting bodies is to be expected because of non-Newtonian terms in eq (4,2); it is known indeed that the mere gravitational potential of Newton law allows closed trajectories only [12].

From a qualitative point of view, therefore, it seems that the results of general relativity should be accessible also in the frame of the present theoretical approach. It is necessary however to explain in detail how the way of reasoning early introduced by Einstein is replaced here to extend the previous

results of special relativity. The following subsections aim to show how to discuss the curvature of the space-time uncertainty range and then how to describe time dilation, red shift and light beam bending exploiting uniquely the uncertainty ranges of eqs. (2,1) only, exactly as done at the beginning of section 3.

4.3.1 The time dilation and the red shift

Infer from eqs. (2,1) $\Delta x \Delta p_x / \Delta t = n\hbar / \Delta t$, which also reads $m \Delta x \Delta v_x / \Delta t = n\hbar / \Delta t$. Holds also here the remark introduced about eqs. (4,1), i.e. the particular boundary values of p_o and p_x determining the size of the momentum range $\Delta p_x = p_x - p_o$ are arbitrary, not specifiable in principle and indeed never specified; therefore, since neither p_o nor p_x need being calculated, the actual expression of local momentum is here inessential. So, merely exploiting the physical dimensions of momentum, it is possible to replace Δp_x with $m \Delta v_x$ and write $m \Delta v_x \Delta x / \Delta t = n\hbar / \Delta t$, whatever Δv_x and m might in fact be. Hence, the energy at right hand side can be defined as follows

$$m\varphi_x = -\frac{n\hbar}{\Delta t}, \quad \varphi_x = -\Delta x \frac{\Delta v_x}{\Delta t}, \quad \varphi_x < 0. \quad (4,4)$$

Being the range sizes positive by definition, φ_x has been intentionally introduced in the first equation with the negative sign in order that $m\varphi_x = -\Delta\varepsilon$ correspond to an attractive force component $F = -\Delta\varepsilon/\Delta x$ of the same kind of the Newton force, in agreement with the conceptual frame of relativity. Also, φ_x does not require specifying any velocity because for the following considerations is significant its definition as a function of Δv_x only. This result can be handled in two ways.

In the first way, the first eq. (4,4) is rewritten as follows

$$-\frac{\hbar}{\Delta t} = \varepsilon \frac{\varphi_x}{c^2}, \quad \varepsilon = (m/n)c^2, \quad (4,5)$$

in which case one finds

$$\frac{\Delta t - t_o}{\Delta t} = 1 + \frac{\varphi_x}{c^2}, \quad \frac{\hbar}{\varepsilon} = t_o, \\ \frac{m\varphi_x}{\Delta x} = -m \frac{\Delta v_x}{\Delta t} = -F_N. \quad (4,6)$$

Note that t_o is a proper time of the particle, because it is defined through the energy of this latter. In this case the number n is unessential and could have been omitted: being the mass m arbitrary, m/n is a new mass arbitrary as well. The third result defines φ_x as a function of the expected Newton force component F_N ; hence φ_x corresponds classically to a gravitational potential. The first equation is interesting: it correlates through φ_x the time ranges $\Delta t' = \Delta t - t_o$ and Δt . Note that if $\varphi_x \rightarrow 0$ then $\Delta t \rightarrow \infty$ according to eqs. (4,4) or (4,5), i.e. $\Delta t' \rightarrow \Delta t$; hence the gravitational potential φ_x provides a relativistic correction of Δt , which indeed decreases to $\Delta t'$ for $\varphi_x \neq 0$. Eq. (4,6) is thus just the known

expression $\tau = (x_0/c)(1 + \varphi_x/c^2)$ previously reported once replacing $\tau/(c^{-1}x_0)$ with $\Delta t'/\Delta t$; indeed in the present approach the local quantities are disregarded and replaced by the corresponding ranges of values. The first eq (4,6) shows that time slowing down $\Delta t - t_0$ occurs in the presence of a gravitational potential with respect to Δt pertinent to $\varphi_x = 0$.

The second way to handle eqs. (4,4) consists of considering two different values of φ_x at its right hand side and a particle that climbs the radial gap corresponding to the respective values of gravitational potential with respect to the origin of an arbitrary reference system; moreover, being ε constant by definition because t_0 is fixed, the proper times of the particle t_1 and t_2 define the corresponding time ranges Δt_1 and Δt_2 necessary for the particle to reach the given radial distances. So eqs. (4,5) yield with obvious meaning of symbols

$$-\frac{\hbar/\varepsilon}{\Delta t^{(1)}} = \frac{\varphi_x^{(1)}}{c^2} \quad -\frac{\hbar/\varepsilon}{\Delta t^{(2)}} = \frac{\varphi_x^{(2)}}{c^2}.$$

Hence, putting $\omega = \Delta t^{-1}$, one finds

$$\frac{\omega_1 - \omega_2}{\omega_0} = \frac{\varphi_x^{(2)} - \varphi_x^{(1)}}{c^2}, \quad \omega_0 = \frac{\varepsilon}{\hbar}. \quad (4,7)$$

Here ω_0 is the proper frequency of the free photon with respect to which are calculated ω_1 and ω_2 at the respective radial distances. This expression yields the frequency change between two radial distances as a function of ω_0

$$\Delta\omega = \frac{\Delta\varphi_x}{c^2} \omega_0.$$

Since φ_x is negative, the sign of $\Delta\omega$ is opposite to that of $\Delta\varphi_x$: if $\varphi_x^{(2)}$ is stronger than $\varphi_x^{(1)}$, then $\varphi_x^{(2)} - \varphi_x^{(1)} < 0$, which means that $\omega_2 > \omega_1$. One finds the well known expression of the red shift occurring for decreasing values of gravitational potential. We have inferred two famous result of general relativity through uncertainty ranges only. Now we can effectively regard these results as outcomes of quantum relativity.

4.3.2 The light beam bending

Rewrite eq (4,2) as $F_N \Delta x / (\hbar\omega/c^2) = -Gm/\Delta x$; here F_N is due to the mass m acting along the x direction on a photon having frequency ω and traveling along an arbitrary direction; the notation emphasizes that the photon energy $\hbar\omega/c^2$ replaces the mass of a particle in the gravity field of m . The distance between photon and m is of course included within Δx . Introduce with the help of eq (4,4) the gravitational potential $\varphi_x = -F_N \Delta x / m$, so that $\varphi_x/c^2 = Gm/(c^2 \Delta x)$. Now it is possible to define the beam deflection through φ_x , according to the idea that the beam bending is due just to the gravitational potential; we already know why this effect is to be in fact expected. Of course, having discarded the local coordinates, the reasoning of Einstein cannot be followed here; yet

since $\delta\phi = \delta\phi(\varphi_x)$, with notation that emphasizes the dependence of the bending angle $\delta\phi$ of the photon upon the field φ_x , it is certainly possible to express the former as series development of the latter, i.e. $\delta\phi = \alpha + \beta(\varphi_x/c^2) + \gamma(\varphi_x/c^2)^2 + \dots$; α , β and γ are coefficients to be determined. Clearly $\alpha = 0$ because $\delta\phi = 0$ for $m = 0$, i.e. there is no bending effect; so

$$\delta\phi \approx \frac{Gm\beta}{c^2 \Delta x}, \quad \frac{Gm}{c^2 \Delta x} \approx \frac{-\beta + \sqrt{\beta^2 + 4\gamma\delta\phi}}{2\gamma}. \quad (4,8)$$

The former expression is simpler but more approximate than the latter, because it account for one term of the series development of $\delta\phi(\varphi_x)$ only; the latter calculates instead φ_x as a function of $\delta\phi$ at the second order approximation for reasons that will appear below. Consider first the former expression and note that even in lack of local coordinates the deflection can be expressed as the angle between the tangents to the actual photon path at two arbitrary ordinates y_- and y_+ along its way: i.e., whatever the path of the photon might be, we can figure m somewhere on the x -axis and the photon coming from $-\infty$, crossing somewhere the x axis at any distance within Δx from m and then continuing a bent trajectory towards $+\infty$. Let the abscissas of the arbitrary points y_- and y_+ on the x -axis be at distances Δx_- and Δx_+ from m ; the tangents to these points cross somewhere and define thus an angle $\delta\phi'$. The sought total deflection $\delta\phi$ of the photon corresponds thus to the asymptotic tangents for y_- and y_+ tending to $-\infty$ and ∞ . Note now that the same reasoning holds also for a reversed path, i.e. for the photon coming from infinity and traveling towards minus infinity; the intrinsic uncertainty affecting these indistinguishable and identically allowed chances suggests therefore a boundary condition to calculate the change of photon momentum h/λ during its gravitational interaction with the mass. The impossibility of distinguishing either chance requires defining the total momentum range of the photon as $\Delta p = h/\lambda - (-h/\lambda) = 2h/\lambda$, i.e. $\Delta p = (2/c)\hbar\omega$. Since the momentum change depends on $c/2$, and so also the interaction strength $\Delta p/\Delta t$ corresponding to F_N , it is reasonable to assume that even $\delta\phi$ should depend on $c/2$; so putting $\beta = 4$ in the former expression of $\delta\phi$ and noting that the maximum deflection angle calculated for $y_- \rightarrow -\infty$ and $y_+ \rightarrow +\infty$ corresponds to the minimum distance range Δx , one finds the well known result

$$\delta\phi \approx \frac{4Gm}{c^2 \Delta x_{\min}}.$$

The numerical factor 4 appears thus to be the fingerprint of the quantum uncertainty, whereas the minimum approach distance of the Einstein formula is of course replaced here by its corresponding uncertainty range Δx_{\min} . It is also interesting to consider the second equation (4,8), which can be identically rewritten as follows putting $\gamma = \gamma'\beta$ and again $\beta = 4$ to be consistent with the previous result as a particular case; so

$$\rho = \frac{\sqrt{1 + \gamma'\delta\phi} - 1}{\gamma'}, \quad \rho = \frac{r_{Schw}}{\Delta x_{\min}}, \quad r_{Schw} = \frac{2Gm}{c^2},$$

with the necessary convergence condition of the series that reads $|\gamma' \varphi_x / c^2| < 1$ and requires

$$\frac{\sqrt{1 + \gamma' \delta\phi} - 1}{2} < 1.$$

This condition requires $-\delta\phi^{-1} \leq \gamma' < 8\delta\phi^{-1}$, and therefore $r_{Schw} \delta\phi^{-1} \leq \Delta x_{\min} < 4r_{Schw} \delta\phi^{-1}$. Replace in this result $\delta\phi = \pi$ and consider what happens when a photon approaches m at distances r_{bh} between $\pi^{-1}r_{Schw} < r_{bh} < 4\pi^{-1}r_{Schw}$: (i) the photon arrives from $-\infty$ and makes half a turn around m ; (ii) after this one half turn it reaches a position diametrically opposite to that of the previous step; (iii) at this point the photon is still in the situation of the step (i), i.e. regardless of its provenience it can make a further half a turn, and so on. In other words, once arriving at distances of the order of $2Gm/c^2$ from m the photon starts orbiting without possibility of escaping; in this situation m behaves as a black body. Here the event horizon turns actually into a range of event horizons, i.e. into a shell surrounding m about $\sim 3\pi^{-1}r_{Schw}$ thick where the gravitational trapping is allowed to occur; this result could be reasonably expected because no particle, even the photon, can be exactly localized at some deterministic distance from an assigned point of space-time, i.e. the event horizon is replaced by a range of event horizons. Note however that the reasoning can be repeated also imposing $\delta\phi = 2\pi$ and, more in general, $\delta\phi = 2j\pi$ where j describe the number of turns of the photon around m . In principle the reasoning is the same as before, i.e. after j revolutions required by $\delta\phi$ the photon is allowed to continue again further tours; yet now trivial calculations yield $(j\pi)^{-1}r_{Schw} < r_{bh} < 4(j\pi)^{-1}r_{Schw}$. At increasing j the shell allowing the turns of the photon becomes thinner and thinner while becoming closer and closer to m . As concerns the ideal extrapolation of this result to approach distances $r_{bh} < \pi^{-1}r_{Schw}$ one can guess for $j \rightarrow \infty$ the chance of photons to spiral down and asymptotically fall directly on m without a stable orbiting behavior.

4.3.3 The Kepler problem and the gravitational waves

The problem of perihelion precession of planets is too long to be repeated here even in abbreviated form. It has been fully concerned in a paper preliminarily submitted as preprint [13]. We only note here how this problem is handled in the frame of the present model. It is known that the precession is not explained in the frame of classical mechanics. If the potential energy has the form $-\alpha/r$ the planet follows a closed trajectory; it is necessary a form of potential energy like $\alpha/r + \delta U$ to describe the perihelion precession. The Newton law entails the former kind of potential energy, but does not justifies the correction term δU . In our case, however, we have found the Newton law as a particular case of a more general force containing additional terms, eq (4,2); thanks to these latter, therefore, it is reasonable to expect that the additional potential term enables the perihelion precession to be described.

Also in this case the formula obtained via quantum uncertainty ranges coincides with the early Einstein formula. The same holds for the problem of the gravitational waves, also concerned together with some cosmological considerations in the quoted preprint. Both results compel regarding once again the intervals of relativity as uncertainty ranges.

4.3.4 Preliminary considerations on eqs. (4,3)

This subsection introduces preliminary order of magnitude estimates on the propagation wave corresponding to the mass $\mu = \hbar/D$; the \pm sign is omitted because the following considerations concern the absolute value of μ only.

Consider a wave with two nodes at a diametric distance d_u on a sphere simulating the size of universe; the first harmonic has then wavelength $\lambda_u = 2d_u$. Let the propagation rate v of such a wave be so close to c , as shown below, that for brevity and computational purposes only the following estimates are carried out replacing directly v with c . Guess the quantities that can be inferred from D by means of elementary considerations on its physical dimensions in a reference system R fixed on the center of the whole universe. Calculate D as λ_u times c , i.e. $D = 2d_u c$, and define τ as $\sqrt{D\tau} = d_u/2$, i.e. as the time elapsed for μ to cover the radial distance of the universe; so τ describes the growth of the universe from a size ideally tending to zero at the instant of the big-bang to the current radius $\sqrt{D\tau}$. Since $\lambda_u = 0$ at $\tau = 0$ and $\lambda_u = 2d_u$ at the current time τ , then $d_u = 8c\tau$ and $D = 16c^2\tau$. Moreover, considering that G times mass corresponds to D times velocity, guess that $m_u = 16c^3\tau/G$ introduces the mass m_u to which correspond the rest energy $\varepsilon_u = 16c^5\tau/G$ and rest energy density $\eta_u = 3c^2/(16\pi G\tau^2)$ calculated in the volume $V_u = 4\pi(d_u/2)^3/3$ of the universe. Also, the frequency $\omega_\mu = \xi c^2/D$ of the μ -wave defines the zero point energy

$$\varepsilon_{zp} = \hbar\omega_\mu/2 = \mu' c^2/2 \quad \mu' = \xi\mu$$

of oscillation of μ ; the proportionality constant ξ will be justified below. At right hand side appears the kinetic energy of the corpuscle corresponding to $\hbar\omega_\mu/2$, in agreement with the mere kinetic character of the zero point energy. Note that with trivial manipulations $D = 16c^2\tau$ reads also in both forms

$$\frac{\hbar^2}{2\mu(d_u/2)^2} = \frac{\hbar}{2\tau} \quad \lambda_\mu = d_u/2 = \frac{\hbar}{\mu c} \quad (4,9)$$

The left hand side of the first equation yields ε_{zp} of the μ -corpuscle, also calculable from $\Delta p_{zp}^2/2\mu$ i.e. $\hbar^2/2\mu\Delta x_{zp}^2$ replacing Δx_{zp} with $d_u/2$; this means that the momentum of a free unbounded particle initially equal to an arbitrary value p_1 increases to p_2 after confinement in a range Δx_{zp} , whence the conjugate range $\Delta p_{zp} = p_2 - p_1$. Equating this result to $\mu c^2/2$ one finds the second equation, which shows that the Compton length of the μ -particle is the universe radius. Also $\hbar/2\tau$

must describe a zero point energy; this compels introducing the frequency $\omega_u = 1/\tau$ so that it reads $\hbar\omega_u/2$.

Define now the ratio $\sigma_\mu = \mu D/V_\mu\omega_\mu$ to express the linear density of μ as a function of its characteristic volume V_μ and length $\Delta x_\mu = V_\mu\omega_\mu/D$: since the squared length inherent D concerns by definition a surface crossed by the particle per unit time, Δx_μ lies along the propagation direction of μ . This way of defining $\sigma_\mu = \mu/\Delta x_\mu$ is thus useful to calculate the propagation velocity of the μ -wave exploiting the analogy with the string under tension T ; so $v = \sqrt{T/\sigma_\mu}$ yields $T = \hbar c^2/V_\mu\omega_\mu$, which in fact regards the volume V_μ as a physical property of the mass μ . This expression of T appears reasonable recalling that μ is defined by the ratio $\Delta\dot{x}\Delta\ddot{x}^{-1}\Delta x^{-2}$ of uncertainty ranges, which supports the idea of calculating its mass linear density within the space-time uncertainty range Δx_μ that defines σ_μ through V_μ . Consider that also the ratio v^2/G has the dimension of mass/length; replacing again v with c we obtain $c^2 = TG/c^2$, i.e. the tension of the string corresponds to a value of F of eqs. (4,3) of the order of the Planck force acting on μ ; so, comparing with the previous expression of T , one infers $V_\mu \approx \hbar G/\omega_\mu c^2$, i.e. $V_\mu \approx \hbar DG/c^4$. Thus V_μ has a real physical identity defined by the fundamental constants of nature and specified to the present problem by ω_μ^{-1} .

Before commenting this point, let us show that the actual propagation velocity of the μ -wave is very close to c . Exploit the wave and corpuscle formulae of the momentum of μ putting $h/\lambda_u = \mu v/\sqrt{1-(v/c)^2}$ i.e. $2\pi\sqrt{1-(v/c)^2} = (v/c)$; then $v \approx 0.99c$ justifies the expressions inferred above, whereas $\varepsilon_\mu = \mu c^2/\sqrt{1-(v/c)^2}$ is about 6.4 times the rest value μc^2 . Call ξ this kinetic correction factor. In principle all expressions where appears explicitly μ still hold, replacing however this latter with $\mu' = \xi\mu$ as done before; it explains why ω_μ has been defined just via ξ . This is also true for $\varepsilon'_\mu = \mu' c^2$, for $\varepsilon'_{zp} = \varepsilon_{zp}(\mu')$ and for the effective Compton length λ'_μ , which result therefore slightly smaller than $d_u/2$ because it is the Lorentz contraction of the proper length λ_μ , but not for ω_u , whose value is fixed by τ and d_u . Indeed at this point is intuitive to regard τ as a time parameter as a function of which are calculated all quantities hitherto introduced.

Before considering this problem let us introduce the particular value of τ equal to the estimated age of our universe, commonly acknowledged as about 4×10^{17} s; this yields the following today's time figures:

$$\begin{aligned} d_u &= 9.6 \times 10^{26} \text{m}, & m_u &= 2.6 \times 10^{54} \text{kg}, \\ \omega_u &= 2.5 \times 10^{-18} \text{s}^{-1}, & \varepsilon_u &= 2.3 \times 10^{71} \text{J}, \\ \eta_u &= 5.0 \times 10^{-10} \text{Jm}^{-3}, & \hbar\omega_u/2 &= 1.3 \times 10^{-52} \text{J}, \end{aligned}$$

and also

$$\begin{aligned} D &= 5.8 \times 10^{35} \text{m}^2 \text{s}^{-1}, & \omega_\mu &= 9.9 \times 10^{-19} \text{s}^{-1}, \\ \mu &= 1.8 \cdot 10^{-70} \text{kg}, & \mu' &= 1.2 \times 10^{-69} \text{kg}, \end{aligned}$$

$$\varepsilon'_\mu \approx 1.0 \times 10^{-52} \text{J}, \quad \hbar\omega_\mu/2 = 5.2 \times 10^{-53} \text{J}.$$

It is interesting the fact that the results split into two groups of values: the quantities with the subscript u do not contain explicitly μ and are in fact unrelated to D , ω_μ and ε_μ . Are easily recognized the diameter d_u and the mass m_u of matter in the universe, which support the idea that just the dynamics of the universe, i.e. $\Delta\dot{x}$ and $\Delta\ddot{x}$, concur together with its size, i.e. Δx , to the mass in it present.

This was indeed the main aim of these estimates. The average rest mass density m_u/V_u is about $5.6 \times 10^{-27} \text{Kg/m}^3$. Is certainly underestimated the actual energy ε_u , here calculated without the kinetic Lorentz factor taking into account the dynamic behavior of m_u , i.e. the average velocity of the masses in the universe; ε_u and thus η_u are expected slightly greater than the quoted values. However this correction factor can be neglected for the present purposes because it would be of the order of a few % only at the ordinary speed with which moves the matter. The order of magnitude of the energy density η_u , of interest here, is close to that expected for the average vacuum energy density η_{vac} ; it suggests $\eta_u = \eta_{vac}$, i.e. the idea that matter and vacuum are a system at or near to the dynamic equilibrium based on creation and annihilation of virtual particles and antiparticles. This way of linking the energy densities of μ and matter/vacuum emphasizes that the dynamic of the universe, regarded as a whole system, concerns necessarily its total size and life time; this clearly appears in eqs. (4,9) and is not surprising, since μ is consequence itself of the space-time evolution $\Delta\dot{x}\Delta\ddot{x}^{-1}\Delta x^{-2}$ of the universe.

Note now the large gap between the values of μ and m_u : this is because the former is explicit function of D , the latter does not although inferred in the frame of the same reasoning. Despite the different values and analytical form that reveal their different physical nature, a conceptual link is therefore to be expected between them. Let the characteristic volume V_μ be such that $\varepsilon'_{zp}/V_\mu = \eta_{vac} = \eta_u$, which requires $V_\mu = 8\pi G\tau^2\mu'/3$. This means that the universe evolves keeping the average energy density due to the ordinary matter, η_u , in equilibrium with that of the vacuum, η_{vac} , in turn triggered by the zero point energy density of μ' delocalized in it: in this way both η_{vac} and η_u result related to the early big-bang energy and subsequent dynamics of the universe described by μ . To verify this idea, get some numbers: $V_\mu = 8\pi G\tau^2\mu'/3$ results about $1.0 \times 10^{-43} \text{m}^3$, whereas $V_\mu = \hbar G/\omega_\mu c^2$ yields the reasonably similar value $7.9 \times 10^{-44} \text{m}^3$. Moreover there is a further significant way to calculate V_μ . Define the volume $V_\mu = \pi(d_u/2)^2\Delta x_\mu$ and rewrite identically $\Delta x_\mu = \hbar G/Dc^2$, having put T just equal to the Planck force; one finds $V_\mu = \pi\hbar G\tau/c^2$ i.e. $V_\mu = 9.8 \times 10^{-44} \text{m}^3$ that agrees with the previous values although it does not depend on μ and thus on the correction factor ξ . In other words, ξ could have been also calculated in order that ω and μ' fit this last value of V_μ ; of course the result would agree with the relativistic wave/corpuscle behavior of μ .

These outcomes confirm the consistency of the ways to calculate V_μ and the physical meaning of μ' , in particular the considerations about T . Yet the most intriguing result is that the size of V_μ also comes from a very large number, the area of a diametric cross section of the universe, times an extremely small number, the thickness $\Delta x_\mu = 8.6 \times 10^{-97} \text{m}$ used to calculate the linear density σ_μ and thus T . Of course any diametric section is indistinguishable from and thus physically unidentifiable with any other section, otherwise should exist some privileged direction in the universe; so the volume V_μ , whatever its geometrical meaning might be, must be regarded as permeating all universe, in agreement with the concept of delocalization required by eqs. (2,1).

Despite $\mu'c^2/2$ is a very small energy, its corresponding energy density accounts in fact for that of the vacuum because of the tiny value of V_μ . Compare this estimate with that of $m_u c^2$ intuitively regarded in the total volume V_u of the universe: so as V_u is the characteristic volume of ordinary matter, likewise V_μ is the characteristic volume of μ i.e. a sort of effective physical size of this latter. Since $\mu' > \mu$, the first eq (4,9) includes in V_μ an excess of zero point energy with respect to that previously calculated with μ' ; just for this reason indeed $\hbar\omega_u/2 > \hbar\omega'_\mu/2$. The previous expressions of ε'_{zp} account for the actual kinetic mass μ' by replacing the rest mass μ . Yet in the first eq (4,9) this is not possible because τ , once fixed, is consistent with μ and not with μ' . The simplest idea to explain this discrepancy is that actually $\hbar/2\tau$ accounts for two forms of energy: the zero point energy, which can be nothing else but $\xi\mu c^2/2$ previously inferred, plus an extra quantity

$$\delta\varepsilon = \hbar^2\mu^{-1}(d_u/2)^{-2}/2 - \xi\mu c^2/2$$

accounting for the dynamic behavior of both μ -particle and universe. Hence the energy balance per unit volume of universe consists of four terms: η_u , η_{vac} , η_{zp} and $\delta\eta_{zp} = \delta\varepsilon/V_\mu$. The first two terms, equal by hypothesis, are also equal to the third by definition and have been already calculated; $\delta\varepsilon$ amounts to about $7.9 \times 10^{-53} \text{J}$, so that $\delta\eta_{zp} = 8.7 \times 10^{-10} \text{J/m}^3$. Hence $\delta\eta_{zp}$ is about 64% of $\delta\eta_{zp} + \eta_{vac}$ and about 35% of the total energy density $\delta\eta_{zp} + \eta_{vac} + \eta_u + \eta_{zp} = 2.4 \times 10^{-9} \text{J/m}^3$.

The former estimate is particularly interesting because neither η_{vac} nor $\delta\eta_{zp}$ are directly related to the matter present in the universe; rather the picture so far outlined suggests that η_{vac} is related to μ within V_μ randomly delocalized throughout the whole physical size of the universe, whereas the ordinary matter is in turn a local coalescence from the vacuum energy density precursor. This idea explains why $\mu'c^2/V_\mu = 1.1 \times 10^{-9} \text{Jm}^{-3}$ is twice η_u ; actually this result must be intended as $\mu'c^2/V_\mu = \eta_{vac} + \eta_u$. As concerns the negative sign of μ , see eqs. (4,3), note that actually the second eq (4,9) reads $\lambda_\mu = \pm\hbar/\mu c$ and that ξ turns into $-\xi$ replacing v with $-v$; it is easy to realize that this leaves unchanged λ_μ and the quantities that depend on $m\mu'$, e.g. ω_μ and V_μ , while the universe time τ of eq (4,9) changes its sign. Also σ_μ change its

sign, so the tension T must be replaced by $-T$.

The last remark concerns the physical meaning of $\delta\varepsilon$; it is neither vibrational or zero point energy of μ , nor vacuum or matter energy. If so, what then is it? Is it the so called dark energy?

5 Discussion

The discussion of the results starts emphasizing the conceptual path followed in the previous sections to merge relativity and quantum physics via the basic eqs. (2,1). The prerequisites of the present model rest on three outstanding key words: quantization, non-locality, non-reality. Without sharing all three of these features together, the search of a unified theory would be physically unconvincing and intrinsically incomplete. The first result to be noted is that the present model of quantum relativity finds again formulae known since their early Einstein derivation, which indeed agree with the experimental results, although with a physical meaning actually different; instead of deterministic intervals, the relativistic formulae must be regarded as functions of the corresponding uncertainty ranges. On the one side, this coincidence ensures the consistency of the present theoretical model with the experience. On the other side, the sought unification unavoidably compels transferring the acknowledged weirdness of the quantum world to the relativistic phenomena: it requires regarding the intervals and distances likewise the ranges of eqs. (2,1), i.e. as a sort of evanescent entities, undefined and arbitrary, not specified or specifiable by any hypothesis, whose only feature and role rests on their conceptual existence and ability to replace the local dynamical variables, in no way defined and definable too. For instance the invariant interval of special relativity turns into a space-time uncertainty range whose size, whatever it might be, remains effectively unchanged in all inertial reference systems; in other words, this well known concept still holds despite its size is actually indeterminable.

Strictly speaking, it seems understandable that nothing else but an evanescent idea of uncertainty ranges could explain counterintuitive quantum features like the non-reality and non-locality; the former has been described in subsection 4.2 as a consequence of the measurement driven compliance of the eigenvalues with eqs. (2,1), the latter has been related in [9] to the elusiveness of concepts like local distances that hide the ultimate behavior of the matter. The EPR paradox or the dual corpuscle/wave behavior or the actual incompleteness of quantum mechanics testify in fact different appearances of the unique fundamental concept of uncertainty; the approach of sections 3 and 4 is so elementary and straightforward to suggest that the present way of reasoning focuses just on the limited degree of knowledge we can in fact afford, i.e. only on the physical outcome that waives any local information.

Despite this statement represents the most agnostic start-

ing point possible, nevertheless it paradoxically connects quantum theory and relativity in the most profound way expectable: from their basic postulates to their most significant results. In this respect the section 4 shows an alternative conceptual path, less geometrical, towards some relevant outcomes of general relativity: Einstein's way to account for the gravity through the geometrical model of curved space-time is replaced by simple considerations on the uncertainty ranges of four fundamental dynamical variables of eqs. (2,1). In this way the approach is intrinsically adherent to the quantum mechanics, which rests itself on the same equations. For this reason even the general relativity is compliant with the non-locality and non-reality of the quantum world, as it has been sketched in section 3.

This conclusion seems surprising, because usually the relativity aims to describe large objects on a cosmological scale; yet its features inferred in the present paper can be nothing else but a consequence of quantum properties consistent with well known formulae early conceived for other purposes. A more detailed and complete treatment is exposed in the paper [13], including also the gravitational waves and the perihelion precession of the Kepler problem.

The quantization of the gravity field is regarded as the major task in several relativistic models; although this idea is in principle reductive alone, because also the non-reality and non-locality deserve equal attention, examining the present results this way of thinking appears in fact acceptable. Indeed the number of states n accounts not only for the quantization of the results, as it is obvious, but also for the non-locality and non-reality themselves; as highlighted in [9] the reality and locality of the classical world appear for $n \rightarrow \infty$ only, i.e. when n tends to behave like a continuous variable so that the Bell inequality is fulfilled. So it is reasonable to think that the quantization has in effect a hierarchical role predominant on the other quantum properties. Yet this actually happens if n is never exactly specified because of its arbitrariness, thus ensuring the invariance of eqs. (2,1); its effectiveness in describing both quantum and relativistic worlds appears due indeed to its lack of specific definition and to its twofold meaning of number of states and quantum number. Just this ambivalence is the further feature that remarks the importance of n ; on the one side it represents an essential outcome of the quantum mechanics, on the other side it assigns its quantum fingerprint to any macroscopic system necessarily characterized by a number of allowed states. Of course the incompleteness of information governing the quantum world compels an analogous limit to the relativity; yet, without accepting this restriction since the beginning into the sought unified model through eqs. (2,1), the elementary considerations of sections 3 and 4 would rise topmost difficulties in formulating correct outcomes. Moreover, typical ideas of quantum mechanics provide a possible explanation of experiments that involve relativistic concepts. An example in this respect has been proposed in the paper [9] as concerns the possibility of a super-

luminal velocity under investigation in a recent experiment carried out with neutrinos and still to be confirmed. A relativistic quantum fluctuation hypothesized in the quoted paper appears compatible with a superluminal velocity transient that, just because of its transitory character, can be justified without violating any standard result of the deterministic formulae of early relativity. Other problems are presently under investigation.

Regardless of the results still in progress, seems however significant "per se" the fact itself that the quantum character of the relativistic formulae widens in principle the descriptive applicability of the standard relativity.

Submitted on March 16, 2012 / Accepted on March 21, 2012

References

1. Einstein A., Podolski B., Rosen N. Can quantum mechanics description of Physical Reality be considered Complete? *Physical Review*, 1935, v. 47, 777–780.
2. Polcinski J. String theory, Cambridge University Press, 1998, Cambridge.
3. Green M.B., Schwarz J.H. and Witten E. Superstring Theory, Cambridge University Press, (1987).
4. Carlip S., Quantum gravity: a progress report. *Reports on Progress in Physics*, 2001, v. 64, p. 885.
5. Becker K, Becker M., Schwarz J. String theory and M-Theory: a modern introduction. Cambridge University Press, Cambridge, 2007.
6. Wess J., Bagger J. Supersymmetry and Supergravity, Princeton University Press, Princeton, 1992.
7. Tosto S. An analysis of states in the phase space: the energy levels of quantum systems. *Il Nuovo Cimento B*, 1996, v. 111(2), 193–215.
8. Tosto S. An analysis of states in the phase space: the diatomic molecules. *Il Nuovo Cimento D*, 1996, v. 18(12), 1363–1394.
9. Tosto S. Spooky action at a distance or action at a spooky distance? *Progress in Physics*, 2012, v. 1, 11–26.
10. Tosto S. An analysis of states in the phase space: uncertainty, entropy and diffusion. *Progress in Physics*, 2011, v. 4, 68–78.
11. Landau L., Lifchits E. Theorie du Champ, MIR, Moscow, 1966.
12. Landau L., Lifchits E. Mécanique, MIR Moscow, 1969.
13. Tosto S. An analysis of states in the phase space: from quantum mechanics to general relativity, arXiv gr-qc/0807.1011.

On a Fractional Quantum Potential

Robert Carroll

University of Illinois, Urbana, IL 61801, USA

Fractional quantum potential is considered in connection to the fractal calculus and the scale relativity.

1 Introduction

For fractals we refer to [1, 2] and for differential equations cf. also [3–7]. The theme of scale relativity as in [8–15] provides a profound development of differential calculus involving fractals (cf. also the work of Agop et al in the journal Chaos, Solitons, and Fractals) and for interaction with fractional calculus we mention [6, 16–19]. There are also connections with the Riemann zeta function which we do not discuss here (see e.g. [20]). Now the recent paper [21] of Kobelev describes a Leibnitz type fractional derivative and one can relate fractional calculus with fractal structures as in [16, 18, 19, 25] for example. On the other hand scale relativity with Hausdorff dimension 2 is intimately related to the Schrödinger equation (SE) and quantum mechanics (QM) (cf. [12]). We show now that if one can write a meaningful Schrödinger equation with Kobelev derivatives (α -derivatives) then there will be a corresponding fractional quantum potential (QP) (see e.g. [4, 6, 18, 19] for a related fractional equation and recall that the classical wave function for the SE has the form $\psi = R \exp(iS/\hbar)$).

Going now to [21] we recall the Riemann-Liouville (RL) type fractional operator (assumed to exist here)

$${}_c D_z^\alpha [f(z)] = \begin{cases} \frac{1}{\Gamma(-\alpha)} \int_c^z (z-\zeta)^{-\alpha-1} f(\zeta) d\zeta \\ c \in \mathbf{R}, \operatorname{Re}(\alpha) < 0 \\ \frac{d^m}{dz^m} {}_c D_z^{\alpha-m} [f(z)] \\ m-1 \leq \Re \alpha < m \end{cases} \quad (1.1)$$

(the latter for $m \in \mathbf{N} = \{1, 2, 3, \dots\}$). For $c = 0$ one writes **(1A)** ${}_0 D_z^\alpha [f(z)] = D_z^\alpha [f(z)]$ as in the classical RL operator of order α (or $-\alpha$). Moreover when $c \rightarrow \infty$ (1.1) may be identified with the familiar Weyl fractional derivative (or integral) of order α (or $-\alpha$). An ordinary derivative corresponds to $\alpha = 1$ with **(1B)** $(d/dz)[f(z)] = D_z^1 [f(z)]$. The binomial Leibnitz rule for derivatives is

$$D_z^1 [f(z)g(z)] = g(z)D_z^1 [f(z)] + f(z)D_z^1 [g(z)] \quad (1.2)$$

whose extension in terms of RL operators D_z^α has the form

$$D_z^\alpha [f(z)g(z)] = \sum_{n=0}^{\infty} \binom{\alpha}{n} D_z^{\alpha-n} [f(z)] D_z^n [g(z)]; \quad (1.3)$$

$$\binom{\alpha}{k} = \frac{\Gamma(\alpha+1)}{\Gamma(\alpha-k+1)\Gamma(k+1)}; \quad \alpha, k \in \mathbf{C}.$$

The infinite sum in (1.3) complicates things and the binomial Leibnitz rule of [21] will simplify things enormously. Thus consider first a monomial z^β so that

$$D_z^\alpha [z^\beta] = \frac{\Gamma(\beta+1)}{\Gamma(\beta-\alpha+1)} z^{\beta-\alpha}; \quad \Re(\alpha) < 0; \quad \Re(\beta) > -1. \quad (1.4)$$

Thus the RL derivative of z^β is the product

$$D_z^\alpha [z^\beta] = C^*(\beta, \alpha) z^{\beta-\alpha}; \quad C^*(\beta, \alpha) = \frac{\Gamma(\beta+1)}{\Gamma(\beta-\alpha)}. \quad (1.5)$$

Now one considers a new definition of a fractional derivative referred to as an α derivative in the form

$$\frac{d_\alpha}{dz} [z^\beta] = d_\alpha [z^\beta] = C(\beta, \alpha) z^{\beta-\alpha}. \quad (1.6)$$

This is required to satisfy the Leibnitz rule (1.2) by definition, given suitable conditions on $C(\beta, \alpha)$. Thus first **(1C)** $z^\beta = f(z)g(z)$ with $f(z) = z^{\beta-\epsilon}$ and $g(z) = z^\epsilon$ for arbitrary ϵ the application of (1.3) implies that

$$\begin{aligned} \frac{d_\alpha}{dz} [z^\beta] &= z^\epsilon \frac{d_\alpha}{dz} z^{\beta-\epsilon} + z^{\beta-\epsilon} \frac{d_\alpha}{dz} z^\epsilon \\ &= z^\epsilon C(\beta-\epsilon, \alpha) z^{\beta-\epsilon-\alpha} + z^{\beta-\epsilon} C(\epsilon, \alpha) z^{\epsilon-\alpha} \\ &= [C(\beta-\epsilon, \alpha) + C(\epsilon, \alpha)] z^{\beta-\alpha}. \end{aligned} \quad (1.7)$$

Comparison of (1.6) and (1.7) yields **(1D)** $C(\beta-\epsilon, \alpha) + C(\epsilon, \alpha) = C(\beta, \alpha)$. To guarantee (1.2) this must be satisfied for any β, ϵ, α . Thus **(1D)** is the basic functional equation and its solution is **(1E)** $C(\beta, \alpha) = A(\alpha)\beta$. Thus for the validity of the Leibnitz rule the α -derivative must be of the form

$$d_\alpha [z^\beta] = \frac{d_\alpha}{dz} [z^\beta] = A(\alpha)\beta z^{\beta-\alpha}. \quad (1.8)$$

One notes that $C^*(\beta, \alpha)$ in (1.5) is not of the form **(1E)** and the RL operator D_z^α does not in general possess a Leibnitz rule. One can assume now that $A(\alpha)$ is arbitrary and $A(\alpha) = 1$ is chosen. Consequently for any β

$$\frac{d_\alpha}{dz} z^\beta = \beta z^{\beta-\alpha}; \quad \frac{d_\alpha}{dz} z^\alpha = \alpha; \quad \frac{d_\alpha}{dz} z^0 = 0. \quad (1.9)$$

Now let K denote an algebraically closed field of characteristic 0 with $K[x]$ the corresponding polynomial ring and

$K(x)$ the field of rational functions. Let $F(z)$ have a Laurent series expansion about 0 of the form

$$\begin{aligned} F(z) &= \sum_{-\infty}^{\infty} c_k z^k; \\ F_+(z) &= \sum_0^{\infty} c_k z^k; \\ F_-(z) &= \sum_{-\infty}^{-1} c_k z^k; \quad c_k \in K \end{aligned} \tag{1.10}$$

and generally there is a k_0 such that $c_k = 0$ for $k \leq k_0$. The standard ideas of differentiation hold for $F(z)$ and formal power series form a ring $K[[x]]$ with quotient field $K((x))$ (formal Laurent series). One considers now the union **(1F)** $K \ll x \gg = \cup_1^{\infty} K((x^{1/k}))$. This becomes a field if we set

$$x^{1/1} = x, \quad x^{m/n} = (x^{1/n})^m. \tag{1.11}$$

Then $K \ll x \gg$ is called the field of fractional power series or the field of Puiseux series. If $f \in K \ll x \gg$ has the form **(1G)** $f = \sum_{k_0}^{\infty} c_k x^{m_k/n_k}$ where $c_1 \neq 0$ and $m_k, n_k \in \mathbf{N} = \{1, 2, 3, \dots\}$, $(m_i/n_i) < (m_j/n_j)$ for $i < j$ then the order is **(1H)** $O(f) = m/n$ where $m = m_1$, $n = n_1$ and $f(x) = F(x^{1/n})$. Now given n and z complex we look at functions

$$\begin{aligned} f(z) &= \sum_{-\infty}^{\infty} c_k (z - z_0)^{k/n} = f_+(z) + f_-(z); \\ f_+(z) &= \sum_0^{\infty} c_k (z - z_0)^{k/n}, \\ f_-(z) &= \sum_{-\infty}^{-1} c_k (z - z_0)^{k/n}; \quad c_k = 0 \quad (k \leq k_0) \end{aligned} \tag{1.12}$$

(cf. [21] for more algebraic information - there are some misprints).

One considers next the α -derivative for a basis **(1I)** $\alpha = m/n$; $0 < m < n$; $m, n \in \mathbf{N} = \{1, 2, 3, \dots\}$. The α -derivative of a Puiseux function of order $O(f) = 1/n$ is again a Puiseux function of order $(1 - m)/n$. For $\alpha = 1/n$ we have

$$f_+ = \sum_0^{\infty} c_k z^{k/n} = \sum_0^{\infty} c_k z^{\beta}; \quad \beta = \beta(k) = \frac{k}{n} \tag{1.13}$$

leading to

$$\frac{d_{\alpha}}{dz} f_+(z) = \sum_1^{\infty} \alpha \beta c_k z^{(k-1)/n} = \sum_0^{\infty} c_{p+1} \alpha \beta z^{p/n}; \tag{1.14}$$

$$\begin{aligned} \frac{d_{\alpha}}{dz} f_-(z) &= \sum_{-\infty}^{-1} c_k \alpha \beta z^{(k-1)/n} = \sum_{-\infty}^{-2} c_{p+1} \alpha \beta z^{p/n} \\ &= \sum_{-\infty}^{-1} \hat{c}_p z^{p/n}; \quad \hat{c}_{-1} = 0. \end{aligned}$$

Similar calculations hold for $\alpha = m/n$ (there are numerous typos and errors in indexing in [21] which we don't mention further). The crucial property however is the Leibnitz rule

$$\frac{d_{\alpha}}{dz} (fg) = g \frac{d_{\alpha}}{dz} f + f \frac{d_{\alpha}}{dz} g; \quad (d_{\alpha} \sim \frac{d_{\alpha}}{dz}) \tag{1.15}$$

which is proved via arguments with Puiseux functions. This leads to the important chain rule

$$\frac{d_{\alpha}}{dz} F(g_i(z)) = \sum \frac{\partial F}{\partial g_k} \frac{d_{\alpha}}{dz} g_k(z). \tag{1.16}$$

Further calculation yields (again via use of Puiseux functions)

$$\frac{d_{\alpha}^m}{dz^m} \left[\frac{d_{\alpha}^{\ell}}{dz^{\ell}} f \right] = \frac{d_{\alpha}^{\ell}}{dz^{\ell}} \left[\frac{d_{\alpha}^m}{dz^m} f \right], \tag{1.17}$$

$$\int f(z) d_{\alpha} z = \sum_0^{\infty} \int z^{\beta} d_{\alpha} z; \quad \int z^{\beta} d_{\alpha} z = \frac{z^{\beta+\alpha}}{\beta+\alpha}, \tag{1.18}$$

$$\frac{d_{\alpha}}{dz} \int f(z) d_{\alpha} z = f(z) = \int \frac{d_{\alpha}}{dz} d_{\alpha} z, \tag{1.19}$$

where $d_{\alpha} z$ here is an integration symbol here).

The α -exponent is defined as

$$\begin{aligned} E_{\alpha}(z) &= \sum_0^{\infty} \frac{(z^{\alpha}/\alpha)^k}{\Gamma(\alpha+1)} = \exp\left(\frac{z^{\alpha}}{\alpha}\right); \\ E_1(z) &= e^z; \quad E_{\alpha}(0) = 1 \quad (0 < \alpha, 1). \end{aligned} \tag{1.20}$$

The definition is motivated by the fact that $E_{\alpha}(z)$ satisfies the α -differential equation **(1J)** $(d_{\alpha}/dz)E_{\alpha}(z) = E_{\alpha}(z)$ with $E_{\alpha}(0) = 1$. This is proved by term to term differentiation of (1.20). It is worth mentioning that $E_{\alpha}(z)$ does not possess the semigroup property **(1K)** $E_{\alpha}(z_1 + z_2) \neq E_{\alpha}(z_1)E_{\alpha}(z_2)$.

2 Fractals and fractional calculus

For relations between fractals and fractional calculus we refer to [16, 18, 19, 24, 25, 27, 28]. In [16] for example one assumes time and space scale isotropically and writes $[x^{\mu}] = -1$ for $\mu = 0, 1, \dots, D - 1$ and the standard measure is replaced by **(2A)** $d^D x \rightarrow d\rho(x)$ with $[\rho] = -D\alpha \neq -D$ (note [] denotes the engineering dimension in momentum units). Here $0 < \alpha < 1$ is a parameter related to the operational definition of Hausdorff dimension which determines the scaling of a Euclidean volume (or mass distribution) of characteristic size R (i.e. $V(R) \propto R^{d_H}$). Taking $\rho \propto d(r^{D\alpha})$ one has **(2B)** $V(R) \propto \int d\rho_{Euclid}(r) = \propto \int_0^R dr r^{D\alpha-1} \propto R^{D\alpha}$, showing that $\alpha = d_H/D$. In general as cited in [16] the Hausdorff dimension of a random process (Brownian motion) described by a fractional differintegral is proportional to the order α of the differintegral. The same relation holds for deterministic fractals and in general the fractional differintegration of a curve

changes its Hausdorff dimension as $d_H \rightarrow d_H + \alpha$. Moreover integrals on “net fractals” can be approximated by the left sided RL fractional of a function $L(t)$ via

$$\int_0^{\bar{t}} d\rho(t)L(t) \propto {}_0I_{\bar{t}}^\alpha L(t) = \frac{1}{\Gamma(\alpha)} \int_0^{\bar{t}} dt(\bar{t}-t)^{\alpha-1}L(t);$$

$$\rho(t) = \frac{\bar{t}^\alpha - (\bar{t}-t)^\alpha}{\Gamma(\alpha+1)},$$
(2.1)

where α is related to the Hausdorff dimension of the set (cf. [24]). Note that a change of variables $t \rightarrow \bar{t}-t$ transforms (2.1) to

$$\frac{1}{\Gamma(\alpha)} \int_0^{\bar{t}} dt t^{\alpha-1} L(\bar{t}-t). \tag{2.2}$$

The RL integral above can be mapped into a Weyl integral for $\bar{t} \rightarrow \infty$. Assuming $\lim_{\bar{t} \rightarrow \infty}$ the limit is formal if the Lagrangian L is not autonomous and one assumes therefore that $\lim_{\bar{t} \rightarrow \infty} L(\bar{t}-t) = L[q(t), \dot{q}(t)]$ (leading to a Stieltjes field theory action). After constructing a “fractional phase space” this analogy confirms the interpretation of the order of the fractional integral as the Hausdorff dimension of the underlying fractal (cf. [18]).

Now for the SE we go to [4, 6, 18, 19]. Thus from [4] (1009.5533) one looks at a Hamiltonian operator

$$H_\alpha(p, r) = D_\alpha |p|^\alpha + V(r) \quad (1 < \alpha \leq 2). \tag{2.3}$$

When $\alpha = 2$ one has $D_2 = 1/2m$ which gives the standard Hamiltonian operator $(2C) \hat{H}(\hat{p}, \hat{r}) = (1/2m)\hat{p}^2 + \hat{V}(\hat{r})$. Thus the fractional QM (FQM) based on the Levy path integral generalizes the standard QM based on the Feynman integral for example. This means that the path integral based on Levy trajectories leads to the fractional SE. For Levy index $\alpha = 2$ the Levy motion becomes Brownian motion so that FQM is well founded. Then via (2.2) one obtains a fractional SE (GSE) in the form

$$i\hbar\partial_t\psi = D_\alpha(-\hbar^2\Delta)^{\alpha/2}\psi + V(r)\psi \quad (1 < \alpha \leq 2) \tag{2.4}$$

with 3D generalization of the fractional quantum Riesz derivative $(-\hbar^2\Delta)^{\alpha/2}$ introduced via

$$(-\hbar^2\Delta)^{\alpha/2}\psi(r, t) = \frac{1}{(2\pi\hbar)^3} \int d^3p e^{\frac{ipr}{\hbar}} |p|^\alpha \phi(p, t) \tag{2.5}$$

where ϕ and ψ are Fourier transforms. The 1D FSE has the form

$$i\hbar\partial_t\psi(x, t) = -D_\alpha(\hbar\nabla)^\alpha\psi + V\psi \quad (1 < \alpha \leq 2). \tag{2.6}$$

The quantum Riesz fractional derivative is defined via

$$(\hbar\nabla)^\alpha\psi(x, t) = -\frac{1}{2p i \hbar} \int_{-\infty}^{\infty} dp e^{\frac{ipx}{\hbar}} |p|^\alpha \phi(p, t) \tag{2.7}$$

where

$$\phi(p, t) = \int_{-\infty}^{\infty} dx e^{\frac{-ipx}{\hbar}} \psi(x, t) \tag{2.8}$$

with the standard inverse. Evidently (2.6) can be written in operator form as $(2D) i\hbar\partial_t\psi = H_\alpha\psi$; $H_\alpha = -D_\alpha(\hbar\nabla)^\alpha + V(x)$

In [6] (0510099) a different approach is used involving the Caputo derivatives (where ${}_c^+D(x)k = 0$ for $k = constant$). Here for $(2E) f(kx) = \sum_0^\infty a_n(kx)^{n\alpha}$ one writes $(D \rightarrow \bar{D})$

$${}_c^+f(kx) = k^\alpha \sum_0^\infty a_{n+1} \frac{\Gamma(1+(n+1)\alpha)}{\Gamma(1+n\alpha)} (kx)^{n\alpha}. \tag{2.9}$$

Next to extend the definition to negative reals one writes

$$x \rightarrow \bar{x}(x) = sgn(x)|x|^\alpha; \quad \bar{D}(x) = sgn(x) {}_c^+D(|x|). \tag{2.10}$$

There is a parity transformation Π satisfying $(2F) \Pi\bar{x}(x) = -\bar{x}(x)$ and $\Pi\bar{D}(x) = -\bar{D}(x)$. Then one defines $(2G) f(\bar{x}(kx)) = \sum_0^\infty a_n\bar{x}^n(kx)$ with a well defined derivative

$$\bar{D}f(\bar{x}(kx)) = sgn(k)|k|^\alpha \sum_0^\infty a_{n+1} \frac{\Gamma(1+(n+1)\alpha)}{\Gamma(1+n\alpha)} \bar{x}^n(kx). \tag{2.11}$$

This leads to a Hamiltonian H^α with

$$H^\alpha = -\frac{1}{2}mc^2 \left(\frac{\hbar}{mc}\right)^{2\alpha} \bar{D}^i\bar{D}_i + V(\hat{X}^1, \dots, \hat{X}^i, \dots, \hat{X}^{3N}) \tag{2.12}$$

with a time dependent SE

$$H^\alpha\Psi = \left[-\frac{1}{2}mc^2 \left(\frac{\hbar}{mc}\right)^{2\alpha} \bar{D}^i\bar{D}_i + V(\hat{X}^1, \dots, \hat{X}^i, \dots, \hat{X}^{3N}) \right] \Psi$$

$$= i\hbar\partial_t\Psi. \tag{2.13}$$

3 The SE with α -derivative

Now we look at a 1-D SE with α -derivatives $d_\alpha \sim d_\alpha/dx$ (without motivational physics). We write $d_\alpha x^\beta = \beta x^{\beta-\alpha}$ as in (1.9) and posit a candidate SE in the form

$$i\hbar\partial_t\psi = D_\alpha\hbar^2d_\alpha^2\psi + V(x)\psi. \tag{3.1}$$

In [11, 12] for example (cf. also [29]) one deals with a Schrödinger type equation

$$\mathcal{D}^2\Delta\psi + i\mathcal{D}\partial_t\psi - \frac{\mathcal{W}}{2m}\psi = 0 \tag{3.2}$$

where $\mathcal{D} \sim (\hbar/2m)$ in the quantum situation. Further \mathcal{D} is allowed to have macro values with possible application in biology and cosmology (see Remark 3.1 below).

Consider a possible solution corresponding to $\psi = R \exp(iS/\hbar)$ in the form $(3A) \psi = RE_\alpha(iS/\hbar)$ with E_α as in (1.20). Then one has for $S = S(x, t)$ $(3B) \psi_t = R_t E_\alpha + R \partial_t E_\alpha$ and via (1.15)-(1.16)

$$d_\alpha \left[RE_\alpha \left(\frac{iS}{\hbar} \right) \right] = (d_\alpha R)E_\alpha + RE_\alpha \frac{i}{\hbar} (d_\alpha S); \tag{3.3}$$

$$d_\alpha^2 \left[RE_\alpha \left(\frac{iS}{\hbar} \right) \right] = (d_\alpha^2 R)E_\alpha + 2(d_\alpha R)E_\alpha \frac{i}{\hbar} d_\alpha S + RE_\alpha \left(\frac{i}{\hbar} d_\alpha S \right)^2 + RE_\alpha \frac{i}{\hbar} d_\alpha^2 S; \quad (3.4)$$

$$\begin{aligned} \partial_t E_\alpha(z) &= \partial_t \sum_0^\infty \frac{(z^\alpha/\alpha)^k}{\Gamma(k+1)} = \frac{z_t}{\alpha} \sum_1^\infty \frac{(z^\alpha/\alpha)^k}{\Gamma(k)} = \\ &= \frac{z_t}{\alpha} \sum_0^\infty \frac{(z^\alpha/\alpha)^m}{\Gamma(m+1)} = \frac{z_t}{\alpha} E_\alpha. \end{aligned} \quad (3.5)$$

Then from (3B), (3.4), (3.3), and (3.5) we combine real and imaginary parts in

$$i\hbar \left[R_t E_\alpha + \frac{iS_t}{\alpha\hbar} RE_\alpha \right] = VRE_\alpha + D_\alpha \hbar^2 \left[(d_\alpha^2 R)E_\alpha + 2(d_\alpha R)E_\alpha \frac{i}{\hbar} d_\alpha S - \frac{RS E_\alpha}{\hbar^2} (d_\alpha S)^2 + \frac{iRE_\alpha}{\hbar} d_\alpha^2 S \right] \quad (3.6)$$

leading to

$$R_t E_\alpha = -2D_\alpha d_\alpha R E_\alpha (d_\alpha S) - D_\alpha R E_\alpha d_\alpha^2 S; \quad (3.7)$$

$$-\frac{1}{\alpha} S_t RE_\alpha = VRE_\alpha + D_\alpha \hbar^2 d_\alpha^2 RE_\alpha - RE_\alpha (d_\alpha S)^2.$$

Thus E_α cancels and we have

$$R_t = -2D_\alpha (d_\alpha R) (d_\alpha S) - D_\alpha R d_\alpha^2 S; \quad (3.8)$$

$$-\frac{1}{\alpha} S_t R = VR + D_\alpha \hbar^2 d_\alpha^2 R - R (d_\alpha S)^2.$$

Now recall the classical situation here as (cf. [30, 31])

$$S_t + \frac{S_x^2}{2m} + V - \frac{\hbar^2 R''}{2mR} = 0; \quad \partial_t (R^2) + \frac{1}{m} (R^2 S')' = 0. \quad (3.9)$$

This gives an obvious comparison:

1. Compare $2RR_t + (1/m)(2RR'S' + R^2S'') = 0 \sim 2R_t + (1/m)(2R'S' + RS'') = 0$ with $R_t = -2D_\alpha (d_\alpha R) (d_\alpha S) - D_\alpha R d_\alpha^2 S$
2. Compare $S_t + (S_x^2/2m) + V - \frac{\hbar^2 R''}{2mR} = 0$ with $-\frac{1}{\alpha} S_t = V - \frac{D_\alpha \hbar^2 d_\alpha^2 R}{R} + (d_\alpha S)^2$

which leads to

THEOREM 3.1

The assumption (3.1) for a 1-D α -derivative Schrödinger type equation leads to a fractional quantum potential

$$Q_\alpha = -\frac{D_\alpha \hbar^2 d_\alpha^2 R}{R} \quad (3.10)$$

For the classical case with $d_\alpha R \sim R'$ (i.e. $\alpha = 1$) one has $D_\alpha = 1/2m$ and one imagines more generally that $D_\alpha \hbar^2$ may have macro values. ■

REMARK 3.1

We note that the techniques of scale relativity (cf. [11, 12]) lead to quantum mechanics (QM). In the non-relativistic case

the fractal Hausdorff dimension $d_H = 2$ arises and one can generate the standard quantum potential (QP) directly (cf. also [29]). The QP turns out to be a critical factor in understanding QM (cf. [30–32, 35–37]) while various macro versions of QM have been suggested in biology, cosmology, etc. (cf. [8, 11, 12, 38, 39]). The sign of the QP serves to distinguish diffusion from an equation with a structure forming energy term (namely QM for $D_\alpha = 1/2m$ and fractal paths of Hausdorff dimension 2). The multi-fractal universe of [16,23] can involve fractional calculus with various degrees α (i.e. fractals of differing Hausdorff dimension). We have shown that, given a physical input for (3.1) with the α -derivative of Kobelev ([21]), the accompanying α -QP could be related to structure formation in the related theory. ■

Submitted on March 24, 2012 / Accepted on March 25, 2012

References

1. Falconer K. The geometry of fractal sets. Cambridge Univ. Press, 1985; Fractal geometry. Wiley, 2003.
2. Mandelbrot B. Fractals and chaos. Springer, 2004.
3. Kigami J. Analysis on fractals. Cambridge Univ. Press, 2001.
4. Laskin N. arXiv: quant-ph/0206098; math-ph/1009.5533.
5. Strichartz R. Differential equations on fractals. Princeton Univ. Press, 2006.
6. Herrmann R. arXiv: math-ph/0510099; physics/0805.3434; Fraktionale Infinitesimalrechnung. BoD, Norderstedt, 2008.
7. Kilbas A., Srivastava H., and Trujillo J. Theory and applications of fractional differential equations. North-Holland, 2006.
8. Auffray C. and Nottale L. *Progress in Biophysics and Molecular Biology*, v. 97, 79 and 115.
9. Celerier M. and Nottale L. *Journal of Physics A*, 2004, v. 37, 931; 2006, v. 39, 12565; 2007, v. 40, 14471; arXiv: hep-th/0112213.
10. Celerier M. and Nottale L. arXiv: physics/0911.2488 and 1009.2934.
11. Nottale L. arXiv: physics/0812.0941, 0812.3857, and 0901.1270; *Chaos, Solitons, and Fractals*, 2005, v. 25, 797–803; 1996, v. 7, 877–938; 1999, v. 10, 459; 1998, v. 9, 1035 and 1043; 2001, v. 12, 1577; 2003, v. 16, 539.
12. Nottale L. Fractal space time and microphysics: Towards a theory of scale relativity. World Scientific, 1993; Scale relativity and fractional space-time. Imperial College Press, 2011.
13. Nottale L. and Celerier M. arXiv: quant-ph/0711.2418.
14. Nottale L., Celerier M., and Lehner T. arXiv: quant-ph/0307093; *Journal of Mathematical Physics*, 2006, v. 47, 032203.
15. Nottale L. and Lehner T. arXiv: quant-ph/0610201.
16. Calcagni G. arXiv: hep-th/0912.3142, 1001.0571, 1012.1244, 1106.0295, 1106.5787, and 1107.5041.
17. El-Nabulsi R. and Torres D. arXiv: math-ph/0702099.
18. Tarasov V. arXiv: nlin.CD/0312044, 0602029, 0602096, and 1107.4205; astro-ph/0604491; physics/1107.5749; *International Journal of Mathematics*, 2007, v. 18, 281–299.
19. Tarasov V. and Zaslavsky G. arXiv: physics/0511144.
20. Le Mehaute A., Nivanen L., El Kaabouchi A., and Wang Q. arXiv: cond-mat/0907.4252.
21. Kobelev V. arXiv: math-ph/1202.2714; *Chaos*, 2006, v. 16, 043117.
22. Rocco A. and West B. arXiv: chao-dyn/9810030.
23. Calcagni G., Gielen S., and Oriti D. arXiv: gr-qc/1201.4151.

24. Ren F., Liang J., Wang X., and Qiu W. *Chaos, Solitons, and Fractals*, 2003, v. 16, 101–117.
25. Rocco A. and West B. arXiv: chao-dyn/810030.
26. Schevchenko V. arXiv: hep-ph/0903.0565.
27. Eyink G. *Communications in Mathematical Physics*, 1989, v. 125, 613–636; 1989, v. 126, 85–101.
28. Yang XiaoJun. arXiv: math-ph/1106.3010.
29. Carroll R. Thermodynamics and scale relativity. arXiv: gr-qc/1110.3059.
30. Carroll R. Fluctuations, information, gravity, and the quantum potential. Springer, 2006.
31. Carroll R. On the quantum potential. Arima Publ., 2007.
32. Carroll R. On the emergence theme of physics. World Scientific, 2010.
33. Carroll R. Quantum Potential as Information: A mathematical survey. In: *New trends in quantum information*, Eds. Felloni, Singh, Licata, and Sakaji, Aracne Editrice, 2010, 155–189.
34. Carroll R. arXiv: math-ph/1007.4744; gr-qc/1010.1732. and 1104.0383
35. Frieden B. Physics from Fisher information. Cambridge Univ. Press, 1998; Science from Fisher information. Springer, 2004.
36. Garbaczewski P. arXiv: cond-mat/0703147, 0811.3856, and 0902.3536; quant-ph/0612151, 0805.1536, and 1112.5962.
37. Grössing G. *Entropy*, 2010, v. 12, 1975–2044.
38. Zak M. *International Journal of Theoretical Physics*, 1992, v. 32, 159–190; 1994, v. 33, 2215–2280; *Chaos, Solitons, and Fractals*, 1998, v. 9, 113–1116; 1999, v. 10, 1583–1620; 2000, v. 11, 2325–2390; 2002, v. 13, 39–41; 2007, v. 32, 1154–1167; 2306; *Physics Letters A*, 1989, v. 133, 18–22, 1999, v. 255, 110–118; *Information Sciences*, 2000, v. 128, 199–215; 2000, v. 129, 61–79; 2004, v. 165, 149–169.
39. Zak M. *International Journal of Theoretical Physics*, 1994, v. 33, 1113–1116; 2000, v. 39, 2107–2140; *Chaos, Solitons, and Fractals*, 2002, v. 14, 745–758; 2004, v. 19, 645–666; 2005, v. 26, 1019–1033, 2006, v. 28, 616–626; 2007, v. 32, 1154–1167; 2007, v. 34, 344–352; 2009, v. 41, 1136–1149 and 2306–2312; 2009, v. 42, 306–315; *Foundation of Physics Letters*, 2002, v. 15, 229–243.

A Model Third Order Phase Transition in Fe – Pnictide Superconductors

Chinedu E. Ekuma and Ephraim O. Chukwuocha

Department of Physics, University of Port Harcourt, PMB 053 Choba, Port Harcourt, Rivers, Nigeria
E-mail: panaceamee@yahoo.com

By identifying the orders of phase transition through the analytic continuation of the functional of the free energy of the Ehrenfest theory, we have developed a theory for studying the dependence of the local magnetic moment, M on the Fe – As layer separation in the third order phase transition regime. We derived the Euler – Lagrange equation for studying the dynamics of the local magnetic moment, and tested our model with available experimental data.

1 Introduction

Since the discovery of superconductivity in Fe – based pnictides oxides [1], there has been enormous research activities to understand the origin of their superconductivity. This immense interest in the physics and chemistry communities is reminiscent of the excitement that accompanied the discovery of high – T_c cuprate superconductors in the early 1980s. Normally, in Fe – based superconductors, antiferromagnetic (AFM) order is suppressed by charge (hole) doping but spin interactions still exist [2]. It should be noted that superconductivity can still be induced in the pnictides without charge doping through either isoelectric doping, non-stoichiometry, or by use of non-thermal control parameters such as application of non-hydrostatic pressure. Also it should be noted that the parent compounds of the iron pnictides are metallic, albeit highly dissipative, bad metals [3]. Most striking is the spectroscopy evidence that Fe based superconductors are weakly correlated electronic system [4, 5]. Thus, the origin of the observed superconductivity may not be due to Mott physics. Put differently, for the fact that spin is relevant in Fe pnictide superconductors, they are basically itinerant magnetism suggesting that the Mott – Hubbard physics may be irrelevant in physics of Fe pnictide superconductors. We can thus speculate that the superconductivity observed in Fe pnictides are locally and dynamically spin polarized due to strong Fe spin fluctuations with the itinerant nature of Fe providing the “glue”. Hence, spin-fluctuation mediated through the spin channel may be relevant in understanding the origin and nature of the observed superconductivity in Fe pnictide.

Fe pnictide superconductors have layered structure. The Fe atom layers of these pnictide systems are normally sandwiched by pnictogen, for example, Arsenic (As). Hence, the magnetic moment of Fe depends strongly on the inter-layer distances of Fe-As [6]. The magnetic moment of transition metals also depends on volume [7]. This leads to the so-called lattice anharmonicity.

In quasi 2D layered materials, a state with some rather unexpected properties (new mean field solution) is observed at non-zero [8]. This new mean field property observed in these layered systems cannot be described by the ordinary

phenomenological Ginzburg – Landau theory. Also, the thermodynamic relation $\int_0^{T_c} [\delta C_e(H, T)/T]dT = 0$ which holds for 2^{nd} order phase transition is violated in some materials with Bose – Einstein condensate (BEC)-like phase transition (see for example as in spin glasses [9], ferromagnetic and anti-ferromagnetic spin models with temperature driven transitions [10]). We speculate that the normal Landau theory developed for 2^{nd} order phase transition may not adequately account for the physics of the phase transitions and associated phenomena, for example, magneto-volume effect due to lattice anharmonicity in Fe pnictide superconductors. This motivated us to develop a new Landau-like mean field theory for studying Fe-pnictide superconductors. The theory is based on the Ehrenfest classification of orders of phase transitions [11]. Specifically, we will study the dependence of the local magnetic moment, M on the Fe-As layer separation, z .

2 Theoretical Framework

According to Hilfer [12], rewriting the singular part of the local free energy within a restricted path through the critical point in terms of the finite difference quotient, and analytically continuing in the orders, allows one to classify continuous phase transitions precisely according to their orders. We speculate that there exist phase transition of orders greater than two as there is no known physical reason why such transitions should not exist in nature since they certainly exist in a number of theoretical models like quantum chromodynamics (QCD), lattice field theory and statistical physics [13]. At least, higher order phase transitions (≥ 2) are tenuous at best and their non-detection might have been due to the hasty generalization that all that departs from phase transition of order two can always be explained in terms of field fluctuation [13, 14].

The dependence of the magnetic moment, M on the Fe-As layer separation is completely determined by the functional (the magnetic free energy functional), $F[z, \langle M \rangle]$ where $\langle M \rangle$ is the local magnetic moment. However, F must be invariant under the symmetry group (e.g. Abelian Higg’s model) [15] of the disordered phase in order to minimize the total energy [13]. In general, F is a very complex functional of $\langle M \rangle$. To

make $\langle M \rangle$ to be spatially continuous in equilibrium, in the ordered phase, we essentially for all cases, redefine it. This suggests that F be expressed in terms of a local free energy density, $f[z, \langle M \rangle]$ (the local magnetic free energy) which is a function of the field at the point “ z ”. After coarse graining, in its simplest form [13, 14], F is give (for orders of phase transition > 2) by,

$$F_p(M, z) = \int d^d r |M|^{2(p-2)} \{-a_p |M|^2 + b_p |M|^4 + c_p |\nabla M|^2 + |M|^2 \alpha (z - z_c)^{2(p-2)}\}, \forall p > 2 \quad (1)$$

where p is the order of the phase transition, $a_p = a_0(1 - H/H_c)$, $b_p \gg 1$, z is the Fe-As layer distance (inter-atomic separation), z_c is the critical point, and $\alpha < 0$ (a typical material dependent parameter).

Equation 1 is the model equation we are proposing for studying the dependence of M on the Fe-As inter-atomic separation. For 3^{rd} order phase transition, $p = 3$, Eq. 1 reduces to,

$$F_3(M, z) = \int d^d r |M|^2 \{-a_3 |M|^2 + b_3 |M|^4 + c_3 |\nabla M|^2 + |M|^2 \alpha (z - z_c)^2\} \quad (2)$$

If we neglect the gradient term, and minimize the local magnetic free energy with respect to M , Eq. 2 reduces to

$$M^2 = \frac{2}{3b_3} [a_3 + |\alpha|(z - z_c)^2] \quad (3)$$

which basically leads (i.e., substituting Eq. 3 into 2) to the local free energy

$$\langle f_3 \rangle = \left[\frac{2}{3b_3} (a_3 + |\alpha|(z - z_c)^2) \right]^2 \left\{ \frac{5}{3} |\alpha|(z - z_c)^2 - \frac{1}{3} a_3 \right\}. \quad (4)$$

In the presence of the gradient term to the local magnetic free energy, using variational principle, after scaling, we obtain the Euler – Lagrange equation for M as,

$$\varphi^5 - \varphi^3 [1 - \alpha(z - z_c)^2] - \varphi |\nabla^2 \varphi| = 0. \quad (5)$$

3 Model Application

Using the data of Egami et al. [16], we calculated the magnetic moment, M using our model Eq. 3. The plot of experimentally determined critical temperature against our calculated M (μ_B) are as shown in Fig. 1. Observe that there is strong correlation between T_c and M . Most significantly, our model predicted correctly the range of values of magnetic moment of Fe, in Fe pnictide superconductors. As it is evidence from the plot, in Fe pnictide superconductors. As it is evidence from the plot, the magnetic moment range from 0.59 to $0.73 \mu_B$. The experimentally measured value for the magnetic moment of Fe in LaOFeAs for instance, range from 0.30 to $0.64 \mu_B$ [17, 18].

We speculate that the observed strong correlation between T_c and M stems from the fact that the superconducting critical temperature T_c depends very sensitively on the iron pnictogen (i.e., Fe-As-Fe) bond angle which in turn, depends on

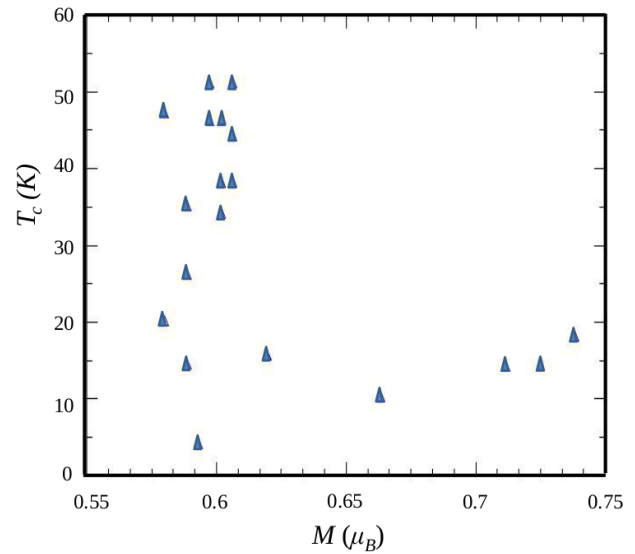

Fig. 1: Color-online. Superconducting experimental critical temperature, T_c from Ref. [16] against the calculated M obtained using Eq. 3 at the critical point.

the Fe-As layer separation [19]. This present observation is in tandem with the understanding that the bonding of the arsenic atoms changed dramatically as a function of magnetic moment [20] and the core-level spectroscopy measurements on CeFeAsO_{0.89}F_{0.11} [21] which showed very rapid spin fluctuation dependent magnetic moment. Since from our model Eq. 3, M is proportional to z (for $a_3 \ll 1$), the observed strong correlation is to be expected. This observation confirms our earlier assertion that spin mediated fluctuations may be the major dominant mediator in the superconductivity of Fe pnictide superconductors. However, electron-phonon coupling through the spin-channel is also to be expected.

Acknowledgment

This work is supported by the Government of Ebonyi State, Federal Republic, Nigeria.

Submitted on March 24, 2012 / Accepted on April 2, 2012

References

1. Kamihara Y., Watanabe T., Hirano, M. and Hosono, H. Iron-based layered superconductor La[O(1-x)F(x)]FeAs ($x = 0.05-0.12$) with $T_c = 26$ K. *Journal of the American Chemical Society*, 2008, v. 130 (11), 3296 – 3297.
2. Haule K., Shim J. H., and Kotliar, G. Correlated Electronic Structure of LaO_{1-x}F_xFeAs. *Physical Review Letters*, 2008, v. 100, 226402.
3. Si Q. and Abrahams A. Strong Correlations and Magnetic Frustration in the High T_c Iron Pnictides. *Physical Review Letters*, 2008, v. 101, 076401.
4. Ren Z.-A., Lu W., Yang J., Yi W., Shen X.-L., Li Z.-C., Che G.-C., Dong X.-L., Sun L.-L., Zhou F. and Zhao Z.-X. Superconductivity at 55 K in Iron-Based F-Doped Layered Quaternary Compound Sm[O_{1-x}F_x]FeAs. *Chinese Physics Letters*, 2008, v. 25, 2215.

5. Yang W.-L., Sorini W.A., Chen C.-C., Moritz B., Lee W.-E., Vernay F., Olalde-Velasco P., Denlinger J.-D., Delley B., Chu F.G., Analytis J.-G., Fisher I.-R., Ren Z.-A., Yang J., Lu W., Zhao Z.-X., van den Brink J., Hussain Z., Shen Z.-X. and Devereaux T.-P. Evidence for weak electronic correlations in iron pnictides. *Physical Review B*, 2009, v. 80, 014508.
6. Yin Z.-P., Lebegue S., Han M.-J., Neal B.P., Savrasov S.-Y. and Pickett W.-E. Electron-Hole Symmetry and Magnetic Coupling in Antiferromagnetic LaFeAsO. *Physical Review Letters*, 2008, v. 101, 047001.
7. Chikazumi S. *Physics of Magnetism*. John Wiley & Sons, New York, NY, USA, 1964.
8. Cronström C. and Noga M. Third-order phase transition and superconductivity in thin films. *Czechoslovak Journal of Physics*, 2001, v. 51 (2), 175 – 184.
9. Stanley H. E. *Introduction to Phase Transition and Critical Phenomena*. Clarendon Press, London, 1971.
10. Camprotrini M., Rossi P. and Vicar E. Large-N phase transition in lattice two-dimensional principal chiral models. *Physical Review D*, 1995, v. 52, 395.
11. Kumar P., Hall D. and Goodrich R. G. Thermodynamics of the Superconducting Phase Transition in $\text{Ba}_{0.6}\text{K}_{0.4}\text{BiO}_3$. *Physical Review Letters*, 1991, v. 82, 4532.
12. Hilfer R. Multiscaling and the classification of continuous phase transitions. *Physical Review Letters*, 1992, v. 68, 190.
13. Ekuma E. C., Asomba G. C. and Okoye C. M. I. Thermodynamics of third order phase transition: A solution to the Euler-Lagrange equations. *Physica B: Condensed Matter*, 2010, v. 405, 2290 – 2293.
14. Ekuma E. C., Asomba G. C. and Okoye C. M. I. Ginzburg–Landau theory for higher order phase transition. *Physica C: Superconductivity*, 2012, v. 472, 1 – 4.
15. Callaway D.J.E. and Carson L.J. Abelian Higgs model: A Monte Carlo study. *Physical Review D*, 1982, v. 25, 531 – 537.
16. Egami T., Fine B. V., Parshall D., Subedi A. and Singh D. J. Spin-Lattice Coupling and Superconductivity in Fe Pnictides. *Advances in Condensed Matter Physics*, 2010, v. 2010, 164916.
17. Ishida K., Nakai Y. and Hosono H. To What Extent Iron-Pnictide New Superconductors Have Been Clarified: A Progress Report. *Journal Physical Society of Japan*, 2009, v. 78, 062001.
18. de la Cruz C., Huang Q., Lynn J. W., Li J., Ratcliff II W., Zarestky J. L., Mook H. A., Chen G. F., Luo J. L., Wang N. L. and Dai P. Magnetic order close to superconductivity in the iron-based layered $\text{LaO}_{1-x}\text{F}_x\text{FeAs}$ systems. *Nature*, 2008, v. 453 (7197), 899 – 902.
19. Lee C.-H., Iyo A., Eisaki H., Kito H., Fernandez-Dia M. T., Ito T., Kihou K., Matsuhata H., Braden M. and Yamada K. Effect of Structural Parameters on Superconductivity in Fluorine-Free LnFeAsO_{1-y} (Ln = La, Nd). *Journal Physical Society of Japan*, 2008, v. 77, 083704.
20. Yildirim T. Strong Coupling of the Fe-Spin State and the As-As Hybridization in Iron-Pnictide Superconductors from First-Principle Calculations. *Physical Review Letters*, 2009, v. 102, 037003.
21. Kreyssig A., Green M. A., Lee Y., Samolyuk G. D., Zajdel P., Lynn J. W., Bud'ko S. L., Torikachvili M. S., Ni N., Nandi S., Leão J. B., Poulton S. J., Argyriou D. N., Harmon B. N., McQueeney R. J., Canfield P. C. and Goldman A. I. Pressure-induced volume-collapsed tetragonal phase of CaFe_2As_2 as seen via neutron scattering *Physical Review B*, 2008, v. 78, 184517

LETTERS TO
PROGRESS IN PHYSICS

LETTERS TO PROGRESS IN PHYSICS**On the Exact Solution Explaining the Accelerate Expanding Universe According to General Relativity**

Dmitri Rabounski

A new method of calculation is applied to the frequency of a photon according to the travelled distance. It consists in solving the scalar geodesic equation (equation of energy) of the photon, and manifests gravitation, non-holonomy, and deformation of space as the intrinsic geometric factors affecting the photon's frequency. The solution obtained in the expanding space of Friedmann's metric manifests the exponential cosmological redshift: its magnitude increases, exponentially, with distance. This explains the accelerate expansion of the Universe registered recently by the astronomers. According to the obtained solution, the redshift reaches the ultimately high value $z = e^{\pi} - 1 = 22.14$ at the event horizon.

During the last three years, commencing in 2009, I published a series of research papers [1–5] wherein I went, step-by-step, in depth of the cosmological redshift problem. I targeted an explanation of the non-linearity of the cosmological redshift law and, hence, the accelerate expansion of the Universe. I suggested that the explanation may be found due to the space-time geometry, i.e. solely with the use of the geometric methods of the General Theory of Relativity.

Naturally, this is the most promising way to proceed in this problem. Consider the following: in 1927, Lemaître's theory [6] already predicted the linear redshift law in an expanding space of Friedmann's metric (a Friedmann universe). As was then shown by Lemaître, this theoretical result matches the linear redshift law registered in distant galaxies*. The anomalously high redshift registered in very distant Ia-type supernovae in the last decade [7–9] manifests the non-linearity of the redshift law. It was then interpreted as the accelerate expansion of our Universe. Thus, once the space-time geometry has already made Lemaître successful in explaining the linear redshift, we should expect a success with the non-linear redshift law when digging more in the theory.

Lemaître deduced the cosmological redshift on the basis of Einstein's field equation. The left-hand side of the equation manifests the space curvature, while the right-hand side describes the substance filling the space. In an expanding space, all objects scatter from each other with the velocity of the space expansion. Lemaître considered the simplest case of deforming spaces — the space of Friedmann's metric. Such a space is free of gravitational fields and rotation, but is curved due to its deformation (expansion or compression). Solving Einstein's equation for Friedmann's metric, Lemaître obtained the curvature radius R of the space and the speed of its

change \dot{R} . Then he calculated the redshift, assuming that it is a result of the Doppler effect on the scattering objects of the expanding Friedmann universe.

Lemaître's method of deduction would remain quite good, except for three drawbacks, namely —

- 1) It works only in deforming spaces, i.e. under the assumption that the cosmological redshift is a result of the Doppler effect in an expanding space. In static (non-deforming) spaces, this method does not work. In other words, herein is not a way to calculate how the frequency of a photon will change with the distance of the photon's travel in the space of a static cosmological metric (which is known to be of many kinds);
- 2) In this old method, the Doppler effect does not follow from the space (space-time) geometry but has the same formula as that of classical physics. Only the speed of change of the curvature radius with time \dot{R} (due to the expansion of space) is used as the velocity of the light source. In other words, the Doppler formula of classical physics is assumed to be the same in an expanding Friedmann universe. This is a very serious simplification, because it is obvious that the Doppler effect should have a formula, which follows from the space geometry (Friedmann's metric in this case);
- 3) This method gives the linear redshift law — a straight line $z = \frac{\dot{R}}{c}$, which “digs” in the wall $\dot{R} = c$. As a result, the predicted cosmological redshift is limited by the numerical value $z_{\max} = 1$. However, we know dozens of much more redshifted galaxies and quasars. In 2011, the highest redshift registered by the astronomers is $z = 10.3$ (the galaxy UDFj-39546284).

So, in his theory, Lemaître calculated the cosmological redshift in a roundabout way: by substituting, into the Doppler formula of classical physics, the speed of change of the curvature radius \dot{R} he obtained his redshift law, i.e., by solving Einstein's equation for Friedmann's metric.

*According to the astronomical observations, spectral lines of distant galaxies and quasars are redshifted as if these objects scatter with the radial velocity $u = H_0 d$, which increases 72 km/sec per each megaparsec of the distance d to the object. $H_0 = 72 \pm 8 \text{ km/sec} \times \text{Mpc} = (2.3 \pm 0.3) \times 10^{-18} \text{ sec}^{-1}$ is known as the Hubble constant. 1 parsec = $3.0857 \times 10^{18} \text{ cm} \approx 3.1 \times 10^{18} \text{ cm}$.

In contrast to Lemaître, I suggested that the cosmological redshift law can be deduced in a more direct and profound way. It is as follows. The generally covariant geodesic equation — the four-dimensional equation of motion of a particle — can be projected onto the time line and the three-dimensional spatial section of an observer. As a result, we obtain the scalar geodesic equation, which is the equation of energy of the particle, and the vectorial geodesic equation (the three-dimensional equation of motion). The in-depth mathematical formalism of the said projection was introduced in 1944 by Zelmanov [10, 11], and is known as the theory of chronometric invariants*. Solving the scalar geodesic equation (equation of energy) of a photon, we shall obtain how the photon's energy and frequency change according to the remoteness of the signal's source to the observer. This is the *frequency shift law*, particular forms of which we can deduce by solving the scalar geodesic equation of a photon in the space of any particular metric.

The same method of deduction may be applied to mass-bearing particles. By solving the scalar geodesic equation for a mass-bearing particle ("stone-like objects"), we shall obtain that the relativistic mass of the object changes according to the remoteness to the observer in the particular space.

First, following this new way of deduction, I showed that the redshift, observed by the astronomers, should be present in a space which rotates at the velocity of light [1, 2]. In this case, the Hubble constant plays a rôle of the frequency of the rotation. The redshift due to the space rotation should be present even if the space is static (non-deforming).

The light-speed rotation is only attributed to the so-called isotropic region of space (home of the trajectories of light). This can be shown by "adapting" the space metric to the isotropic space condition (equality of the metric to zero), which makes a replacement among the components g_{00} and g_{0i} of the fundamental metric tensor $g_{\alpha\beta}$. In Minkowski's space, this replacement means that the isotropic region has a non-diagonal metric, where $g_{00} = 0$, $g_{0i} = 1$, $g_{11} = g_{22} = g_{33} = -1$. Such isotropic metrics were studied in the 1950's by Petrov: see §25 and the others in his *Einstein Spaces* [12]. More insight into this subject is provided in my third paper on the redshift problem [3].

On the other hand, a regular sublight-speed observer shall observe all events according to the components of the fundamental metric tensor $g_{\alpha\beta}$ of his own (non-isotropic) space — home of "solid objects". Therefore, I then continued the research study with the regular metrics, which are not "adapted" to the isotropic space condition.

In two recent papers [4, 5], I solved the scalar geodesic equation for mass-bearing particles and massless particles (photons), in the most studied particular spaces: in the space of Schwarzschild's mass-point metric, in the space of an elec-

trically charged mass-point (the Reissner-Nordström metric), in the rotating space of Gödel's metric (a homogeneous distribution of ideal liquid and physical vacuum), in the space of a sphere of incompressible liquid (Schwarzschild's metric), in the space of a sphere filled with physical vacuum (de Sitter's metric), and in the deforming space of Friedmann's metric (empty or filled with ideal liquid and physical vacuum).

Herein I shall go into the details of just one of the obtained solutions — that in an expanding Friedmann universe, — wherein I obtained the exponential cosmological redshift, thus giving a theoretical explanation to the accelerate expansion of the Universe registered recently by the astronomers.

The other obtained solutions shall be omitted from this presentation. The readers who are curious about them are directly referred to my two recent publications [4, 5].

So, according to Zelmanov's chronometrically invariant formalism [10, 11], any four-dimensional (generally covariant) quantity is presented with its observable projections onto the line of time and the three-dimensional spatial section of an observer. This is as well true about the generally covariant geodesic equation. As Zelmanov obtained, the projected (chronometrically invariant) geodesic equations of a mass-bearing particle, whose relativistic mass is m , are

$$\frac{dm}{d\tau} - \frac{m}{c^2} F_i v^i + \frac{m}{c^2} D_{ik} v^i v^k = 0, \quad (1)$$

$$\frac{d(mv^i)}{d\tau} - m F^i + 2m(D_k^i + A_k^i)v^k + m\Delta_{nk}^i v^n v^k = 0, \quad (2)$$

while the projected geodesic equations of a massless particle-photon, whose relativistic frequency is ω , have the form

$$\frac{d\omega}{d\tau} - \frac{\omega}{c^2} F_i c^i + \frac{\omega}{c^2} D_{ik} c^i c^k = 0, \quad (3)$$

$$\frac{d(\omega c^i)}{d\tau} - \omega F^i + 2\omega(D_k^i + A_k^i)c^k + \omega\Delta_{nk}^i c^n c^k = 0. \quad (4)$$

Here $d\tau = \sqrt{g_{00}} dt - \frac{v_i}{c^2} dx^i$ is the observable time, which depends on the gravitational potential $w = c^2(1 - \sqrt{g_{00}})$ and the linear velocity $v_i = -\frac{c g_{0i}}{\sqrt{g_{00}}}$ of the rotation of space. Four factors affect the particles: the gravitational inertial force F_i , the angular velocity A_{ik} of the rotation of space, the deformation D_{ik} of space, and the Christoffel symbols Δ_{jk}^i (expressing the space non-uniformity). According to the scalar geodesic equation (equation of energy), two factors, F_i and D_{ik} , affect the energy of the particle. They are determined [10, 11] as

$$F_i = \frac{1}{\sqrt{g_{00}}} \left(\frac{\partial w}{\partial x^i} - \frac{\partial v_i}{\partial t} \right), \quad \sqrt{g_{00}} = 1 - \frac{w}{c^2}, \quad (5)$$

$$D_{ik} = \frac{1}{2\sqrt{g_{00}}} \frac{\partial h_{ik}}{\partial t}, \quad D^{ik} = -\frac{1}{2\sqrt{g_{00}}} \frac{\partial h^{ik}}{\partial t}, \quad D = \frac{\partial \ln \sqrt{h}}{\sqrt{g_{00}} \partial t}, \quad (6)$$

where $D = h^{ik} D_{ik}$, while h_{ik} is the chr.inv.-metric tensor

$$h_{ik} = -g_{ik} + \frac{1}{c^2} v_i v_k, \quad h^{ik} = -g^{ik}, \quad h_k^i = \delta_k^i. \quad (7)$$

*The property of chronometric invariance means that the quantity is invariant along the three-dimensional spatial section of the observer.

The geodesic equations of mass-bearing and massless particles have the same form. Only the sublight velocity v^i and the relativistic mass m are used for mass-bearing particles, instead of the observable velocity of light c^i and the frequency ω of the photon. Therefore, they can be solved in the same way to yield similar solutions.

My suggestion is then self-obvious. By solving the scalar geodesic equation of a mass-bearing particle in each of the so-called cosmological metrics, we should obtain how the observed (relativistic) mass of the particle changes according to the distance from the observer in each of these universes. I will further refer to it as the *cosmological mass-defect*. The scalar geodesic equation of a photon should give the formula of the frequency shift of the photon according to the travelled distance (the *cosmological frequency shift*).

Consider the space of Friedmann's metric

$$ds^2 = c^2 dt^2 - R^2 \left[\frac{dr^2}{1 - \kappa r^2} + r^2 (d\theta^2 + \sin^2\theta d\varphi^2) \right], \quad (8)$$

wherein Lemaître [6] deduced the linear redshift law. Here $R = R(t)$ is the curvature radius of the space, while $\kappa = 0, \pm 1$ is the curvature factor. If $\kappa = -1$, the three-dimensional subspace possesses hyperbolic (open) geometry. If $\kappa = 0$, its geometry is flat. If $\kappa = +1$, it has elliptic (closed) geometry.

As is seen from the metric, such a space — a Friedmann universe — is free of ($g_{00} = 1$) and rotation ($g_{0i} = 0$), but is deforming, which reveals the functions $g_{ik} = g_{ik}(t)$. It may expand, compress, or oscillate. Such a space can be empty, or filled with a homogeneous and isotropic distribution of ideal (non-viscous) liquid in common with physical vacuum (Λ -field), or filled with one of the media.

Friedmann's metric is expressed through a "homogeneous" radial coordinate r . This is the regular radial coordinate divided by the curvature radius, whose scales change according to the deforming space. As a result, the homogeneous radial coordinate r does not change its scale with time.

The scalar geodesic equation for a photon travelling along the radial direction in a Friedmann universe takes the form

$$\frac{d\omega}{d\tau} + \frac{\omega}{c^2} D_{11} c^1 c^1 = 0, \quad (9)$$

where c^1 [sec^{-1}] is the solely nonzero component of the observable "homogeneous" velocity of the photon. The square of the velocity is $h_{11} c^1 c^1 = c^2$ [cm^2/sec^2]. We calculate the components of the chr-inv.-metric tensor h_{ik} according to Friedmann's metric. After some algebra, we obtain

$$h_{11} = \frac{R^2}{1 - \kappa r^2}, \quad h_{22} = R^2 r^2, \quad h_{33} = R^2 r^2 \sin^2\theta, \quad (10)$$

$$h = \det ||h_{ik}|| = h_{11} h_{22} h_{33} = \frac{R^6 r^4 \sin^2\theta}{1 - \kappa r^2}, \quad (11)$$

$$h^{11} = \frac{1 - \kappa r^2}{R^2}, \quad h^{22} = \frac{1}{R^2 r^2}, \quad h^{33} = \frac{1}{R^2 r^2 \sin^2\theta}. \quad (12)$$

With these formulae of the components of h_{ik} , we obtain the tensor of the space deformation D_{ik} in a Friedmann universe. According to the definition (6), we obtain

$$D = \frac{3\dot{R}}{R}, \quad D_{11} = \frac{R\dot{R}}{1 - \kappa r^2}, \quad D_1^1 = \frac{\dot{R}}{R}. \quad (13)$$

The curvature radius as a function of time, $R = R(t)$, can be found by assuming a particular type of the space deformation. The trace of the tensor of the space deformation, $D = h^{ik} D_{ik}$, is by definition the speed of relative deformation of the volume. A volume, which is deforming freely, expands or compresses so that its volume undergoes equal relative changes with time

$$D = \text{const}, \quad (14)$$

which, in turn, is a world-constant of the space. This is the primary type of space deformation: I suggest referring to it as the *constant (homotachydioncotic) deformation**.

Consider a constant-deformation (homotachydioncotic) Friedmann universe. With $D = \frac{3\dot{R}}{R}$ according to Friedmann's metric, we have $\frac{\dot{R}}{R} = A = \text{const}$ in this case. We thus arrive at the equation $\frac{1}{R} dR = A dt$, which is $d \ln R = A dt$. Assuming the curvature radius at the moment of time $t = t_0$ to be a_0 , we obtain

$$R = a_0 e^{At}, \quad \dot{R} = a_0 A e^{At}, \quad (15)$$

and, therefore,

$$D = 3A, \quad D_{11} = \frac{a_0^2 A e^{2At}}{1 - \kappa r^2}, \quad D_1^1 = A. \quad (16)$$

Return now to the scalar geodesic equation of a photon in a Friedmann universe, which is formula (9). Because $g_{00} = 1$ and $g_{0i} = 0$ according to Friedmann's metric, we have $d\tau = dt$. Therefore, because $h_{11} c^1 c^1 = c^2$, the scalar geodesic equation transforms into $h_{11} \frac{d\omega}{dt} + \omega D_{11} = 0$. From here we obtain $h_{11} \frac{d\omega}{\omega} = -D_{11} dt$, and, finally, the equation

$$h_{11} d \ln \omega = -D_{11} dt. \quad (17)$$

By substituting h_{11} and D_{11} , we obtain

$$d \ln \omega = -A dt, \quad (18)$$

where $A = \frac{\dot{R}}{R}$ is a world-constant of the Friedmann space.

As is seen, this equation is independent of the curvature factor κ . Therefore, its solution will be common for the hyperbolic ($\kappa = -1$), flat ($\kappa = 0$), and elliptic ($\kappa = +1$) geometry of the Friedmann space.

This equation solves as $\ln \omega = -A t + \ln B$, where B is an integration constant. So forth, we obtain $\omega = B e^{-At}$. We calculate the integration constant B from the condition $\omega = \omega_0$

*I refer to this kind of universe as *homotachydioncotic* (in Greek — ομοταχυδιονγκωτικός). This term originates from *homotachydioncosis* — ομοταχυδιόγκωσις — volume expansion with a constant speed, from όμοις which is the first part of όμοιος (omeos) — the same, ταχύτητα — speed, διόγκωσις — volume expansion, while compression can be considered as negative expansion.

at the initial moment of time $t = t_0 = 0$. We have $B = \omega_0$. Thus, we obtain the final solution $\omega = \omega_0 e^{-At}$ of the scalar geodesic equation. Expanding the world-constant $A = \frac{\dot{R}}{R}$ and the duration of the photon's travel $t = \frac{d}{c}$, we have

$$\omega = \omega_0 e^{-\frac{\dot{R}}{R} \frac{d}{c}}, \quad (19)$$

where $d = ct$ [cm] is the distance to the source emitting the photon. At small distances (and durations) of the photon's travel, the obtained solution takes the linearized form

$$\omega \simeq \omega_0 \left(1 - \frac{\dot{R}}{R} \frac{d}{c} \right). \quad (20)$$

The obtained solution manifests that photons travelling in a constant-deformation (homotachydiastolic) Friedmann universe which expands ($A > 0$) should lose energy and frequency with each mile of the travelled distance. The energy and frequency loss law is exponential (19) at large distances of the photon's travel, and is linear (20) at small distances.

Accordingly, the photon's frequency should be redshifted. The magnitude of the redshift increases with the travelled distance. This is a *cosmological redshift*, in other words.

Let a photon have a wavelength $\lambda_0 = \frac{c}{\omega_0}$ being emitted by a distantly located source, while its frequency registered at the arrival is $\lambda = \frac{c}{\omega}$. Then we obtain the magnitude $z = \frac{\lambda - \lambda_0}{\lambda_0} = \frac{\omega_0 - \omega}{\omega}$ of the redshift in an expanding constant-deformation (homotachydiastolic) Friedmann universe. It is

$$z = e^{\frac{\dot{R}}{R} \frac{d}{c}} - 1, \quad (21)$$

which is an *exponential redshift law*. At small distances of the photon travel, it takes the linearized form

$$z \simeq \frac{\dot{R}}{R} \frac{d}{c}. \quad (22)$$

which manifests a *linear redshift law*.

If such a universe compresses ($A < 0$), this effect changes its sign, thus becoming a *cosmological blueshift*.

Our linearized redshift formula (22) is the same as $z = \frac{\dot{R}}{R} \frac{d}{c}$ obtained by Lemaître [6], the "father" of the theory of an expanding universe. He followed, however, another way of deduction which limited him only to the linear formula. He therefore was confined to believing in the linear redshift law alone.

The ultimately high redshift z_{\max} , which could be registered in our Universe, is calculated by substituting the ultimately large distance into the redshift law. If following Lemaître's theory [6], z_{\max} should follow from the linear redshift law $z = \frac{\dot{R}}{R} \frac{d}{c} = A \frac{d}{c}$. Because $A = \frac{\dot{R}}{R}$ is the world-constant of the Friedmann space, the ultimately large curvature radius R_{\max} is determined by the ultimately high velocity of the space expansion which is the velocity of light $\dot{R}_{\max} = c$. Hence, $R_{\max} = \frac{c}{A}$. The ultimately large distance d_{\max} (the event horizon) is regularly determined from the linear law for scattering galaxies, which is $u = H_0 d$: the scattering velocity u

should reach the velocity of light ($u = c$) at the event horizon ($d = d_{\max}$)*. The law $u = H_0 d$ is known due to galaxies and quasars whose scattering velocities are much lower than the velocity of light. Despite this fact, the empirical linear law $u = H_0 d$ is regularly assumed to be valid upto the event horizon. Thus, they obtain $d_{\max} = \frac{c}{H_0} = (1.3 \pm 0.2) \times 10^{28}$ cm. Then they assume the linear coefficient H_0 of the empirical law of the scattering galaxies to be the world-constant $A = \frac{\dot{R}}{R}$, which follows from the space geometry. As a result, they obtain $d_{\max} = R_{\max}$ and $z_{\max} = H_0 \frac{d_{\max}}{c} = 1$ due to the linear redshift law. How then to explain the dozens of very distant galaxies and quasars, whose redshift is much higher than $z = 1$?

On the other hand, it is obvious that the ultimately high redshift z_{\max} , ensuing from the space (space-time) geometry, should be a result of the laws of relativistic physics. In other words, $z = z_{\max}$ should follow from not a straight line $z = \frac{\dot{R}}{R} \frac{d}{c} = H_0 \frac{d}{c} = \frac{u}{c}$, which digs in the vertical "wall" $u = c$, but from a non-linear relativistic function.

In this case, the Hubble constant H_0 remains a linear coefficient only in the pseudo-linear beginning of the real redshift law arc, wherein the velocities of scattering are small in comparison with the velocity of light. At velocities of scattering close to the velocity of light (close to the event horizon), the Hubble constant H_0 loses the meaning of the linear coefficient and the world-constant A due to the increasing non-linearity of the real redshift law.

Such a non-linear formula has been found in the framework of our theory alluded to here. This is the exponential redshift law (21), which then gives the Lemaître linear redshift law (22) as an approximation at small distances.

We now use the exponential redshift law (21) to calculate the ultimately high redshift z_{\max} , which could be conceivable in an expanding Friedmann space of the constant-deformation type. The event horizon $d = d_{\max}$ is determined by the world-constant $A = \frac{\dot{R}}{R}$ of the space. Thus, the ultimately large curvature radius is $R_{\max} = \frac{c}{A}$, while the distance corresponding to R_{\max} on the hypersurface is $d_{\max} = \pi R_{\max} = \frac{\pi c}{A}$. Suppose now that a photon has arrived from a source, which is located at the event horizon. According to the exponential redshift law (21), the photon's redshift at the arrival should be

$$z_{\max} = e^{\frac{\dot{R}}{R} \frac{d_{\max}}{c}} - 1 = e^{\pi} - 1 = 22.14, \quad (23)$$

which is the ultimately high redshift in such a universe.

The deduced exponential increase of the redshift implies the accelerate expansion of space. This "key prediction" of our theory was surely registered by the astronomers in the last decade: the very distant Ia-type supernovae manifested the increasing non-linearity of the redshift law and, hence, the accelerate expansion of our Universe [7–9].

*The law for scattering galaxies dictates that distant galaxies and quasars scatter with the radial velocity $u = H_0 d$, increasing as 72 km/sec per each megaparsec. The linear coefficient of the law, $H_0 = 72 \pm 8$ km/sec×Mpc = $(2.3 \pm 0.3) \times 10^{-18}$ sec⁻¹, is known as the Hubble constant.

We therefore can conclude that the observed non-linear redshift law and the accelerate expansion of space have been explained in the constant-deformation (homotachydioncotic) Friedmann universe.

The deduced exponential law points out the ultimately high redshift $z_{\max} = 22.14$ for objects located at the event horizon. The highest redshifted objects, registered by the astronomers, are now the galaxies UDFj-39546284 ($z = 10.3$) and UDFy-38135539 ($z = 8.55$). According to our theory, they are still distantly located from the “world end”. We therefore shall expect, with years of further astronomical observation, more “high redshifted surprises” which will approach the upper limit $z_{\max} = 22.14$.

In analogy to massless particles-photons, we can consider the scalar geodesic equation of a mass-bearing particle. In a Friedmann universe this equation takes the form

$$\frac{dm}{d\tau} + \frac{m}{c^2} D_{11} v^l v^l = 0, \quad (24)$$

which, alone, is non-solvable. This is because mass-bearing particles can travel at any sub-light velocity, which is therefore an unknown variable of the equation.

This problem vanishes in a constant-deformation Friedmann universe, by the assumption according to which massive bodies travel not arbitrarily, but are only being carried out with the expanding (or compressing) space. In this particular case, particles travel with the velocity of space deformation, $v = \dot{R}$. Because $v^2 = h_{ik} v^i v^k$, we have $h_{ik} v^i v^k = \dot{R}^2$. Thus, and with $d\tau = dt$ according to Friedmann’s metric, the scalar geodesic equation of mass-bearing particles transforms into $h_{11} \frac{dm}{dt} + \frac{m}{c^2} D_{11} \dot{R}^2 = 0$, i.e. $h_{11} \frac{dm}{m} = -\frac{\dot{R}^2}{c^2} D_{11} dt$. We obtain

$$h_{11} d \ln m = -\frac{\dot{R}^2}{c^2} D_{11} dt. \quad (25)$$

Then, expanding R , \dot{R} (15), and D_{11} (16) according to a constant-deformation space, we obtain the scalar geodesic equation in the form

$$d \ln m = -\frac{a_0^2 A^3 e^{2At}}{c^2} dt, \quad (26)$$

where $A = \frac{\dot{R}}{R} = \text{const}$. It solves as $\ln m = -\frac{a_0^2 A^3}{2c^2} e^{2At} + \ln B$, where the integration constant B can be found from the condition $m = m_0$ at the initial moment of time $t = t_0 = 0$. After some algebra, we obtain the final solution of the scalar geodesic equation. It is the double-exponential function

$$m = m_0 e^{-\frac{a_0^2 A^3}{2c^2} (e^{2At} - 1)}, \quad (27)$$

which, at a small distance to the object, takes the linearized form

$$m \simeq m_0 \left(1 - \frac{a_0^2 A^3 t}{c^2} \right). \quad (28)$$

The obtained solution manifests the *cosmological mass-defect* in a constant-deformation (homotachydiastolic) Friedmann universe: the more distant an object we observe in an expanding universe is, the less should be its observed mass m to its real mass m_0 . Contrarily, the more distant an object we observe in a compressing universe, the heavier should be this object according to observation.

Our Universe seems to be expanding. This is due to the cosmological redshift registered in the distant galaxies and quasars. Therefore, according to the cosmological mass-defect deduced here, we should expect distantly located cosmic objects to be much heavier than we estimate on the basis of astronomical observations. The magnitude of the expected mass-defect should be, according to the obtained solution, in the order of the redshift of the objects.

The cosmological mass-defect complies with the cosmological redshift. Both of these effects are deduced in the same way, by solving the scalar geodesic equation for mass-bearing and massless particles, respectively. One effect cannot be in the absence of the other, because the geodesic equations have the same form. This is a basis of the space (space-time) geometry, in other words. Therefore, once the astronomers register the linear redshift law and its non-linearity in very distant cosmic objects, they should also find the corresponding cosmological mass-defect according to the solution presented here. Once the cosmological mass-defect is discovered, we will be able to say, surely, that our Universe is an expanding Friedmann universe of the constant-deformation (homotachydiastolic) type.

Submitted on January 14, 2012 / Accepted on January 15, 2012

References

1. Rabounski D. Hubble redshift due to the global non-holonomy of space. *The Abraham Zelmanov Journal*, 2009, v. 2, 11–28.
2. Rabounski D. An explanation of Hubble redshift due to the global non-holonomy of space. *Progress in Physics*, 2009, v. 1, L1–L2.
3. Rabounski D. On the speed of rotation of isotropic space: insight into the redshift problem. *The Abraham Zelmanov Journal*, 2009, v. 2, 208–223.
4. Rabounski D. Cosmological mass-defect — a new effect of General Relativity. *The Abraham Zelmanov Journal*, 2011, v. 4, 137–161.
5. Rabounski D. Non-linear cosmological redshift: The exact theory according to General Relativity. *The Abraham Zelmanov Journal*, 2012, v. 5, 3–30.
6. Lemaître G. Un Univers homogène de masse constante et de rayon croissant rendant compte de la vitesse radiale des nébuleuses extragalactiques. *Annales de la Société Scientifique de Bruxelles*, ser. A, 1927, tome 47, 49–59 (published in English, in a substantially shortened form, as: Lemaître G. Expansion of the universe, a homogeneous universe of constant mass and increasing radius accounting for the radial velocity of extra-galactic nebulae. *Monthly Notices of the Royal Astronomical Society*, 1931, v. 91, 483–490).
7. Riess A. G., Filippenko A. V., Challis P., Clocchiatti A., Diercks A., Garnavich P. M., Gilliland R. L., Hogan C. J., Jha S., Kirshner R. P., Leibundgut B., Phillips M. M., Reiss D., Schmidt B. P., Schommer R. A., Smith R. C., Spyromilio J., Stubbs C., Suntzeff N. B.,

- Tony J. Observational evidence from supernovae for an accelerating Universe and a cosmological constant. *The Astronomical Journal*, 1998, v. 116, no. 3, 1009–1038.
8. Perlmutter S., Aldering G., Goldhaber G., Knop R. A., Nugent P., Castro P. G., Deustua S., Fabbro S., Goobar A., Groom D. E., Hook I. M., Kim A. G., Kim M. Y., Lee J. C., Nunes N. J., Pain R., Pennypacker C. R., Quimby R., Lidman C., Ellis R. S., Irwin M., McMahon R. G., Ruiz-Lapuente P., Walton N., Schaefer B., Boyle B. J., Filippenko A. V., Matheson T., Fruchter A. S., Panagia N., Newberg H. J. M., Couch W. J. Measurements of Omega and Lambda from 42 high-redshift supernovae. *The Astrophysical Journal*, 1999, v. 517, no. 2, 565–586.
 9. Leibundgut B. and Sollerman J. A cosmological surprise: the universe accelerates. *Europhysics News*, 2001, v. 32, no. 4, 121–125.
 10. Zelmanov A. L. Chronometric Invariants: On Deformations and the Curvature of Accompanying Space. Translated from the preprint of 1944, American Research Press, Rehoboth (NM), 2006.
 11. Zelmanov A. L. Chronometric invariants and accompanying frames of reference in the General Theory of Relativity. *Soviet Physics Doklady*, 1956, v. 1, 227–230 (translated from *Doklady Akademii Nauk USSR*, 1956, v. 107, no. 6, 815–818).
 12. Petrov A. Z. Einstein Spaces. Pergamon Press, Oxford, 1969 (translated by R. F. Kelleher, edited by J. Woodrow).
-

LETTERS TO PROGRESS IN PHYSICS**Social Aspects of Cold Fusion: 23 Years Later**

Ludwik Kowalski

The field of Cold Fusion, now called Condensed Matter Nuclear Science (CMNS), remains controversial. The original 1989 claim made by M. Fleischmann and S. Pons was that a chemical process in an electrolytic cell could initiate a nuclear reaction—fusion of two deuterium nuclei. More recent CMNS claims, made by experimental scientists, are: emission of charged nuclear projectiles during electrolysis; accumulation of ^4He ; production of radioactive isotopes; and transmutation of elements. In the US, CMNS claims have been evaluated in two Department of Energy (DOE) investigations, in 1989 and 2004, as summarized in this article. These investigations did not lead to any resolution of the controversy. Scientists and administrators are not ideal; competition among them, as among other groups of people, tends to have both positive and negative influences.

1 Introduction

The so-called “scientific methodology”, a set of norms developed to deal with difficulties, especially with mistakes and controversies, is well known. Most scientific mistakes are recognized when new results are discussed with colleagues, or via the peer review process. Occasional errors in published papers are subsequently discovered during replications conducted by other researchers. Scientific results, if valid, wrote Huizenga [1], must be reproducible on demand. “When errors are discovered, acknowledged and corrected, the scientific process moves quickly back on track, usually without either notice or comment in the public press.” The scientific process, in other words, is self-corrective. The purpose of this presentation is to analyze an ongoing controversy about the so-called “cold fusion” (CF). The author of this article, and three other researchers, tried to verify one recent CF claim – emission of alpha particles during electrolysis. The results were negative, as described in [2]. Critical analysis of some CF claims, as illustrated in [3], can enrich nuclear physics courses, even at the undergraduate level.

Why is the CMNS controversy started in 1989 unresolved? Because CF claims are still not reproducible on demand, and because they conflict with accepted theories. A theory, in this context, is not just a hypothesis, or only a logical/mathematical argument. It is a logical structure that is known to agree with a wide range of already verified experimental data. Researchers know the rule–theories guide but experiments decide. But they are very reluctant to abandon accepted theories. To be reluctant means to insist on additional verifications of new experimental results. Referring to such situations, Huizenga wrote: “There are occasionally surprises in science and one must be prepared for them.” Theories are not carved in stone; scientists do not hesitate to modify or reject theories when necessary. Rejecting a highly reproducible experimental result “on theoretical grounds” would not be consistent with scientific metho-

dology. Unlike mathematics, science is based, in the final analysis, on experimental data, not on logical proofs.

2 The Original Claim

It is well known that two hydrogen nuclei can fuse, releasing energy. But this happens only at extremely high temperatures. At ordinary temperatures the probability of the reaction is practically zero, due to the well known coulomb repulsion of positive nuclei. This has been confirmed by reliable experimental data. But two scientists – Steven Jones, a physicist, and Martin Fleischmann, a chemist – independently speculated that this might not always be true. The term CF was introduced by them to identify the claimed fusion of hydrogen nuclei (ionized atoms dissolved in solid metals). The DOE supported Jones’ work long before Fleischmann and his colleague Pons (F&P) applied for similar support. That is why the DOE asked Jones to evaluate the new research proposal. He was later accused (by the administration of Utah University) of stealing the idea of CF from F&P. Trying to establish priority, Utah University organized a press conference (March 23, 1989) at which the discovery of generation of nuclear heat in an electrolytic cell was announced to the world. The released heat was declared to be due to fusion of deuterium nuclei – ionized atoms dissolved in palladium. At that time Jones and his co-workers had already authored numerous peer-reviewed articles [4]. But their claim was not excess heat; it was emission of neutrons.

3 The First DOE Investigation

Most scientists immediately rejected claims conflicting with well-known facts and theories. But many attempts to replicate F&P’s poorly-described experiments were made. Some attempts were successful (unaccounted heat was generated at rates close to one watt), while others were not [5]. That was the beginning of the controversy. Fleischmann and Pons wanted to study the CF phenomenon for another year or so but

were forced to announce the discovery by the university administrators [6]. They had no evidence that the measured heat was due to a nuclear reaction. The only thing they knew was that it could not be attributed to a known chemical reaction.

Suppose their experimental results had been described without any interpretation, and the phenomenon had been named “anomalous electrolysis”. Such a report would not have led to a sensational press conference; it would have been made in the form of an ordinary peer review publication. Only electrochemists would have been aware of the claim; they would have tried to either confirm or refute it. The issue of “how to explain excess heat” would have been addressed later, if the reported phenomenon were confirmed. But that is not what happened. Instead of focusing on experimental data (in the area in which F&P were recognized authorities) most critics focused on the disagreements with the coulomb barrier theory. Interpretational mistakes were quickly recognized and this contributed to the premature skepticism toward their experimental data.

But the significance of CF, if real, was immediately recognized. Some believed that ongoing research on high-temperature fusion, costing billions of dollars, should be stopped to promote research on CF. Others concluded, also prematurely, that such a move would be opposed by “vested interests” of mainstream scientists. Responding to such considerations, the US government quickly ordered a formal investigation. A panel of scientists, named ERAB (Energy Research Advisory Board), and headed by John Huizenga, was formed to investigate CF in 1989. The final report, submitted to the DOE several months later, interfered with the normal development of the field. It should be noted that ERAB scientists investigating the CF claims were not personally involved in replications of experiments. Their report [7], based on visits to several laboratories rather than participation in experiments, can be summarized by the following statements:

Conclusions:

1. There is no evidence that a nuclear process is responsible for excess heat.
2. Lack of experimental reproducibility remains a serious concern.
3. Theoretically predicted fusion products were not found in expected quantities.
4. There is no evidence that CF can be used to produce useful energy.
5. The CF interpretation is not consistent with what is known about hydrogen in metals.
6. The CF interpretation is not consistent with what is known about nuclear phenomena.

Recommendations:

7. We recommend against any extraordinary funding.
8. We recommend modest support for more experiments.

9. We recommend focusing on excess heat and possible errors.
10. We recommend focusing on correlations between fusion products and excess heat.
11. We recommend focusing on the theoretically predicted tritium in electrolytic cells.
12. We recommend focusing on theoretically predicted neutrons.

Note that only one conclusion (item 2) refers to CF experiments. Conclusion 4 is about anticipated practical uses of CF while the remaining four conclusions (1, 3, 5, and 6) are about various aspects of the suggested interpretation of experimental results. Instead of focusing on reality of excess heat critics focused on the fact that the hypothesis was not consistent with what was known about hot nuclear fusion. The same observation can be made about recommendations. Only one of them (item 9) refers to possible errors in experiments. Items 7 and 8 refer to future funding while items 10, 11, and 12 refer to what was expected on the basis of the suggested hot-fusion interpretation. It is clear that the ERAB observations were based mostly on “theoretical grounds,” and not on identified errors in experimental data. Recommendations about future financial support for CF were very important. But they were ignored by the DOE. Support for CF research practically stopped in 1989. Another result of the first DOE investigation was that editors of some scientific journals stopped accepting articles dealing with CF research. Why was the scientific methodology of validation of claims – theories guide but experiments decide – not followed by the DOE-appointed scientists? Why did “rejections on theoretical grounds” prevail?

4 The Second DOE Investigation

The second DOE investigation of CF was announced in March 2004, nearly 15 years after the first one. Links to three online documents related to that investigation – Conference Agenda, Meeting Agenda, and DOE CF Report – can be found in [8]. The six most important scientific questions, based on new experimental claims, were:

- a) Is it true that unexpected protons, tritons, and alpha particles are emitted [9, 10] in some CF experiments?
- b) Is it true that generation of heat, in some CF experiments, is linearly correlated with the accumulation of ^4He and that the rate of generation of excess heat is close to the expected 24 MeV per atom of ^4He [9, 11]?
- c) Is it true that highly unusual isotopic ratios [9, 12] have been observed among the reaction products?
- d) Is it true that radioactive isotopes [9, 13] have been found among reaction products?
- e) Is it true that transmutation of elements [10, 14] has occurred?

- f) Are the ways of validating of claims made by CF researchers (see conference reports presented at [16, 17, 18]) consistent with accepted methodologies in other areas of science?

A positive answer to even one of these questions would be sufficient to justify an official declaration that cold fusion, in light of recent data, should be treated as a legitimate area of research. But only the (b) question was addressed by the selected referees [8]. They were asked to review the available evidence of correlation between the reported excess heat and production of fusion products. One third of them stated that the evidence for such correlation was conclusive. That was not sufficient; the attitude of the scientific establishment toward cold fusion research did not change.

5 Conclusion

The CF controversy is unprecedented in terms of its duration, intensity, and caliber of adversaries on both sides of the divide. Huizenga and Fleischmann were indisputable leaders in nuclear science and electrochemistry. CMNS researchers are mostly also Ph.D. level scientists. The same is true for those scientists who believe that the announced discovery of CF was a “scientific fiasco”. We are still waiting for at least one reproducible-on-demand demonstration of a nuclear effect resulting from a chemical (atomic) process. In the case of CF the self-correcting process of scientific development emphasized by Huizenga has not worked. This fiasco seems to be due to the fact that scientists appointed to investigate CF claims did not follow the rules of scientific methodology.

Submitted on January 30, 2012 / Accepted on February 5, 2012

References

- Huizenga J.R. Cold fusion: The scientific fiasco of the century. Oxford University Press, New York, 2nd ed., 1993, pp. 1–10.
- Driscoll J. et al. Issues Related to Reproducibility in a CMNS Experiment. *Journal of Condensed Matter Nuclear Science*, 2011, v. 5, 34–41.
- Kowalski L. Rossi's Reactors – Reality or Fiction? *Progress in Physics*, 2012, v. 1, 33–35. The online version of this article is at: http://www.ptep-online.com/index_files/2012/PP-28-07.PDF
- Jones S.E. et al. Observations of Cold Nuclear Fusion in Condensed Matter. *Nature*, 1989, v. 228, 737–740.
- Beaudette C. Excess Heat: Why Cold Fusion Research Prevailed. Oak Grow Press, LLC, South Bristol, USA, 2000. Also see: http://en.wikipedia.org/wiki/Cold_fusion#Announcement
- Fleischmann M. Private conversation in 2002, after his presentation: “Background to Cold Fusion: The Genesis of a Concept” in: Proceedings of the 10th International Conference on Cold Fusion, World Scientific, 2006.
- ERAB, “Report of the cold fusion panel to the Energy Research Advisory Board”, Department of Energy, DOE/S-0073: Washington, DC, 1989.
- Krivit S. Special online collection, “2004 DOE Review of Cold Fusion” in: <http://www.lenr-canr.org/Collections/DoeReview.htm>
- Storms E. Science of Low Energy Nuclear Reaction: A Comprehensive Compilation of Evidence and Explanations about Cold Fusion. World Scientific Publishing Company, 2007.
- Mosier-Boss P.A. et al. Use of CR-39 in Pd/D Codeposition Experiments: A Response to Kowalski. *European Physical Journal - Applied Physics*, 2008, v. 41, 291–295.
- Hagelstein P.L. et al. New Physical Effects in Metal Deuterides. In: Eleventh International Conference on Condensed Matter Nuclear Science, 2004, Marseille, France.
- Urutskoev L.I. et al. Observation of transformation of chemical elements during an electric discharge. *Annales de la Fondation Louis de Broglie*, 2002, v. 27, 701.
- Karabut A.B. et al. Nuclear product ratio for glow discharge in deuterium. *Physics Letters A*, 1992, v. 170, 265.
- Mizuno T. Nuclear Transmutation: The Reality of Cold Fusion. Infinite Energy Press, 1998.
- Iwamura Y. et al. Elemental Analysis of Pd Complexes: Effects of D₂ gas permeation. *Japanese Journal of Applied Physics*, 2002, v.41, 4642–4648.
- International Conference on Cold Fusion, Cambridge, MA, USA, 2003, (published by World Scientific Co. Pte. Ltd.).
- Proceedings of the 11th International Conference on Cold Fusion, Marseille, France, 2004, (published by World Scientific Co. Pte. Ltd.).
- Proceedings of the 12th International Conference on Cold Fusion, Yokohama, Japan, 2005, (published by World Scientific Co. Pte. Ltd.).

Progress in Physics is an American scientific journal on advanced studies in physics, registered with the Library of Congress (DC, USA): ISSN 1555-5534 (print version) and ISSN 1555-5615 (online version). The journal is peer reviewed and listed in the abstracting and indexing coverage of: Mathematical Reviews of the AMS (USA), DOAJ of Lund University (Sweden), Zentralblatt MATH (Germany), Scientific Commons of the University of St.Gallen (Switzerland), Open-J-Gate (India), Referential Journal of VINITI (Russia), etc. Progress in Physics is an open-access journal published and distributed in accordance with the Budapest Open Initiative: this means that the electronic copies of both full-size version of the journal and the individual papers published therein will always be accessed for reading, download, and copying for any user free of charge. The journal is issued quarterly (four volumes per year).

Electronic version of this journal: <http://www.ptep-online.com>

Editorial board:

Dmitri Rabounski (Editor-in-Chief), Florentin Smarandache, Larissa Borissova

Editorial team:

Gunn Quznetsov, Andreas Ries, Chifu E. Ndikilar, Felix Scholkmann

Postal address:

**Department of Mathematics and Science,
University of New Mexico, 200 College Road, Gallup, NM 87301, USA**

Printed in the United States of America